

Table of Contents

Overview	<u>1</u>
SLC 500 Family	<u>1</u>
MicroLogix 1000 Family	<u>2</u>
New Product Summary	<u>2</u>
SLC 500 System Configuration	<u>3</u>
MicroLogix 1000	<u>4</u>
Types	<u>5</u>
General Specifications	<u>5</u>
Input Specifications	<u>6</u>
DC Input Filter Settings	<u>6</u>
AC Input Filter Settings	<u>6</u>
Output Specifications	<u>7</u>
Relay Contact Rating Table	<u>7</u>
Hand-Held Programmer Specifications	<u>7</u>
SLC 500 Fixed Controller	<u>8</u>
Specifications	<u>9</u>
SLC 500 Modular Controller	<u>11</u>
Communication Options	<u>13</u>
System Protection Options	<u>14</u>
Memory Modules	<u>14</u>
SLC 500 Family Specifications	<u>15</u>
Power Supply Options	<u>16</u>
Chassis Options	<u>17</u>
1746 Discrete I/O Modules	<u>17</u>
1746 Discrete Input Modules	<u>18</u>
1746 Discrete Output Modules	<u>19</u>
Relay Contact Rating Chart	<u>20</u>
1746 Discrete Combination Modules	<u>20</u>
Bulletin 1492 Interface Modules and Cables	<u>21</u>

Speciality I/O Modules	<u>22</u>
1746 I/O Analog Modules	<u>22</u>
Specifications	<u>24</u>
1746-NT4 Thermocouple/mV Module	<u>24</u>
Thermocouple Temperature Ranges	<u>25</u>
DC Millivolt Input Ranges	<u>25</u>
Specifications	<u>26</u>
1746-NR4 RTD/resistance Input Module	<u>27</u>
RTD Temperature Ranges, Resolution, and Repeatability	<u>28</u>
RTD Accuracy and Temperature Drift Specifications	<u>29</u>
Resistance Input Specifications	<u>30</u>
Specifications	<u>30</u>
1746-HSCE High-Speed Counter Module	<u>31</u>
Specifications	<u>31</u>
1746-HSTP1 Stepper Controller Module	<u>32</u>
1746-HS IMCE 110 Servo Positioning Module	<u>33</u>
Remote I/O Modules	<u>34</u>
1747-SN Remote I/O Scanner	<u>34</u>
1747-ASB Remote I/O Adapter Module	<u>35</u>
Specifications for 1747-SN and 1747-ASB	<u>35</u>
Remote I/O Specifications	<u>35</u>
1747-DCM Direct Communication Module	<u>36</u>
Specifications	<u>36</u>
Remote I/O Devices	<u>37</u>
1791 Block I/O	<u>37</u>
1794 Flex I/O	<u>37</u>
2705 RediPANEL Operator Modules	<u>37</u>
2706 Dataliner Message Displays	<u>37</u>
Drives	<u>37</u>
Pyramid Solutions Program (PSP)	<u>38</u>
DeviceNet Network	<u>39</u>
DeviceNet Network Length	<u>39</u>
Remote Communication	<u>40</u>
1747-KE DH-485/RS-232C Interface Module	<u>40</u>
1746-BAS BASIC Module and BASIC Development Software	<u>40</u>
1770-KF3 DH-485 Communication Interface Module	<u>41</u>
Remote Communication Functions	<u>41</u>

Networking Options	42
1784-KR Personal Computer Interface Card	42
Specifications	42
6001-F2E Standard Driver	43
1747-AIC Isolated Link Coupler for DH-485 Connection	43
Programming Options	44
1747-PA2E Advanced Programming Software	44
System Specifications	45
1747-PIC Interface Converter Programming Options	45
Specifications	46
1747-PT1 Hand-Held Terminal and 1747-PTA1E Programming Memory Pak Programming Options	46
SLC 500 A.I. Series Programming Software Programming Options .	47
Operator Interface	48
1747-DTAM-E Data Table Access Module	48
Specifications	49
Bulletin 2707 DTAM Plus Operator Interface	49
Bulletin 2707 DTAM Micro	49
1784-TM6 I/O Monitor	50
2711 PanelView Operator Terminals	50
Allen-Bradley Support	51
User Documentation on CD-ROM	51
Configuring an SLC 500 System	51
SLC 500 Chassis Configuration Instructions	52
Fixed I/O Chassis Module Compatibility	54
Tabular Method	54
Fixed I/O Chassis – Module Compatibility Table	55
Charting Method	56
Instruction Set	57
Fixed Wiring Diagrams	58
Approximate Chassis Dimensions	60
Available Cables	63

Overview

Both the SLC 500™ family and the MicroLogix™ family give you power and flexibility for a complete control solution. The powerful processor instruction sets, advanced programming tools, and expanded product capabilities give you all of the right reasons to choose these products for your next control application.

SLC 500 Family

The SLC 500 family is a growing family of small programmable controllers built around two hardware options: a fixed controller or a modular controller. The fixed controller provides the power supply, inputs and outputs, and processor all in one unit. The fixed controller also offers a 2-slot expansion chassis for increased flexibility.

The modular controller offers you additional flexibility in system configuration, more processing power, and I/O capacity. This allows you to create a controller system specifically designed for your application. The programming tools and most I/O modules are compatible between the two hardware options, so you can cost effectively solve a broad range of applications.

In addition to configuration flexibility, SLC 500 programmable controllers communicate across an embedded DH-485 network allowing program support and monitoring. The SLC 5/03™ processor, Catalog Number 1747-L532 provides up to 960 I/O points, online programming, and a keyswitch for selecting 1 of 3 modes of operation (Run, Program and Remote). Also included in the SLC 5/03 processor is an RS-232 channel that supports asynchronous serial data communication between terminal devices. The SLC 5/04™ processors, Catalog Numbers 1747-L541, 1747-L542, and 1747-L543, provide the same features as the SLC 5/03 with additional functions. For example, the SLC 5/04 processor provides an on-board math co-processor for faster execution times of math instructions. It also has a built-in Data Highway Plus™ (DH+™) port for direct connection to the DH+ network. Direct DH+ connection allows the SLC 5/04 to communicate with PLC-5® processors on the DH+ network without the need for additional network interface hardware. For implementation of a distributed I/O system, any SLC 500 programmable controller used with the Direct Communication Module (DCM), the Scanner Module (SN), or the DeviceNet™ Scanner Module (SDN) integrates into the Allen-Bradley 1771 Remote I/O network and DeviceNet network respectively.

The SLC 500 family offers a variety of discrete I/O modules that enable you to cost-effectively configure your control system. The addition of 32 point I/O modules reduces panel space requirements. All of the discrete and specialty I/O modules are UL and CSA certified for industrial applications. The majority are approved for Class I, Division 2 hazardous environments. Most of the SLC 500 modular components are CE compliant. Refer to the product specifications for specific agency certifications.

MicroLogix 1000 Family

The MicroLogix 1000 family of programmable controllers is designed to meet your control needs in a variety of applications requiring under 32 I/O. Positioned as part of the SLC 500 family, the MicroLogix 1000 family offers you a small, low-cost programmable controller with a powerful instruction set and fast execution speed for high throughput. Like the SLC 500 family, the MicroLogix controllers are programmed using familiar ladder logic.

The MicroLogix 1000 controllers can be programmed using MicroLogix 1000 Programming Software (MPS) A.I. Series™, SLC 500 A.I. Series programming software, or the MicroLogix 1000 Hand-Held Programmer (HHP).

New Product Summary

The following table shows the page references for the new SLC 500 MicroLogix 1000 products and other related product lines:

Catalog Number	Description	Page Number
9323-MX300EN	MicroLogix 1000 Programming Software (MPS) A.I. Series	4
9323-S5300D	SLC 500 A.I. Series programming software	4
1761-L32AAA	MicroLogix 1000 Programmable Controller	5
1747-L542, -L543	SLC 5/04 Processors	11
1746-FIO4I, -FIO4V	Analog I/O Modules	22
Not Applicable ^①	DeviceNet	39

^① DeviceNet is made up of various devices that have their own catalog numbers.

SLC 500 System Configuration

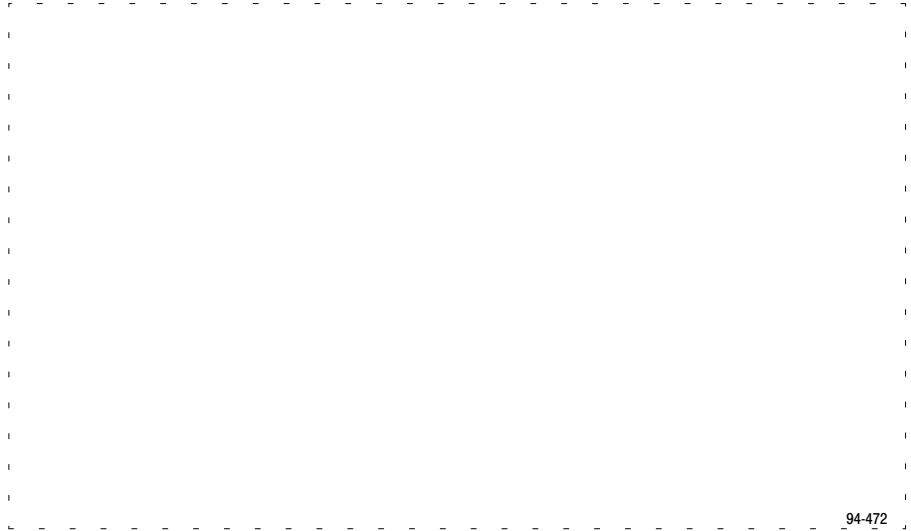

MicroLogix 1000

The MicroLogix 1000 Programmable Controller supplements the SLC 500 controller family by providing a small, low cost version that offers outstanding performance, superior reliability, and high quality. This product family offers you several types of controllers, development tools, and operator interfaces to meet your control needs for a variety of applications.

The MicroLogix 1000 controllers can be programmed using MicroLogix 1000 Programming Software (MPS) A.I. Series, SLC 500 A.I. Series programming software, or the MicroLogix 1000 Hand-Held Programmer (HHP).

For dimensions of the MicroLogix 1000 units, refer to page 60.

Features	Benefits
16 or 32 I/O versions with 4 different electrical configurations	Provides flexibility to meet the needs of almost any application.
1K user memory capacity	Provides enough memory capability to meet most application needs.
Over 65 programming instructions	Provides powerful instruction set to develop the right program for the application.
Built-in EEPROM memory	Retains program and data after a power failure. No need for battery backup or additional memory module.
RS-232 communication channel	Provides connection to a personal computer, operator interface, and modem.
Compact size	Enables the unit to fit in tight spaces.

Types

Catalog Number	Description
1761-L16AWA	10 pt. AC input, 6 pt. relay output, AC power supply controller
1761-L32AWA	20 pt. AC input, 12 pt. relay output, AC power supply controller
1761-L16BWA	10 pt. DC input, 6 pt. relay output, AC power supply controller
1761-L32BWA	20 pt. DC input, 12 pt. relay output, AC power supply controller
1761-L16BWB	10 pt. DC input, 6 pt. relay output, DC power supply controller
1761-L32BWB	20 pt. DC input, 12 pt. relay output, DC power supply controller
1761-L16BBB	10 pt. DC input, 4 pt. FET and 2 pt. relay outputs, DC power supply controller
1761-L32BBB	20 pt. DC input, 10 pt. FET and 2 pt. relay outputs, DC power supply controller
1761-L32AAA	20 pt. AC input, 10 pt. triac and 2 pt. relay outputs, AC power supply controller

General Specifications

Description	Specification: 1761-L									
	16AWA	16BWA	32AWA	32BWA	32AAA	16BBB	16BWB	32BBB	32BWB	
Memory Size and Type	1K EEPROM (approximately 737 instruction words: 437 data words)									
Power Supply Voltage	85–264V ac					20.4–26.4V dc				
Power Supply Usage	120V ac	12 VA	19 VA	16 VA	24 VA	16 VA	Not Applicable			
	240V ac	18 VA	26 VA	22 VA	30 VA	22 VA				
	24V dc	Not Applicable					5 VA	5 VA	7 VA	7 VA
Power Supply Maximum Inrush Current	20A					50A				
24V dc Sensor Power (V dc at mA)	Not Applicable	200 mA	Not Applicable	200 mA	Not Applicable					
Max Capacitive Load (User 24 V dc)	Not Applicable	200 μ F	Not Applicable	200 μ F						
Power Cycles	50,000 minimum									
Operating Temperature	0° C to 55° C (32° F to 131° F)									
Storage Temperature	–40° C to 85° C (–40° F to 185° F)									
Operating Humidity	5 to 95% noncondensing									
Vibration	Operating: 5 Hz to 2k Hz, 0.381 mm (0.015 in.) peak to peak/2.5G panel mounted, ^① 1hr per axis									
	Non-operating: 5 Hz to 2k Hz, 0.762 mm (0.030 in.) peak to peak/5G, 1hr per axis									
Shock	Operating: 10G peak acceleration (7.5g DIN rail mounted) ^② (11±1 ms duration) 3 times each direction, each axis									
	Non-operating: 20G peak acceleration (11±1 ms duration), 3 times each direction, each axis									
Certification (when product or packaging is marked)	<ul style="list-style-type: none"> • CSA certified • UL listed • CE marked for all applicable directives 									
Terminal Screw Torque	0.9 N-m maximum.C (8.0 in.-lbs)									
Electrostatic Discharge	IEC801-2 @ 8K V									
Radiated Susceptibility	IEC801-3 @ 10 V/m, 27 MHz - 1000 MHz									
Fast Transient	IEC801-4 @ 2K V Power Supply, 1K V I/O									
Isolation	1500V ac									

^① DIN rail mounted controller is 1G.

^② Relays are derated an additional 2.5G on 32 pt. controllers.

Input Specifications

Description	Specification	
Type	100-120V ac	24V dc
Voltage Range	79 to 132V ac 47 to 63 Hz	15 to 30V dc
On Voltage	79V ac min. 132V ac max.	15V dc min. 24V dc nominal 26.4V dc max. @ 55° C (131° F) 30.0V dc max. @ 30° C (86° F)
Off Voltage	20V ac	5V dc
On Current	5.0 mA min. @ 79V ac 47 Hz 12.0 mA nominal @ 120V ac 60 Hz 16.0 mA max. @ 132V ac 63 Hz	2.5 mA min. @ 15V dc 8.0 mA nominal @ 24V dc 12.0 mA max. @ 30V dc
Off Current	2.5 mA max.	1.5 mA max.
Nominal Impedance	12K ohms @ 50 Hz 10K ohms @ 60 Hz	3K ohms
Inrush Maximum	250 mA max. ^①	Not Applicable

^① To reduce the inrush maximum to 35 mA, apply a 6.8K ohm, 5w resistor in series with the input. The on-state voltage increases to 92V ac as a result.

DC Input Filter Settings

DC input filters are adjustable as shown below.

Nominal Filter Setting (ms)	Minimum On Delay (ms)	Maximum On Delay (ms)	Minimum Off Delay (ms)	Maximum Off Delay (ms)
0.075 ^①	0.009	0.075	0.009	0.075
0.10 ^①	0.040	0.100	0.040	0.100
0.25 ^①	0.147	0.250	0.147	0.250
0.50	0.014	0.500	0.014	0.500
1	0.091	1.000	0.091	1.000
2	0.618	2.000	0.618	2.000
4	2.441	4.000	2.441	4.000
8	6.256	8.000	6.256	8.000
16	13.37	16.00	13.37	16.00

^① Inputs 0 to 3 only.

AC Input Filter Settings

Nominal Filter Setting (ms) ^①	Minimum ON Delay (ms)	Maximum ON Delay (ms)	Minimum OFF Delay (ms)	Maximum OFF Delay (ms)
8.0	2.0	20.0	10.0	20.0

^① There is only one filter setting available for the AC inputs.

Output Specifications

Description	Specification		
	Relay	MOSFET	Triac
Type	Relay	MOSFET	Triac
Voltage	5 to 264V ac 5 to 125V dc	20.4 to 26.4V dc	85 to 264V ac
Maximum Load Current	Refer to the Relay Contact Rating Table.	1.0A per point @ 55° C (131° F) 1.5A per point @ 30° C (86° F)	0.5A per point
Minimum Load Current	10.0 mA	1 mA	10.0 mA
Current per Controller	1440 VA	3A for L16BBB 6A for L32BBB	1440 VA
Current per Common	8.0A	3A for L16BBB 6A for L32BBB	2.5A
Maximum Off State Leakage Current	0 mA	1 mA	2 mA @ 132V ac 4.5 mA @ 264V ac
Off to On Response	10 ms max.	0.1 ms	8.8 ms @ 60 Hz 10.6 ms @ 50 Hz
On to Off Response	10 ms max.	1 ms	11.0 ms
Surge Current per Point	Not Applicable	3A for 10 ms ^①	10A for 25 ms ^①

^① Repeatability is once every 2 seconds at 55° C (131° F).

Relay Contact Rating Table

Maximum Volts	Amperes		Amperes Continuous	Volt-Amperes	
	Make	Break		Make	Break
240V ac	7.5A	0.75A	2.5A	1800 VA	180 VA
120V ac	15A	1.5A			
125V dc	0.22A ^①		1.0A	28 VA	
24V dc	1.2A ^①		2.0A	28 VA	

^① For DC voltage applications, the make/break ampere rating for relay contacts can be determined by dividing 28 VA by the applied DC voltage. For example, $28 \text{ VA} \div 48 \text{ V dc} = 0.58 \text{ A}$. For DC voltage applications less than 48V, the make/break ratings for relay contacts cannot exceed 2A. For DC voltage applications greater than 48V, the make/break ratings for relay contacts cannot exceed 1A.

Hand-Held Programmer Specifications

Description	Specification: 1761-HHP-B30
Operating Power	83 mA @ 24V dc
Operating Temperature	0° C to 50° C (32° F to 122° F)
Storage Temperature	-20° C to 60° C (-4° F to 140° F)
Operating Humidity	5 to 95% noncondensing
Certification (when product or packaging is marked)	<ul style="list-style-type: none"> • CSA certified • UL listed • CE marked for all applicable directives
Display Type	2 x 16 LCD
Keypad	30 Rubber/carbon Based Keys

SLC 500 Fixed Controller

The SLC 500 Fixed Controller, which contains a processor, power supply, and I/O in a single package, offers a variety of low cost options with up to 104 predefined Input/Output (I/O) points. This controller also offers enhanced networking capabilities. For more information concerning I/O module compatibility options, refer to page 55.

Features

20, 30, or 40 I/O versions with 24 different I/O configurations.

Optional 2-slot expansion chassis

200 mA of 24V dc user power

Optional EEPROM or UV PROM backup memory

Selectable 8k Hz counter or normal DC input

Benefits

Provides a wide variety of fixed I/O configurations to meet your application requirements.

Allows for 64 additional I/O points or utilization of a wide range of specialty I/O modules.

Eliminates the need for an external power supply when using DC sensors.

Provides non-volatile storage of your ladder program.

Eliminates the added cost of a separate high speed counter module.

Specifications

The following table provides general specifications for the fixed controller.

Description	Specification
Program Memory	1K Instruction
Standard RAM	Capacitor – 2 weeks ^① Lithium Battery – 5 years ^②
Memory Back-up Options	EEPROM or UVPROM
Typical Scan Time	8 ms/K
Hold-up Time (Load Dependent)	20 ms to 700 ms
LED Indicators	RUN, CPU FAULT, FORCED I/O, BATTERY LOW
Programming	Advanced Programming Software, SLC 500 A.I. Series programming software, or the Hand-Held Terminal
Power Requirement (max.)	50 VA
Noise Immunity	NEMA Standard ICS 2-230
Fuse Protection 120/240V ac 24V dc	1.25A 1.6A
Vibration (operating)	Displacement: .015 inch, peak-to-peak @ 5 - 57 Hz
	Acceleration: 2.5Gs at 57 – 2000 Hz
	Duration: 1 hr per axis (x,y,z)
Shock (operating)	30Gs
Environmental conditions Operating temperature Storage temperature Humidity rating	0° C to +60° C (+32° F to +140° F) –40° C to +85° C (–40° F to +185° F) 5 to 95% (non-condensing)
Wire Size	24 AWG to 14 (max.)
Communication	DH-485 receive
Certification (when product or packaging is marked)	<ul style="list-style-type: none"> • CSA certified • UL listed

^① 1747-L511 only – The capacitor back-up is rated at 35° C (95° F).

^② Lithium battery is optional for the L511; standard for the L514.

The following tables provide configuration options for 20, 30, or 40 I/O point units. To aid you in configuring your system with additional modules when using the optional 2-slot expansion chassis, refer to the Fixed Expansion Chassis Compatibility table on page 55.

Catalog Number	I/O Configuration	Input	Output	Input Type	Output Type	Power Supply	High-Speed Counter	User Power		
1747-L20A	20	12	8	120V ac	Relay	120/240V ac	No	-		
1747-L20B					Triac	120/240V ac	No	-		
1747-L20C				24V dc Sinking	Relay	120/240V ac	Yes	24V-200 mA		
1747-L20D					Triac	120/240V ac	Yes	24V-200 mA		
1747-L20E					Transistor Source	120/240V ac	Yes	24V-200 mA		
1747-L20F					Relay	24V dc	Yes	-		
1747-L20G				24V dc Sourcing	Transistor Source	24V dc	Yes	-		
1747-L20L					Transistor Sink	120/240V ac	Yes	24V-200 mA		
1747-L20N				240V ac	Transistor Sink	24V dc	Yes	-		
1747-L20P					Triac	120/240V ac	No	-		
1747-L20R				240V ac	Relay	120/240V ac	No	-		
1747-L30A					30	18	120V ac	Relay	120/240V ac	No
1747-L30B				Triac				120/240V ac	No	-
1747-L30C				24V dc Sinking			Relay	120/240V ac	Yes	24V-200 mA
1747-L30D	Triac	120/240V ac	Yes				24V-200 mA			
1747-L30L	24V dc Sourcing	Transistor Sink	120/240V ac	Yes			24V-200 mA			
1747-L30P	240V ac	Triac	120/240V ac	No			-			
1747-L40A	40	24	16	120V ac	Relay	120/240V ac	No	-		
1747-L40B					Triac	120/240V ac	No	-		
1747-L40C				24V dc Sinking	Relay	120/240V ac	Yes	24V-200 mA		
1747-L40E					Transistor Source	120/240V ac	Yes	24V-200 mA		
1747-L40F				24V dc Sourcing	Relay	24V dc	Yes	-		
1747-L40L					Transistor Sink	120/240V ac	Yes	24V-200 mA		
1747-L40P				240V ac	Triac	120/240V ac	No	-		
1746-A2				2-Slot Expansion Chassis (can only be used with the fixed hardware style configurations)						

SLC 500 Modular Controller

The SLC 500 Modular Controller offers additional flexibility in system configuration, more processing power, and I/O capacity. By selecting the appropriate modular chassis, power supply, processor, and discrete or specialty I/O modules, you can create a controller system specifically designed for your application. Processor options include:

- SLC 5/01™ – 1K or 4K instructions processor (Catalog Number 1747-L511 or 1747-L514) with an instruction set identical to the SLC 500 fixed processor.
- SLC 5/02 – 4K processor (Catalog Number 1747-L524) with an enhanced instruction set.
- SLC 5/03 – 12K words and 4K additional data storage (Catalog Number 1747-L532) with flexible communications.
- SLC 5/04 – 12K, 28K, or 60K words and 4K of additional data words (Catalog Numbers 1747-L541, 1747-L542, or 1747-L543) with DH+ communications and speed exceeding the SLC 5/03 processor. Also, provides RS-232 or DH-485 selectability.

The instruction set is available on page 57 for your reference.

91-071-4

Features	Benefits
Four central processing units	Supports a variety of I/O requirements and functionality.
Four different chassis sizes (4, 7, 10, and 13)	Provides I/O mounting flexibility and expansion options.
Variety of 1746 I/O modules	Provides over 48 different modules to meet your application needs.
Four power supplies	Supports AC and DC power, providing four different sizes.
Variety of communication options	Support of DH-485, RS-232, and DH+ communication.
Certification	UL listed, CSA approved Class I, Division 2 hazardous environment (exceptions indicated). CE marked for all applicable directives (exceptions indicated).

The following table summarizes the detailed specifications for the SLC 500 processor family:

Specification	SLC 5/01 (1747-L511, -L514)	SLC 5/02 (1747-L524)	SLC 5/03 (1747-L532)	SLC 5/04		
				1747-L541	1747-L542	1747-L543
Program Memory	1K or 4K Instructions	4K Instructions	12K Words	12K Words	28K Words	60K Words
Additional Data Storage	0	0	up to 4K Words	up to 4K Words	up to 4K Words	up to 4K Words
Max. Local I/O Capacity	256 Discrete	480 Discrete	960 Discrete	960 Discrete	960 Discrete	960 Discrete
Remote I/O	NA	Maximum number dependent on system power supply loading and program memory size. (4096 inputs and 4096 outputs maximum)				
Max. Local Chassis/Slots	3/30	3/30	3/30	3/30	3/30	3/30
Programming	APS, SLC 500 A.I. Series, and HHT	APS, SLC 500 A.I. Series, and HHT	APS and SLC 500 A.I. Series	APS and SLC 500 A.I. Series	APS and SLC 500 A.I. Series	APS and SLC 500 A.I. Series
Programming Instructions	52	71	99	99	99	99
Typical Scan Time ^①	8 ms/K	4.8 ms/K	1 ms/K	0.9 ms/K	0.9 ms/K	0.9 ms/K
Bit Execution (XIC)	4 μs	2.4 μs	0.44 μs	0.37 μs	0.37 μs	0.37 μs

^① The scan times are typical for a 1K ladder logic program consisting of simple ladder logic and communication servicing. Actual scan times depend on your program size, instructions used, and the communication protocol.

The following table summarizes the general specifications for the SLC 500 modular processors. Additional specifications are located on page 15.

Description	Specification
Power Supply Loading at 5V dc	350 mA for SLC 5/01, and SLC 5/02 processor
	500 mA for the SLC 5/03 processor
	1.0A for the SLC 5/04 processor
Power Supply Loading at 24V dc	105 mA for SLC 5/01, and SLC 5/02 processor
	175 mA for the SLC 5/03 processor
	200 mA for the SLC 5/04 processor
Program Scan Hold-up Time after Loss of Power	20 ms to 3s (dependent on power supply loading)
Clock/Calendar Accuracy (applicable only to SLC 5/03 and SLC 5/04 processors)	+ or – 54 sec/month @ 25° C (77° F) + or – 81 sec/month @ 60° C (140° F)
Noise Immunity	NEMA Standard ICS 2-230
Vibration	Displacement: 0.015 inch, peak-to-peak at 5–57 Hz
	Acceleration: 2.5Gs at 57–2000 Hz
Shock (operating)	30Gs
Ambient Temperature Rating	Operating: 0 to + 60° C (32° F to 140° F) Storage: –40° C to 85° C (–40° F to 185° F)
Humidity	5 to 95% without condensation
Certification (when product or packaging is marked)	<ul style="list-style-type: none"> • CSA certified • UL listed • Class 1, Groups A, B, C or D, Division 2 • CE marked for all applicable directives

Communication Options

The following table summarizes the communication options for the SLC 500 processor family.

Communication	Receive	Receive or Initiate
DH-485	SLC 5/01	SLC 5/02, SLC 5/03, SLC 5/04 ^①
RS-232 (DF1 Full-Duplex, DF1 Half-Duplex Master/Slave, DH-485, or ASCII)	SLC 5/01 ^①	SLC 5/02 ^① , SLC 5/03 ^② , SLC 5/04 ^②
Data Highway Plus	SLC 5/01 ^{③④}	SLC 5/02 ^{③④} , SLC 5/03 ^③ , SLC 5/04

^① A 1747-PIC is required when connecting to the DH-485 channel.

^② You can connect channel 0 of the SLC 5/03 or SLC 5/04 processors to devices that support DH485 using the 1746-CP3 cable in a point-to-point connection. You can also connect channel 0 of the SLC 5/03 or SLC 5/04 processors to the 1746-PIC to make a connection to devices (SLC 5/01, SLC 5/02, SLC 5/03, and AIC link coupler) that support DH485.

^③ A 1785-KA5 is required.

^④ Receive is only through the 1785-KA5.

System Protection Options

The SLC 500 family of processors offer a number of hardware and software security features designed to help you protect your system from unauthorized changes to program or data files. The different types of protection are:

Types of Protection	SLC 5/01	SLC 5/02	SLC 5/03 and SLC 5/04
Password	•	•	•
Future Access (OEM Lock)	•	•	•
Program Owner	•	•	•
Program Files	NA	NA	•
Data Table Files	•	•	•
Memory Module Data File Overwrite	NA	NA	•
Memory Module Program Compare	NA	NA	•
Memory Module Write Protection	NA	NA	•
Force Protection	NA	NA	•
Keyswitch	NA	NA	•
Communication Channel Protection	NA	NA	•

NA (Not Applicable)

Memory Modules

The following table summarizes the available memory back up options for the SLC 500 processors. EEPROM and UVPRM memory modules provide non-volatile memory back-up. Flash EPROMs (Flash Erasable Programmable Read Only Memory) combine the versatility of EEPROMs with the security of UVPRMs.

Memory Back Up Option	SLC 5/01 (1747-L511, -L514)	SLC 5/02 (1747-L524)	SLC 5/03 (1747-L532)	SLC 5/04		
				1747-L541	1747-L542	1747-L543
EEPROM	1747-M1, 1747-M2	1747-M2	NA	NA	NA	NA
UVPRM	1747-M3, 1747-M4	1747-M4	NA	NA	NA	NA
Flash	NA	NA	1747-M11 1747-M12 (OS302 only)	1747-M11 1747-M12 (OS401 only)	1747-M11 1747-M12 (OS401 only)	1747-M11 1747-M12 (OS401 only)

NA (Not Applicable)

SLC 500 Family Specifications

The following specifications apply to all SLC 500 modular components.

Description	Specification	Industry Standard
Temperature	Operating: 0° C to +60° C (32° F to 140° F)	Not Applicable
	Storage: -40° C to +85° C (-40° F to 185° F)	Not Applicable
Humidity	5 to 95% without condensation	Not Applicable
Vibration	Operating: 1.0G @ 5 - 2000 Hz	Not Applicable
	Non-operating: 2.5Gs @ 5 - 2000 Hz	Not Applicable
Shock	Operating: (all modules except relay contact) 30.0Gs (3 pulses, 11 ms)	Not Applicable
	Operating: (relay contact modules - OW, IO combo) 10.0Gs (3 pulses, 11 ms)	Not Applicable
	Non-operating: 50.0Gs (3 pulses, 11 ms)	Not Applicable
Free Fall (drop test)	Portable, 2.268 kg (5 lbs) or less @ 0.762 m (30 in.) (six drops)	Not Applicable
	Portable, 2.268 kg (5 lbs) or more @ 0.1016 m (4 in.) (three flat drops)	Not Applicable
Electromagnetic Compatibility	Showering Arc: 1.5 KV	NEMA ICS 2-230/NEMA ICS 3-304
	Surge Withstand Capability: 3 KV	IEEE Std. 472-1974/ANSI C37.90/90A-1974
	Fast Transient Burst (impulse): 2KV for 1746 power supplies, 1KV for 1746 I/O and communication lines over 10m (32.84 ft), 5 ns rise time	Internal Allen-Bradley standard ^①
	Electrostatic Discharge (ESD): 15 KV, 100 pF/1.5 Kohm model	Internal Allen-Bradley standard ^①
	Radiated Electromagnetic Susceptibility: 5w walkie-talkie @ 464.5 MHz and 153.05 MHz	Internal Allen-Bradley standard ^①
Safety	Dielectric Withstand: 1500V ac	UL 508, CSA C22.2 No. 142
	Isolation between Communication Circuits: 500V dc	Not Applicable
	Isolation between Backplane and I/Os: 1500V ac	Not Applicable
	Flammability and Electrical Ignition: UL94V-0	Not Applicable
Certification (when product or packaging is marked)	<ul style="list-style-type: none"> • CSA certified • UL listed • Class 1, Groups A, B, C or D, Division 2 • CE marked for all applicable directives 	Not Applicable

^① Internal Allen-Bradley standards are based on Allen-Bradley's extensive experience in industrial controls. It is also based partly on industry and/or military specifications.

Power Supply Options

Allen-Bradley offers 4 different power supplies, three AC and one 24V dc. The AC supplies can be configured to operate using 120 or 240V ac.

Description	1746-P1	1746-P2	1746-P3	1746-P4
Line Voltage	85–132/170–265V ac 47–63 Hz	85–132/170–265V ac 47–63 Hz	19.2–28.8V dc	85–132/170–265V ac 47–63 Hz
Typical Line Power Requirement	135 VA	180 VA	90 VA	240 VA
Maximum Inrush Current	20A	20A	20A	45A
Internal Current Capacity	2A at 5V dc 0.46A at 24V dc	5A at 5V dc 0.96A at 24V dc	3.6A at 5V dc 0.87A at 24V dc	10.0A at 5V dc 2.88A at 24V dc ^②
Fuse Protection ^①	1746-F1 or equivalent: 250V-3A Fuse Nagasawa ULCS-61ML-3 or BUSSMANN AGC 3	1746-F2 or equivalent: 250V-3A Fuse SANO SOC SD4 or BUSSMANN AGC 3	1746-F3 or equivalent: 125V-5A Fuse Nagasawa ULCS-61ML-5 or BUSSMAN AGC 5	Non-replaceable fuse is soldered in place.
24V dc User Power Current Capacity	200 mA	200 mA	Not Applicable	1A ^②
24V dc User Power Voltage Range	18–30V dc	18–30V dc	Not Applicable	20.4–27.6V dc
Ambient Operating Temperature Rating	0° C to 60° C (32° F to 140° F) (Current capacity derated 5% above 55° C)			0° C to 60° C (32° F to 140° F) no derating
Storage Temperature	–40° C to 85° C (–40° F to 185° F)			
Humidity Rating	5–95% (non-condensing)			
Wiring	two 14 AWG wires per terminal (maximum)			
Certification (when product or packaging is marked)	<ul style="list-style-type: none"> • CSA certified • UL listed • CE marked for all applicable directives 			
Hazardous Environment Certification	Class I Division 2 ^③			

^① Power supply fuse is intended to guard against fire hazard due to short circuit conditions and may not protect the supply from damage under overload conditions.

^② The combination of all output power (5 volt backplane, 24 volt backplane, and 24 volt user source) cannot exceed 70 Watts.

^③ The 1746-P4 power supply is certified for Class I Division 2 by CSA only.

Chassis Options

The chassis houses the processor and the I/O modules. There are four sizes of chassis that you can choose: 4-slot, 7-slot, 10-slot, and 13-slot. The power supply mounts on the left side of the chassis. All components easily slide into the chassis along guides formed in the chassis. No tools are required to insert or remove the processor or I/O modules.

Chassis can also be connected together to form a system (3 chassis maximum) by using one of two chassis interconnect cables. For chassis dimensions, refer to page 61.

Catalog Number	Description
1746-A4	4-Slot Chassis
1746-A7	7-Slot Chassis
1746-A10	10-Slot Chassis
1746-A13	13-Slot Chassis
1746-C7	152.4 mm (6 in.) Chassis Interconnect Cable – This ribbon cable is used when linking modular hardware style chassis up to 152.4 mm (6 in.) apart in an enclosure.
1746-C9	914.4 mm (36 in.) Chassis Interconnect Cable – This cable is used when linking modular hardware style chassis from 152.4 mm (6 in.) up to 914.4 mm (36 in.) apart in an enclosure.

1746 Discrete I/O Modules

The 1746 I/O platform is a modular hardware design that uses a cost and space effective means to add I/O modules to your control system. I/O modules are available in a variety of densities including 4, 8, 16, and 32 point and can interface to AC, DC, and TTL voltage levels.

Features

High density 32-point and combination modules

High current relay contact and solid-state output modules

Removable terminal blocks on 16-point modules

Industrial design

Benefits

Reduces rack size and panel space requirements.

Eliminates the need for interfacing relays for switching loads.

Provides ease of wiring and module replacement.

Provides input filtering and optical isolation for exceptional reliability in industrial applications.

1746 Discrete Input Modules

Voltage Category	Operating Voltage (Volts)	Number of Inputs	Points Per Common	Catalog Number	Backplane Current Draw (Amps)		Signal Delay (ms. max)	Off-State Current (max.)	
					5 V	24 V			
100/120V ac	85-132	4	4	1746-IA4	0.035	0	on=35 off=45	2 mA	
	85-132	8	8	1746-IA8	0.050	0	on=35 off=45	2 mA	
	85-132	16	16	1746-IA16 (RTB)	0.085	0	on=35 off=45	2 mA	
200/240V ac	170-265	4	4	1746-IM4	0.035	0	on=35 off=45	2 mA	
	170-265	8	8	1746-IM8	0.050	0	on=35 off=45	2 mA	
	170-265	16	16	1746-IM16 (RTB)	0.085	0	on=35 off=45	2 mA	
24V ac/DC	10-30 DC sink 10-30 AC	16	16	1746-IN16 (RTB)	0.085	0	on=15 DC off=15 DC on=25 AC off=25 AC	1 mA AC & DC	
24V dc	10-30 sink	8	8	1746-IB8	0.050	0	on=8 off=8	1 mA	
	10-30 sink	16	16	1746-IB16 (RTB)	0.085	0	on=8 off=8	1 mA	
	15-30 at 50° C (122° F) 15-26.4 at 60° C (140° F) sink	32	8	1746-IB32^{①②}	0.106	0	on=3 off=3	1.6 mA	
	10-30 sink	16 (Fast Response)	16	1746-ITB16 (RTB)	0.085	0	on=0.3 off=0.5	1.5 mA	
	10-30 source	8	8	1746-IV8	0.050	0	on=8 off=8	1 mA	
	10-30 source	16	16	1746-IV16 (RTB)	0.085	0	on=8 off=8	1 mA	
	10-30 source	16 (Fast Response)	16	1746-ITV16 (RTB)	0.085	0	on=0.3 off=0.5	1.5 mA	
	15-30 at 50° C (122° F) 15-26.4 at 60° C (140° F) source	32	8	1746-IV32^{①②}	0.106	0	on=3 off=3	1.6 mA	
48 V dc	30-60 at 55° C (122° F) 30-55 at 60° C (140° F) sink	16	16	1746-IC16^③ (RTB)	0.085	0	on=4 off=4	1.5 mA	
5	TTL	4.5-5.5 source	16	16	1746-IG16^④ (RTB)	0.140	0	on=0.25 off=0.50	4.1 mA

① Certified for Class I, Division 2 hazardous location by CSA only.

② Ribbon cable connector. User must construct cable or purchase 1492-series pre-wired cable.

③ Use ID code 0509 when configuring your system with your programming software or the Hand-Held Terminal.

④ This product does not have CE certification.

RTB = Removable Terminal Block.

1746 Discrete Output Modules

Voltage Category	Operating Voltage (Volts)	Number of Outputs	Points Per Common	Catalog Number	Backplane Current Draw (Amps)		Signal Delay (ms. max)	Off State Leakage (max.)	Load Current at 5V dc (min.)	Continuous Current per Point (max.)	Continuous Current per Module (max.)
					5 V	24 V					
120/ 240V ac	85-265	8	4	1746-OA8	0.185	0	on=1.0 off=11.0	2 mA	10 mA	1A at 30° C (86° F) 0.50A at 60° C (140° F)	8A at 30° C (86° F) 4A at 60° C (140° F)
	85-265	16	8	1746-OA16 (RTB)	0.370	0	on=1.0 off=11.0	2 mA	10 mA	0.50A at 30° C (86° F) 0.25A at 60° C (140° F)	8A at 30° C (86° F) 4A at 60° C (140° F)
	85-265	12	6	1746-OAP12 ^{①②} (RTB)	0.370	0	on=1.0 off=11.0	2 mA	10 mA	2.0A at 30°C (86° F) 1.25A at 55°C (122° F) 1.0A at 60°C (140° F)	9.0A at 30°C (86° F) 6.0A at 60°C (140° F)
24V dc	10-50 source	8	8	1746-OB8	0.135	0	on=0.10 off=1.0	1 mA	1 mA	1A at 30° C (86° F) 0.50A at 60° C (140° F)	8A at 30° C (86° F) 4A at 60° C (140° F)
	10-50 source	16	16	1746-OB16 (RTB)	0.280	0	on=0.10 off=1.0	1 mA	1 mA	0.50A at 30° C (86° F) 0.25A at 60° C (140° F)	8A at 30° C (86° F) 4A at 60° C (140° F)
	20.4-26.4 source	8	4	1746-OBP8 ^② (RTB)	0.135	0	on=1.0 off=2.0	1 mA	1 mA	2.0A at 60° C (140° F)	8.0A at 60° C (140° F)
	20.4-26.4 source	16	16	1746-OBP16 ^{①③} (RTB)	0.250	0	on=0.10 off=1.0	1 mA	1 mA	1.5A at 30° C (86° F) 1.0A at 60° C (140° F)	6.4A at 0° to 60° C (140° F)
	5-50 source	32	16	1746-OB32 ^{③④}	0.452	0	on=0.10 off=1.0	1 mA	1 mA	0.1A at 60° C (140° F)	3.2A at 60° C (140° F)
	10-50 sink	8	8	1746-OV8	0.135	0	on=0.10 off=1.0	1 mA	1 mA	1A at 30° C (86° F) 0.50A at 60° C (140° F)	8A at 30° C (86° F) 4A at 60° C (140° F)
	10-50 sink	16	16	1746-OV16 (RTB)	0.270	0	on=0.10 off=1.0	1 mA	1 mA	0.50A at 30° C (86° F) 0.25A at 60° C (140° F)	8A at 30° C (86° F) 4A at 60° C (140° F)
	20.4-26.4 sink	16	16	1746-OVP16 ^{①③}	0.250	0	on=0.10 ms off=1.0 ms	1 mA	1 mA	1.5A at 30° C (86° F) 1.0A at 60° C (140° F)	6.4A at 0° to 60° C (140° F)
	5-50 sink	32	16	1746-OV32 ^{③④}	0.452	0	on=0.10 off=1.0	1 mA	1 mA	0.1A at 60° C (140° F)	3.2A at 60° C (140° F)
5 TTL	4.5-5.5 sink	16	16	1746-OG16 ^⑤ (RTB)	0.180	0	on=0.25 off=0.50	0.10 mA	0.15 mA	0.024A	Not applicable

Continued on following page

Voltage Category	Operating Voltage (Volts)	Number of Outputs	Points Per Common	Catalog Number	Backplane Current Draw (Amps)		Signal Delay (ms. max)	Off State Leakage (max.)	Load Current at 5V dc (min.)	Continuous Current per Point (max.)	Continuous Current per Module (max.)
					5 V	24 V					
V ac/V dc Relay	5-265V ac 5-125V dc	4	4	1746-OW4 ^①	0.045	0.045	on=10.0 off=10.0	0 mA	10 mA	see relay chart	8.0A 8.0A/common ^⑥
	5-265V ac 5-125V dc	8	4	1746-OW8 ^②	0.085	0.090	on=10.0 off=10.0	0 mA	10 mA	see relay chart	16.0A 8.0A/common ^⑥
	5-265V ac 5-125V dc	16	8	1746-OW16 ^③ (RTB)	0.170	0.180	on=10.0 off=10.0	0 mA	10 mA	see relay chart	16.0A 8.0A/common ^⑥
	5-265V ac 5-125V dc	8	individually isolated	1746-OX8 ^④ (RTB)	0.085	0.090	on=10.0 off=10.0	0 mA	10 mA	see relay chart	⑥

① A fused common and blown fuse LED are provided on this module.

② Use the following ID codes when configuring your system with your programming software or the Hand-held Terminal: 1746-OBP8 = 2721 and 1746-OAP12 = 2803.

③ Certified for Class I, Division 2 hazardous location by CSA only.

④ Ribbon cable connector. User must construct cable or purchase 1492-series pre-wired cable.

⑤ This product does not have CE certification.

⑥ The continuous current per module must be limited to 1440 VA (max.).

Relay Contact Rating Chart

Type	Max. Volts	Amperes ^①		Amps Continuous ^③	Volt-Amperes	
		Make	Break		Make	Break
Relay Contact Ratings for OW4, OW8, and OW16	240V ac 120V ac	7.5A 15.0A	0.75A 1.50A	2.5A	1800 VA	180 VA
	125V dc	0.22A ^②		1.0A	28 VA	
	24V dc	1.2A ^②		2.0A	28 VA	

Type	Max. Volts	Amperes		Amps Continuous	Volt-Amperes	
		Make	Break		Make	Break
Relay Contact Ratings for OX8	240V ac 120V ac	15.0A 30.0A	1.5A 3.0A	5.0A	3600 VA	360 VA
	125V dc	0.22A		1.0A	28 VA	
	24V dc	1.2A		2.0A	28 VA	

① Connecting surge suppressors across your external load will extend the life of SLC 500 relay contacts. For relay contact outputs, consult the SLC 500 Installation and Operation User Manual (Catalog Number 1747-6.2).

② For DC voltage applications, the make/break ampere rating for relay contacts can be determined by dividing 28 VA by the applied DC voltage. For example, 28 VA/48V dc = 0.58A. For DC voltage applications less than 48V, the make/break ratings for relay contacts cannot exceed 2A. For DC voltage applications greater than 48V, the make/break ratings for relay contacts cannot exceed 1A.

③ The continuous current per module must be limited so the module power does not exceed 1440 VA.

1746 Discrete Combination Modules

Voltage Category	Operating Voltage	Points Per Module	Points Per Common	Catalog Number	Backplane Current Draw (Amps)		Specification Reference
					5 V	24 V	
Inputs-120V ac	85-132V ac	2 inputs 2 outputs	2	1746-IO4 ^{①②}	0.030	0.025	See specifications for Catalog Numbers 1746-IA4 and 1746-OW4
Relay Outputs 100/120V ac	5-265V ac 5-125V dc	4 inputs 4 outputs	4	1746-IO8 ^{①②}	0.060	0.045	Continuous Current for IO4 is 4.0A Continuous Current for IO8 is 8.0A
		6 inputs 6 outputs	6	1746-IO12 ^{①②}	0.090	0.070	See specifications for Catalog Numbers 1746-IA16 and OW16 Continuous Current for IO12 is 8.0A

① Certified for Class I, Division 2 hazardous location by CSA only.

② This product does not have CE certification.

Bulletin 1492 Interface Modules and Cables

Allen-Bradley's new wiring system for programmable controllers reduces installation time and increases start-up success. Comprised of a Bulletin 1492 Interface Module and a pre-wired cable, this wiring system can eliminate up to 50 percent of the point-to-point wiring between the programmable controller and field devices. Available for many of the SLC 500 and PLC[®] 16- and 32-point I/O modules, the wiring system provides a lower probability for wiring errors. Optional LEDs on the Interface Module indicate the on/off status of input and output devices, aiding in troubleshooting your wiring system. For more information refer to Publication 1492-1.6.

Specialty I/O Modules

The SLC 500 family offers specialty I/O modules that enhance your control system. These modules range from analog, motion control, and communication to provide a unique, easy to use interface between the modules and the processor. The following section provides an overview of our specialty I/O modules.

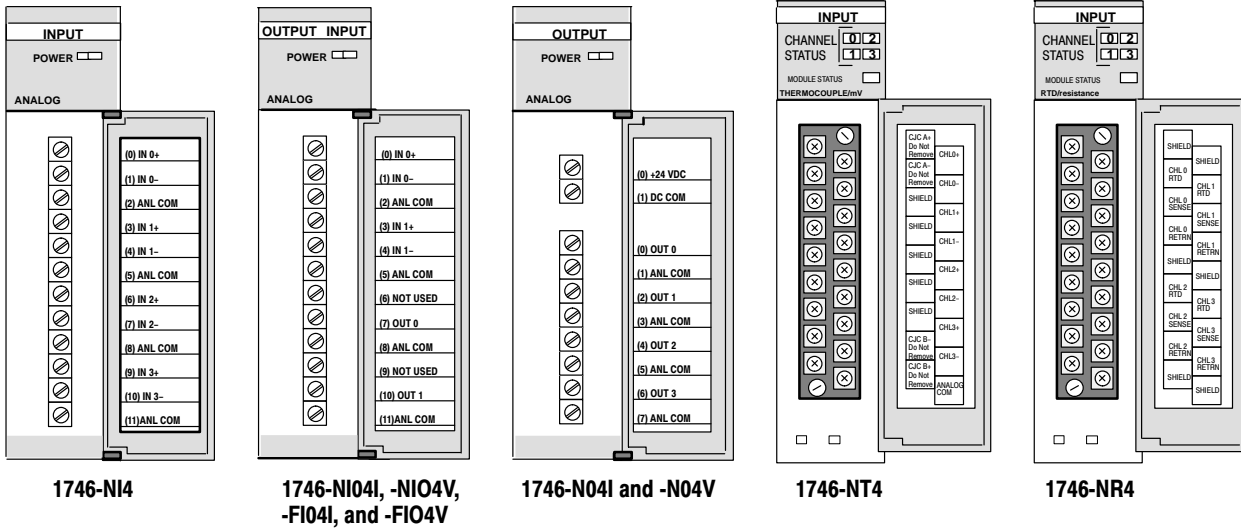

1746 I/O Analog Modules

The SLC 500 family offers nine different analog I/O modules for your control applications.

- NI4 input module
- NIO4I, NIO4V, FIO4I, and FIO4V input/output modules
- NO4I and NO4V output modules
- NT4 Thermocouple/mV input module
- NR4 RTD/resistance input module

Features

- High resolution
- Backplane powered
- User selectable inputs
- Input filtering
- Image maps directly into the SLC™ image

Benefits

- 12-bit input for the FIO4I and FIO4V and 16-bit input for NI4, NIO4I, and NIO4V. 14-bit output converters on all the modules provide accurate control capabilities.
- No external power supply required, reducing system cost.
- Configurable per channel.
- Provides higher immunity to electrical noise (Nxxx) or a faster input response (Fxxx) modules.
- Saves memory usage and time.

The following pages provides individual module specifications.

Catalog Number 1746-	Input Channels per Module	Output Channels per Module	Backplane Current Draw	External 24V dc Power Supply Tolerance
NI4	4 differential, voltage or current selectable per channel	Not applicable	25 mA at 5V dc 85 mA at 24V dc	Not Applicable
NIO4I	2 differential, voltage or current selectable per channel	2 current outputs not individually isolated	55 mA at 5V dc 145 mA at 24V dc	Not Applicable
NIO4V	2 differential, voltage or current selectable per channel	2 voltage outputs, not individually isolated	55 mA at 5V dc 115 mA at 24V dc	Not Applicable
NO4I	Not applicable	4 current outputs, not individually isolated	55 mA at 5V dc 195 mA at 24V dc	24 ±10% at 195 mA (21.6 to 26.4V dc)
NO4V	Not applicable	4 voltage outputs, not individually isolated	55 mA at 5V dc 145 mA at 24V dc	24 ±10% at 145 mA (21.6 to 26.4V dc)
FIO4I	2 differential, voltage or current selectable per channel	2 current outputs, not individually isolated	55 mA at 5V dc 150 mA at 24V dc	Not Applicable
FIO4V	2 differential, voltage or current selectable per channel	2 voltage outputs, not individually isolated	55 mA at 5V dc 120 mA at 24V dc	Not Applicable

Important: All analog modules are isolated from each other and from the backplane. If the NO4I or the NO4V is externally powered, the 24V dc backplane current draw is 0 mA.

Specifications

The specifications for the analog modules are the same as shown in the *Specifications* on page 15 for the modular controller, with the following additions:

Description	Specification
SLC Communication Format	16-bit Two's Complement Binary
Field Wiring to Backplane Isolation	500V dc
Conversion Time	512 μ s for all channels in parallel
Current/Voltage Ranges	
NI4	\pm 10V dc or \pm 20 mA (input)
NIO4I	\pm 10V dc or \pm 20 mA (input), 0 to 21 mA (output)
NIO4V	\pm 10V dc or \pm 20 mA (input), \pm 10V dc (output)
NO4I	0 to 21 mA (current output)
NO4V	\pm 10 V (voltage output)
FIO4I	0 to 10V or 0 to 21 mA (input), 0 to 21 mA (output)
FIO4V	0 to 10V or 0 to 21 mA (input), \pm 10V (output)
Step Response (NI4, NIO4I, NIO4V, NO4I, and NO4V)	
Input	60 ms at 95%
Output	2.5 ms at 95%
Step Response (FIO4I, FIO4V)	
Input	100 μ s at 95%
Output	2.5 ms at 95%
Maximum Wire Size	14 AWG
Terminal Block	Removable
Recommended Cable	Belden #8761
Input A/D Converter (NI4, NIO4I, NIO4V, NO4I, and NO4V)	16-bit
Input A/D Converter (FIO4I, FIO4V)	12-bit

1746-NT4 Thermocouple/mV Module

The thermocouple/mV module receives and stores digitally converted thermocouple and/or DC millivolt (mV) analog data into its image table for retrieval by all fixed and modular SLC 500 processors.

Features

Cold-junction compensation and linearization

Four selectable filters

Individual channel configuration

Benefits

Provides accurate process digital temperature readings.

Allows you to tailor system response to your environment.

Allows you to mix millivolt and thermocouple types.

The 1746-NT4 module converts input signals from the following input types.

Thermocouple Temperature Ranges

Type of Thermocouple Input	° C Temperature Range	° F Temperature Range	Accuracy (Max. error at 25° C/77° F)
Type J	-210° C to 760° C	-346° F to 1400° F	±1.06° C
Type K	-270° C to 1370° C	-454° F to 2498° F	±1.72° C
Type T	-270° C to 400° C	-454° F to 752° F	±1.43° C
Type E	-270° C to 1000° C	-454° F to 1832° F	±0.72° C
Type N	0° C to 1300° C	32° F to 2372° F	±1.39° C
Type R	0° C to 1768° C	32° F to 3214° F	±3.59° C
Type S	0° C to 1768° C	32° F to 3214° F	±3.61° C
Type B	300° C to 1820° C	572° F to 3308° F	±3.12° C

DC Millivolt Input Ranges

Millivolt Input Type	Range	Accuracy (Max. error at 25° C/77° F)
± 50 mV	-50 mV dc to +50 mV dc	50 µV
± 100 mV	-100 mV dc to +100 mV dc	50 µV

Specifications

The specifications for the Thermocouple/mV module are the same as shown in the *Specifications* on page 15 for the modular controller, with the following additions:

Specification	Description
Backplane Current Draw 5V dc 24V dc	60 mA 40 mA
Temperature Scale Resolution (selectable)	° C of ° F and 0.1° C or 0.1° F
Millivolt Scale Resolution (selectable)	0.1 millivolt and 0.01 millivolt (mV)
Open Circuit Method	Upscale
Input Step Response	300 ms at 10 Hz 60 ms at 50 Hz 50 ms at 60 Hz 12 ms at 250 Hz
Thermocouple Linearization	IPTS-68 standard, NBS MN-125, NBS MN-161
Maximum Cable Impedance	25 ohms max. loop impedance for <1LSB error
Calibration	Autocalibration at power-up and when a channel is enabled.
Isolation	500V dc continuous between inputs and chassis ground, and between inputs and backplane.
Isolation between channels	None.
Maximum Channel-to-Channel Common-mode Separation	2V maximum between any two channels (Series B) ^①
Recommended Cable for thermocouple inputs for mV inputs	Appropriate shielded thermocouple extension wire ^② Belden #8761 or equivalent (shielded twisted pair)
Maximum Wire Size	Two 14 AWG wires per terminal

^① Allows use with a single or multiple grounded thermocouples as long as the grounds are within 2 volts of each other. Series A modules offer zero volts separation and can be used with a single grounded thermocouple. Both Series A or B can be used with multiple ungrounded thermocouples.

^② Refer to the thermocouple manufacturer for the correct extension wire.

1746-NR4 RTD/resistance Input Module

The RTD/resistance input module enhances the present temperature control capabilities of your SLC 500 fixed or modular system by providing the capability to interface with 12 different RTDs and 4 different direct resistance ranges. RTDs are known for their accuracy, repeatability, linearity, and long-term stability.

Features

Module interface compatibility with a number of different RTDs

Two selectable excitation current levels (0.5 and 2.0 mA)

Four selectable filters

Individual channel configuration

Benefits

Allows you to choose the best RTD for your temperature application.

Provides capability to limit RTD self heating and to provide greater temperature accuracy.

Allows you to tailor system response to your environment.

Allows you to mix RTD and resistance device types.

RTD Temperature Ranges, Resolution, and Repeatability

RTD Type		Temp. Range (0.5 mA Excitation) ^①	Temp. Range (2.0 mA Excitation) ^①	Resolution	Repeatability
Platinum (385) ^②	100Ω	-200° C to +850° C (-328° F to +1562° F)	-200° C to +850° C (-328° F to +1562° F)	0.1° C (0.2° F)	±0.2° C (±0.4° F)
	200Ω	-200° C to +850° C (-328° F to +1562° F)	-200° C to +850° C (-328° F to +1562° F)	0.1° C (0.2° F)	±0.2° C (±0.4° F)
	500Ω	-200° C to +850° C (-328° F to +1562° F)	-200° C to +850° C (-328° F to +1562° F)	0.1° C (0.2° F)	±0.2° C (±0.4° F)
	1000Ω	-200° C to +850° C (-328° F to +1562° F)	-200° C to +240° C (-328° F to +464° F)	0.1° C (0.2° F)	±0.2° C (±0.4° F)
Platinum (3916) ^②	100Ω	-200° C to +630° C (-328° F to +1166° F)	-200° C to +630° C (-328° F to +1166° F)	0.1° C (0.2° F)	±0.2° C (±0.4° F)
	200Ω	-200° C to +630° C (-328° F to +1166° F)	-200° C to +630° C (-328° F to +1166° F)	0.1° C (0.2° F)	±0.2° C (±0.4° F)
	500Ω	-200° C to +630° C (-328° F to +1166° F)	-200° C to +630° C (-328° F to +1166° F)	0.1° C (0.2° F)	±0.2° C (±0.4° F)
	1000Ω	-200° C to +630° C (-328° F to +1166° F)	-200° C to +230° C (-328° F to +446° F)	0.1° C (0.2° F)	±0.2° C (±0.4° F)
Copper (426) ^{②③}	10Ω	Not Allowed ^④	-100° C to +260° C (-148° F to +500° F)	0.1° C (0.2° F)	±0.2° C (±0.4° F)
Nickel (618) ^{②⑤}	120Ω	-100° C to +260° C (-148° F to +500° F)	-100° C to +260° C (-148° F to +500° F)	0.1° C (0.2° F)	±0.1° C (±0.2° F)
Nickel (672) ^{②⑤}	120Ω	-80° C to +260° C (-112° F to +500° F)	-80° C to +260° C (-112° F to +500° F)	0.1° C (0.2° F)	±0.1° C (±0.2° F)
Nickel Iron (518) ^{②⑥}	604Ω	-100° C to +200° C (-148° F to +392° F)	-100° C to +200° C (-148° F to +392° F)	0.1° C (0.2° F)	±0.1° C (±0.2° F)

^① The temperature range for the 1000Ω RTD is dependant on the excitation current.

^② The digits following the RTD type represent the temperature coefficient of resistance (α), which is defined as the resistance change per ohm per ° C. For instance, *Platinum 385* refers to a platinum RTD with $\alpha = 0.00385$ ohms/ohm -° C or simply 0.00385 /° C.

^③ Actual value at 0° C (32° F) is 9.042Ω per SAMA standard RC21-4-1966.

^④ To maximize the relatively small RTD signal, only 2 mA excitation current is allowed.

^⑤ Actual value at 0° C (32° F) is 100Ω per DIN standard.

^⑥ Minco Type 'NA' (Nickle) and Minco Type 'FA' (Nickle-Iron)

RTD Accuracy and Temperature Drift Specifications

RTD Type		Accuracy ^① (0.5 mA Excitation)	Accuracy ^① (2.0 mA Excitation)	Temperature Drift ^② (0.5 mA Excitation)	Temperature Drift ^② (2.0 mA Excitation)
Platinum (385) ^④	100Ω	±1.0° C ^③ (±2.0° F)	±0.5° C (±0.9° F)	±0.034° C/° C (±0.061° F/° F)	±0.014° C/° C (±0.025° F/° F)
	200Ω	±1.0° C ^③ (±2.0° F)	±0.5° C (±0.9° F)	±0.034° C/° C (±0.061° F/° F)	±0.014° C/° C (±0.025° F/° F)
	500Ω	±0.6° C (±1.1° F)	±0.5° C (±0.9° F)	±0.017° C/° C (±0.031° F/° F)	±0.014° C/° C (±0.025° F/° F)
	1000Ω	±0.6° C (±1.1° F)	±0.5° C (±0.9° F)	±0.017° C/° C (±0.031° F/° F)	±0.014° C/° C (±0.025° F/° F)
Platinum (3916) ^④	100Ω	±1.0° C ^③ (±2.0° F)	±0.4° C (±0.7° F)	±0.034° C/° C (±0.061° F/° F)	±0.011° C/° C (±0.020° F/° F)
	200Ω	±1.0° C ^③ (±2.0° F)	±0.4° C (±0.7° F)	±0.034° C/° C (±0.061° F/° F)	±0.011° C/° C (±0.020° F/° F)
	500Ω	±0.5° C (±0.9° F)	±0.4° C (±0.7° F)	±0.014° C/° C (±0.025° F/° F)	±0.011° C/° C (±0.020° F/° F)
	1000Ω	±0.5° C (±0.9° F)	±0.4° C (±0.7° F)	±0.014° C/° C (±0.025° F/° F)	±0.011° C/° C (±0.020° F/° F)
Copper (426) ^{④⑤}	10Ω	Not Allowed ^⑥	±0.6° C (±1.1° F)	Not Allowed ^⑥	±0.017° C/° C (±0.031° F/° F)
Nickel (618) ^{④⑦}	120Ω	±0.2° C (±0.4° F)	±0.2° C (±0.4° F)	±0.008° C/° C (±0.014° F/° F)	±0.008° C/° C (±0.014° F/° F)
Nickel (672) ^④	120Ω	±0.2° C (±0.4° F)	±0.2° C (±0.4° F)	±0.008° C/° C (±0.014° F/° F)	±0.008° C/° C (±0.014° F/° F)
Nickel Iron (518) ^④	604Ω	±0.3° C (±0.5° F)	±0.3° C (±0.5° F)	±0.010° C/° C (±0.018° F/° F)	±0.010° C/° C (±0.018° F/° F)

① The accuracy values assume that the module was calibrated within the specified temperature range of 0° C to 60° C (32° F to 140° F).

② Temperature drift specifications apply to a module that has not been calibrated.

③ Module accuracy, using 100Ω or 200Ω platinum RTDs with 0.5 mA excitation current, depends on the following criteria:

(a) Module accuracy is ±0.6° C after you apply power to the module or perform an autocalibration at 25° C (77° F) ambient with module operating temperature at 25° C (77° F).

(b) Module accuracy is $\pm(0.6° C + \Delta T \times 0.034° C/° C)$ after you apply power to the module or perform an autocalibration at 25° C (77° F) ambient with the module operating temperature between 0° C to 60° C (32° F to 140° F).

—where ΔT is the temperature difference between the actual operating temperature of the module and 25° C (77° F) and 0.034° C/° C is the temperature drift shown in the table above for 100Ω or 200Ω platinum RTDs.

(c) Module accuracy is ±1.0° C after you apply power to the module or perform an autocalibration at 60° C (140° F) ambient with module operating temperature at 60° C (140° F).

④ The digits following the RTD type represent the temperature coefficient of resistance (α), which is defined as the resistance change per ohm per °C. For instance, *Platinum 385* refers to a platinum RTD with $\alpha = 0.00385$ ohms/ohm -°C or simply 0.00385 / °C.

⑤ Actual value at 0° C (32° F) is 9.042Ω per SAMA standard RC21-4-1966.

⑥ To maximize the relatively small RTD signal, only 2 mA excitation current is allowed.

⑦ Actual value at 0° C (32° F) is 100Ω per DIN standard.

Resistance Input Specifications

Input Type	Resistance Range (0.5 mA Excitation)	Resistance Range (2.0 mA Excitation)	Accuracy ^①	Temperature Drift	Resolution	Repeatability	
Resistance	150Ω	0Ω to 150Ω	0Ω to 150Ω	^②	^③	0.01Ω	±0.04Ω
	500Ω	0Ω to 500Ω	0Ω to 500Ω	±0.5Ω	±0.014Ω/°C (±0.025Ω/°F)	0.1Ω	±0.2Ω
	1000Ω	0Ω to 1000Ω	0Ω to 1000Ω	±1.0Ω	±0.029Ω/°C (±0.052Ω/°F)	0.1Ω	±0.2Ω
	3000Ω	0Ω to 3000Ω	0Ω to 1900Ω	±1.5Ω	±0.043Ω/°C (±0.077Ω/°F)	0.1Ω	±0.2Ω

^① The accuracy values assume that the module was calibrated within the specified temperature range of 0° C to 60° C (32° F to 140° F).

^② The accuracy for 150Ω is dependant on the excitation current:

±0.2Ω at 0.5 mA

±0.15Ω at 2.0 mA

^③ The temperature drift for 150Ω is dependant on the excitation current:

±0.006Ω/°C at 0.5 mA

±0.004Ω at 2.0 mA

Specifications

The specifications for the RTD/resistance input module are the same as shown in the *Specifications* on page 15 for the modular controller, with the following additions:

Specification	Description
Backplane Current Draw 5V dc 24V dc	50 mA 50 mA
Temperature Scale Resolution (selectable)	1° C or 1° F and 0.1° C or 0.1° F
Resistance Scale Resolution (selectable)	1Ω or 0.1Ω for all resistance ranges. In addition, 0.01Ω for 150Ω range.
RTD Excitation Current	Two current values are user-selectable (0.5 mA and 2.0 mA) ^①
Open circuit or short circuit Method	Zero, upscale or downscale
Input Step Response	300 ms at 10 Hz 60 ms at 50 Hz 50 ms at 60 Hz 12 ms at 250 Hz
Maximum Cable Impedance	25 ohms maximum per 1000 feet
Maximum Wire Size	Two 24 AWG wires per terminal
Calibration	Autocalibration at power-up and when a channel is enabled.
Isolation Between Channels	None
Isolation	500V dc continuous between inputs and chassis ground, and between inputs and backplane.
Common mode voltage separation	±1 volt

^① Refer to the current recommendations of the RTD manufacturer to determine the best current source for your application.

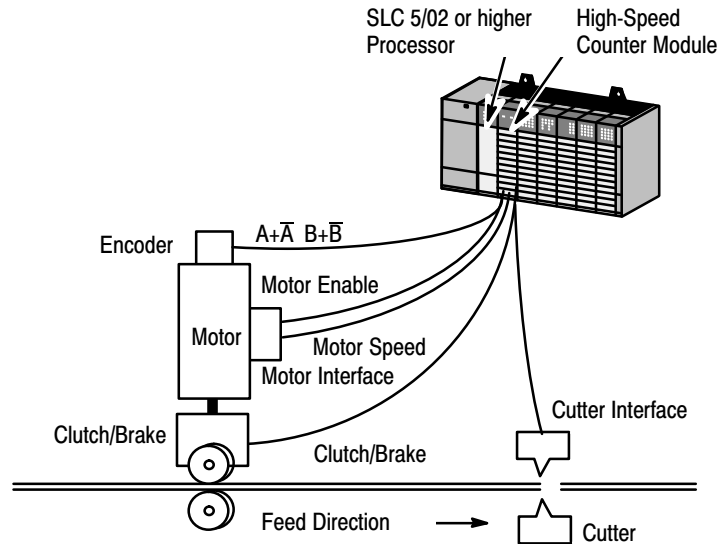

1746-HSCE High-Speed Counter Module

The High-Speed Counter Module provides bidirectional counting of high speed inputs from quadrature encoders and various high-speed switches. This single channel accepts input pulse frequencies of up to 50k Hz, allowing precise control of fast motions. This module is compatible with the SLC 5/02 and higher processors.

In addition to providing an Accumulated Count, the module provides the Rate Measurement indicating the pulse frequency in Hertz (Hz). The Rate Measurement is determined by accumulating input pulses over a fixed period of time. The dynamically configurable Rate Period ranges from 10 milliseconds to 2.55 seconds.

Features

Three modes of operation
(Range, Rate, and Sequencer)
Four on-board open collector
outputs

Benefits

Allows you to select the best mode to
fit your application.
Allows control, independent of the
SLC processor scan by the module.

Specifications

The specifications for the High-Speed Counter module are the same as shown in the *Specifications* on page 15 for the modular controller, with the following additions:

Description	Specification
Backplane Current Draw	
5V dc	320 mA
24V dc	0.0 mA
Maximum Input Frequency	
Sequencer and Range	50k Hz
Rate	32.767k Hz

1746-HSTP1 Stepper Controller Module

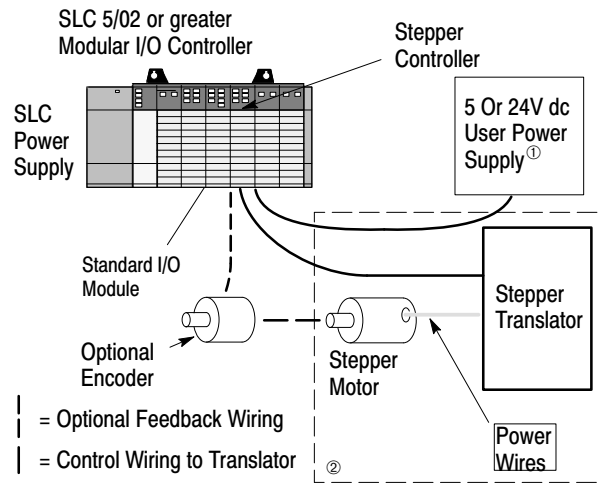

① The 24V may be obtained from the SLC Power Supply depending on application power requirements.

② Motor and translator furnished by the customer.

The Stepper Controller Module is a SLC family compatible module that provides single axis control for micro-stepping applications. This single slot module operates with a wide variety of SLC 500 processors and compatible encoders. The user can program the module for either incremental or absolute moves, depending on the application. The module is programmed with Advanced Programming Software.

Features

SLC 500 interface

Over $\pm 8,000,000$ counts of absolute positioning at pulse train velocities of up to 250K Hz.

Translator compatibility

Encoder compatibility

Programmable modes of operation (Configuration, Command, and Diagnostic)

Five LED status indicators

Built-in loop back diagnostics

Benefits

Works with SLC 500 processors.

Provides accurate positioning of a mechanism to a precise point.

User can configure module for translators requiring either a pulse train/direction input or a CW/CCW pulse train input to operate.

Accepts position feedback from a single encoder for closed loop operation.

Eliminates the need for DIP switches to set for operation and configuration.

Provides quick status information and troubleshooting help.

Permits monitoring of the pulse train commands issued to the stepper motor driver/translator.

The backplane current draw at 5V dc is 0.2 Amps and 0.09 Amps (max.) at 24V dc.

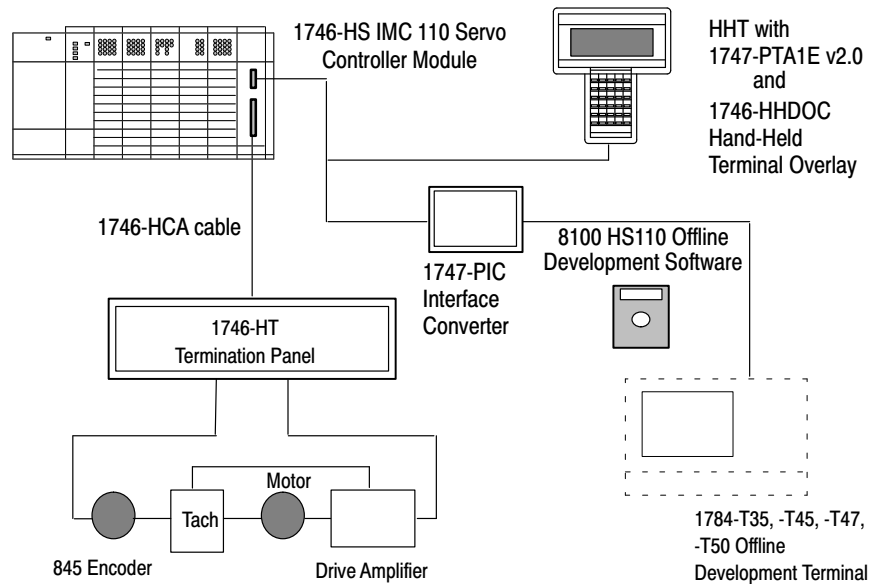

1746-HS IMC™ 110 Servo Positioning Module

The IMC 110 Motion Control System is a single-axis closed loop servo positioning module that plugs into a single slot of the SLC 500 programmable controller. When used with servo drives, motors and encoders, the IMC 110 becomes the key component of a low cost and powerful motion control system. Motion Management Language (MML) and Graphical Motion Control Language (GML) provide two easy-to-use offline programming tools, which aid you in debugging and graphics interface.

The IMC 110 replaces mechanical methods of controlling machine speed and position. The IMC 110 directs the movement of a single axis, or shaft, through a pre-programmed sequencer, while it monitors an encoder for position feedback.

Features

- Four fast I/O points
- +10V dc signal
- 5 ms Servo Loop Closure Rate
- SLC 500 Interface
- Termination Panel Interface

Benefits

- Controlled by the IMC 110 system, saving valuable throughput time.
- Provides an interface to most servo drives.
- Provides a high degree of accuracy and system response.
- Supports either an SLC 500 fixed or modular system.
- Provides a wiring connection for fast I/O, E-stop, power supplies, drive command and encoder feedback.

The backplane current draw at 5V dc is 0.36 Amps and 0 Amps at 24V dc.

Remote I/O Modules

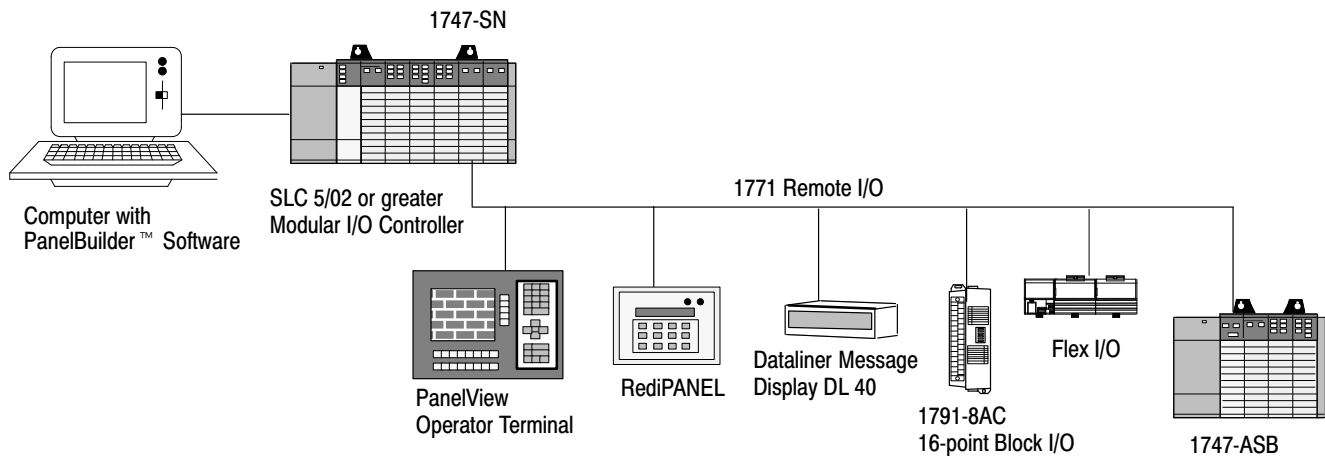

1747-SN Remote I/O Scanner

The Remote I/O Scanner provides high-speed remote communication between an SLC processor and Allen-Bradley operator interface and control devices. The scanner provides connectivity of your SLC 5/02 or higher processor to devices such as RediPANEL, DL40 Dataliner, PanelView, all versions of Block I/O, Allen-Bradley drives, and 1771 I/O devices. Refer to page 37 for a brief description of these products.

The Series A Remote I/O scanner does not support block transfer operations. The Series B scanner supports block transfer of up to 64 words of data. The Remote I/O Scanner features the following:

Features

- Selectable baud rates (57.6, 115.2, and 230.4K baud)
- RIO link cable length of 3050 m (10,000 ft) (max.)
- Supports connection of up to 16 physical devices
- Block transfers to RIO adapter devices
- Supports Remote I/O passthru (SLC 5/03 and SLC 5/04 processors)

Benefits

- Provides noise immunity over various cable distances.
- Allows for distribution of devices over a wide physical area.
- Provides a wide range of applications to be addressed.
- Sends large amounts of data to RIO devices without effecting total system throughput.
- Allows you to download and change applications in PanelView and dataliner devices.

1747-ASB Remote I/O Adapter Module

The Remote I/O Adapter module is a single-slot, RIO communication link module. It occupies the first slot (slot 0) of a 1746 remote chassis, where the SLC processor normally resides. The ASB module acts as a gateway between an SLC 500 scanner and the I/O modules in the 1747-ASB remote and expansion chassis.

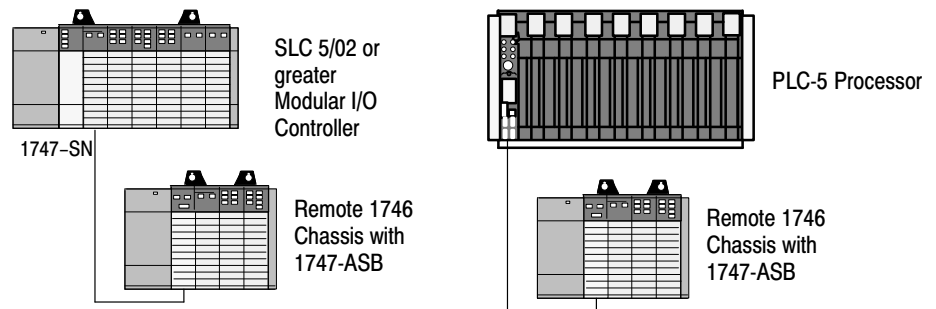

The ASB module is compatible with all Allen-Bradley RIO scanners. The Remote I/O Adapter module features the following:

Features

Supports 1/2-slot, 1-slot, and 2-slot addressing modes

Monitor three 7-segment displays

Secure I/O and DIP switch configurations

Benefits

Provides efficient image utilization by allowing you to assign the amount of image space required per slot.

Provides status information and troubleshooting.

Allows you to inhibit operation if the configuration or DIP switch settings were modified since the last save.

Specifications for 1747-SN and 1747-ASB

The specifications for the 1747-SN and 1747-ASB are the same as shown in the *Specifications* on page 15 for the modular controller, with the following additions and exception (for example, operating temperature for 1747-SN):

Specification	SN	ASB
Backplane Current Draw	900 mA at 5V dc	375 mA at 5V dc
Compatible Remote I/O Link Cable	Belden 9463	
Extended Node Support	Yes	
Operating temperature (1747-SN)	0° C to +55° C (+32° F to +131° F)	

Remote I/O Specifications

Baud Rate	Cable Distance
57.6K baud	3050 m (10,000 ft)
115.2K baud	1524 m (5,000 ft)
230.4K baud	762 m (2,500 ft)

1747-DCM Direct Communication Module

The Direct Communication Module (DCM) links the SLC 500 controller to the Allen-Bradley PLC for distributed processing. The DCM acts as a remote I/O adapter on a remote I/O link. Information is transferred between a local PLC or SLC scanner and a remote 1747-DCM module during each remote I/O scan. The number of DCMs that a scanner can supervise depends on the number of racks the scanner supports and the rack size of the DCM. Each SLC 500 fixed controller with a Catalog Number 1746-A2 expansion rack supports one DCM. The SLC 500 modular controllers can support multiple DCMs.

The DCM can be configured for one of the following:

- 1/4 rack = 2 words (1 remote I/O word and 1 status word)
- 1/2 rack = 4 words (3 remote I/O words and 1 status word)
- 3/4 rack = 6 words (5 remote I/O words and 1 status word)
- full rack = 8 words (7 remote I/O words and 1 status word)

Specifications

The specifications for the Direct Communication Module are the same as shown in the *Specifications* on page 15 for the modular controller, with the following additions:

Description	Specification
Backplane Current Draw	
5V dc	0.36A
24V dc	0.00A
Baud Rate	Maximum Cable Distance
57.6K Baud	3048 m (10,000 ft)
115.2K Baud	1524 m (5,000 ft)
230.4K Baud	762 m (2,500 ft)
Operating Temperature	0° C to 55° C (+32° F to 131° F)

Remote I/O Devices

The following remote I/O devices interface with the SLC 500 remote I/O modules.

1791 Block I/O

Block I/O is a self-contained I/O interface that provides the functionality of the I/O rack, adapter, power supply, and I/O module in a single interface. The block communicates over the Allen-Bradley remote I/O network, joining other Allen-Bradley devices such as operator interface, drives, remote I/O chassis, and vision systems. For additional information refer to Publication 1791-1.3.

1794 Flex I/O

Flex I/O is a flexible, compact I/O system that saves engineering, installation and troubleshooting time. Flex I/O consists of interchangeable components that you select for your specific needs. The parts snap together easily, creating a compact I/O system for your SLC and PLC controllers. Extra hardware and wiring are eliminated by combining the I/O module and terminal block into a single unit. For additional information refer to Publication 1794-2.1.

2705 RediPANEL Operator Modules

RediPANEL Operator modules combine push buttons, wiring, I/O modules, a message display, and other control panel components in a single pre-packaged, ready-to-install unit. For additional information refer to Publication 2705-1.0.

2706 Dataliner Message Displays

The Dataliner Message Displays provide a cost-effective means of communicating essential machine or process status, alarm conditions, and operator prompts across a machine or a large plant floor. For additional information refer to Publication 2706-1.0.

Drives

Adjustable frequency AC drives and high performance DC drives provide exceptional reliability in critical motor control applications. They offer process control, energy savings, and communication to I/O devices such as PanelView terminals through the SLC 500 modular controller. For additional information refer to Publication DHQ-6.

Pyramid Solutions Program (PSP)

The Pyramid Solutions Program provides additional third-party products that interface to remote I/O. For additional information refer to Publication PSP-5.1.

DeviceNet Network

A device network connects plant floor devices directly to the control system (e.g., SLC 500 modular controller) reducing the number of I/O interfaces and wiring associated with a typical hard-wired solution. The DeviceNet communication network is a completely open device network and has the support of industry's leading sensor, actuator, and control manufacturers.

In a typical configuration, the 1747-SDN DeviceNet Scanner acts as an interface between DeviceNet devices and the SLC 5/02, SLC 5/03, and SLC 5/04 processors. The scanner communicates with DeviceNet devices over the network to:

- read inputs from a device
- write outputs to a device
- download configuration data
- monitor a device's operational status

The scanner communicates with the SLC 500 modular processors to exchange I/O data. Information exchanged includes:

- device I/O data
- status information
- configuration data

A single scanner (master) can communicate with up to 63 nodes (slaves) on DeviceNet. The SLC system supports multiple scanners if more devices are required to be controlled by a single SLC 500 processor.

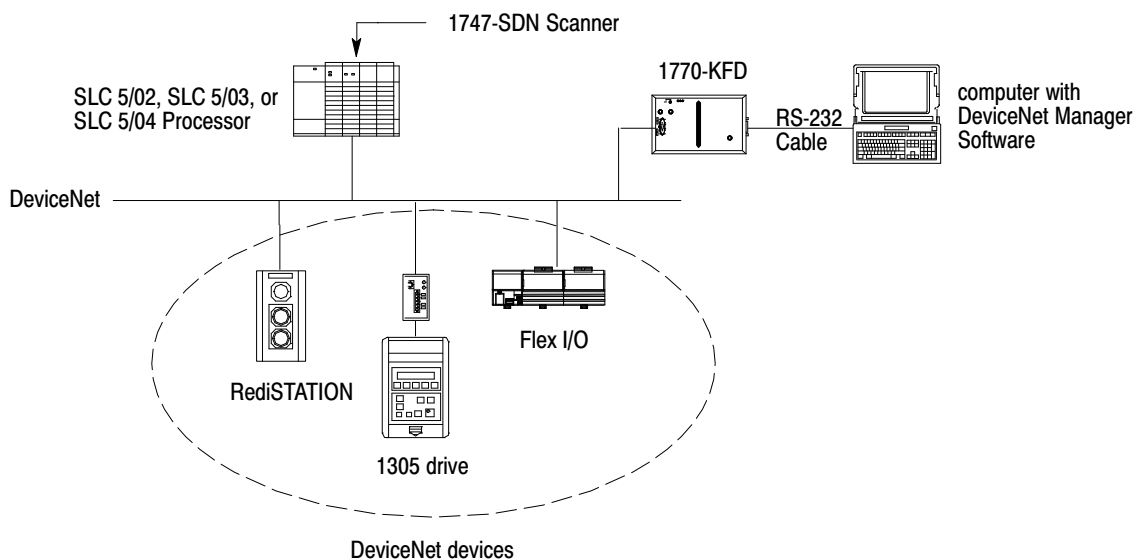

DeviceNet Network Length

The DeviceNet network lengths are listed below.

Network Length	Baud Rate
100 m (328.08 ft)	500K baud
200 m (656.16 ft)	250K baud
500 m (1640.42 ft)	125K baud

Remote Communication

SLC 500 products communicate to serial devices using the following interface products.

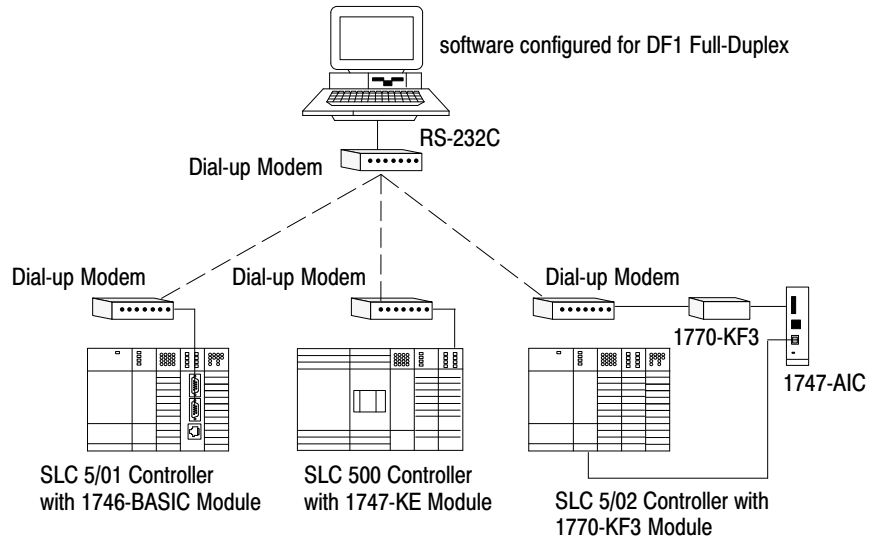

Only dial-up modems can be used in the above configuration.

1747-KE DH-485/RS-232C Interface Module

The DH-485/RS-232C Interface module provides a bridge between the DH-485 communication network and RS-232 using Allen-Bradley's DF1 communication protocol. When used in a SLC 500 chassis with a modem, you can:

- remotely program and troubleshoot any single SLC 500 processor
- remotely communicate to a DH-485 network of SLC 500 processors
- remotely collect data directly from the data table of any SLC 500 processor
- use the SLC 500 as a remote terminal unit

1746-BAS BASIC Module and BASIC Development Software

The SLC 500 BASIC module provides two configurable serial channels (RS-232/423, RS-422, and RS-485) and one DH-485 channel, up to 24K bytes of battery-backed RAM, plus an additional 32K bytes of EEPROM. Using either the 1747-PBASE development software or terminal emulation software, you can use the BASIC module to:

- interface to modems (DF1 full- or half-duplex) for transferring data from any SLC 500 processor to other DF1 devices at remote locations
- provide RTU functionality including dial-up and report by exception
- generate and print reports
- perform floating point math functions
- remotely communicate via other protocols using the ProSoft chips

1770-KF3 DH-485 Communication Interface Module

The DH-485 Communication Interface module is a standalone device that provides the same functionality as the 1747-KE interface module. However, when communicating from a remote location to a DH-485 network, the 1770-KF3 does not require a 1747-AIC module.

Remote Communication Functions

The above communication modules connect to most types of dial-up network or direct connect modems. The following modems can be used:

- Manual – typically acoustically coupled modems
- DTE Controlled Answer – attached to phone lines
- Auto Answer – automatically answers and hangs-up the phone
- Direct Connect – connected to a dedicated, leased phone line

The following table shows how serial devices interface with SLC 500 products.

Feature	1770-KF3	1747-KE	1746-BAS
Advanced Programming Software functions supported	•	•	NA
Module specific programming language	NA	NA	•
External power required	•	NA	NA
Standalone "desktop"	•	NA	NA
SLC 500 I/O module	NA	•	•
Terminal required for configuration	NA	NA	•
Descriptive configuration menus	NA	•	NA
Dial-up modem support	NA	•	•
Link coupler required for point-to-point communication	•	NA	NA
Link coupler required for network communication	NA	•	•
DH-485 support	•	•	•
DH-485 token passing master	•	•	•
DF1 Full-duplex support	•	•	•
DF1 Half-duplex slave – local mode	•	•	•
DF1 Half-duplex slave – remote mode	•	•	•
Responds to polls from DF1 half-duplex master	•	•	•
Report by exception capability	NA	•	•
ProSoft Protocol Chip support	NA	NA	•

NA (Not Applicable)

Networking Options

SLC 500 programmable controllers communicate across an embedded DH-485 network for program support and monitoring. The following products provide networking options for the SLC 500 programmable controllers.

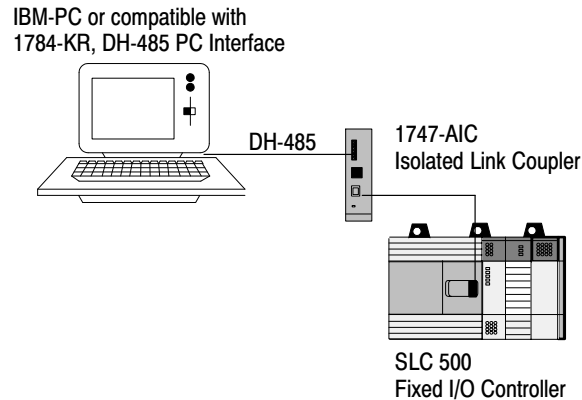

1784-KR Personal Computer Interface Card

The Personal Computer Interface Card provides an interface for IBM XT/AT and compatible computers to communicate over the Allen-Bradley DH-485 communication network. This includes communication to the Allen-Bradley line of SLC 500 programmable controllers.

Features

PC XT/AT Interface to
DH-485

DH-485 isolation

Reduced personal computer
overhead

Benefits

Eliminates the need for the personal
interface converter when using
Advanced Programming Software.

Eliminates the need for an isolated
link coupler.

Provides a faster update time for the
user interface through the
co-processor.

Specifications

The specifications for the Personal Computer Interface Card are the same as shown in the *Specifications* on page 15 for the modular controller, with the following additions:

Description	Specification
Power Requirements	5V dc, 1.8A
Outputs	RS-485 electrical/DH-485 protocol
Hardware Interrupt	IRQ2, IRQ3, IRQ4, IRQ5
Cable Length (max.)	1219 m (4000 ft)

6001-F2E Standard Driver

The Standard Driver allows the 1784-KR card to be used on the DH-485 communication network for data acquisition applications. This allows you to write 'C' application programs that communicate directly over the DH-485 network to stations such as the SLC 500. Non-token passing slave stations such as the 2755-DM6 Bar Code Reader are also supported.

Features

Provides a Set of Linkable 'C' Function Calls

Supports Microsoft 'C' v5.1 and Borland Turbo 'C' v2.0 Compilers

Provides application libraries

Benefits

Establishes communications with devices on the DH-485 network.

Eliminates the learning curve of new software packages.

Aids in data table read or write diagnostic commands.

1747-AIC Isolated Link Coupler for DH-485 Connection

The Isolated Link Coupler provides an electrically isolated network connection for an SLC 500 controller. One coupler is required at each DH-485 network drop. The coupler includes a 304.8 mm (12 in.) cable for connection to the programmable controller. Note that a maximum of 32 devices can be connected to the network.

Programming Options

The following section describes three types of programming options available for the SLC 500. The first is the 1747-PA2E Advanced Programming Software (APS), the second is the 1747-PT1 Hand-Held Terminal (HHT) that also requires the 1747-PTA1E memory pak, and the third is the SLC 500 A.I. Series programming software.

1747-PA2E Advanced Programming Software

The Advanced Programming Software (APS) v6.0 or later, enables you to program the SLC 500 family processors and the MicroLogix 1000 Programmable Controllers using the Allen-Bradley T47 or T70 terminal, 386/SX, NEC VERSA™ E Series Notebook, or GATEWAY 2000™ models 386DX/25, 386DX/33, 486DX/33, 486DX2/50, and 486DX2/66, or compatible personal computer.

Features

Full-line processor support

DH-485 and DF1 support

Data Highway Plus support (DH+)

Runtime online editing

Benefits

Programs any SLC 500 Fixed processor; SLC 5/01, SLC 5/02, SLC 5/03, and SLC 5/04 modular processors; and MicroLogix 1000.

Provides a variety of communication options to meet your application requirements.

Supports direct connection between the SLC 5/04 modular processor and DH+.

Allows entry of programs and data while online in the Run mode when using a SLC 5/03 or SLC 5/04 processor.

Features

Command line entry of instructions and parameters

Online context sensitive help

System auto configuration

Cut, copy, paste editor

Search and replace

APS Import/Export Utility (APSIE)

Benefits

Provides time saving keystrokes.

Provides quick access to instruction and status file information.

Automatically reads system configuration information (including I/O and chassis data), saving you valuable startup time.

Permits ladder logic to be re-used.

Allows quick modification of ladder logic to match unforeseen hardware changes.

Allows you to convert APS archive files and program documentation into ASCII text files and vice versa.

System Specifications

Description	Specification
Computer	Allen-Bradley T47 or T70 terminal, 386/SX, NEC VERSA™ E Series Notebook, or GATEWAY 2000E models 386DX/25, 386DX/33, 486DX/33, 486DX2/50, 486DX2/66, or compatible PC
Hardware	640 Kbytes of RAM (a minimum of 2 Mbytes of extended memory is required)
Operating System	DOS version 3.3 or higher
Printer Interface	parallel or serial 80, 132, or 255 columns

Refer to page 57 for the instruction set.

1747-PIC Interface Converter

The 1747-PIC Interface Converter changes RS-232 signal levels from your personal computer to RS-485 signal levels for the SLC 500 controller. The DH-485 protocol driver is provided by either the 1747-PA2E or 1747-PBASE software.

The converter includes an 279.4 mm (11 in) 25 pin ribbon cable for connection to the computer and a cable (Catalog Number 1746-C10) for connection to the SLC 500 controller.

1747-PT1 Hand-Held Terminal and 1747-PTA1E Programming Memory Pak

The Hand-Held Terminal (HHT) v2.03 is a powerful portable programming platform used to configure the SLC 500 Fixed, SLC 5/01, and the SLC 5/02 processors, enter or modify an application program, monitor the execution of the application program in real-time, or troubleshoot an application program. The HHT accepts programs with a maximum data table size of 6K. Each rung may contain up to 127 instructions. This differs from APS which has a maximum data table size of 16K and each rung can contain 128 instructions.

The programming memory pak is interchangeable and available in four languages. When used with the memory pak (v2.03), the HHT can be used to program the SLC 5/02 processor as well as connect to the DH-485 network. Note that the HHT does not support nested branching or conditional output branches.

Features	Benefits
Rugged construction	Designed for a variety of industrial environments.
Menu-driven firmware	Displays step-by-step directions.
LCD display	Shows up to five rungs of ladder logic at one time.
Network diagnostics	Checks the operation of the DH-485 network (v2.03).
ZOOM function	Displays detailed instruction information.
Formatted display	Displays PID and MSG instructions (v2.03).

Specifications

Description	Specification
Display	8 line x 40 character super-twist nematic LCD
Keyboard	30 keys
Operating Power	0.105A (max.) at 24 VDC
Communication	DH485
Environmental conditions	
Operating temperature	0 to +40° C (+32° to +104° F)
Storage temperature	-20° to +65° C (-4° to +149° F)
Humidity rating	5 to 95% (non-condensing)
Certification	UL listed, CSA approved

Refer to page 57 for the instruction set.

SLC 500 A.I. Series Programming Software

SLC 500 A.I. Series programming software is a DOS based, user-friendly, menu driven and function-key driven software package for programming the SLC 500 family processors using familiar ladder logic. The software package provides online and offline development, documentation and reporting capabilities.

The A.I. Series appeals to people who:

- develop complete ladder programs
- occasionally add or modify ladder rungs and data table values
- troubleshoot ladder programs

Software features enable the beginner to quickly become proficient in ladder logic development and documentation. The advanced user will find the software's powerful editing and diagnostic tools to be great time savers during ladder programming development and troubleshooting.

Features	Benefits
Online programming	Provides online and offline support for the SLC 5/03 and SLC 5/04 processors.
Symbolic programming	Allows you to use symbol names instead of addresses for programming
Automatic addressing	Helps manage data table and I/O usage information for you.
Cross Reference Information Display	Displays a listing of all instruction types, rung numbers, and program files for the highlighted address.
Custom display screens	Allows selection and display of 40 different addresses on a single screen
Advanced diagnostics	Allows user to select a section of ladder logic to displays rung numbers, output status and descriptions for troubleshooting.
Program compare	Detects differences between two projects.

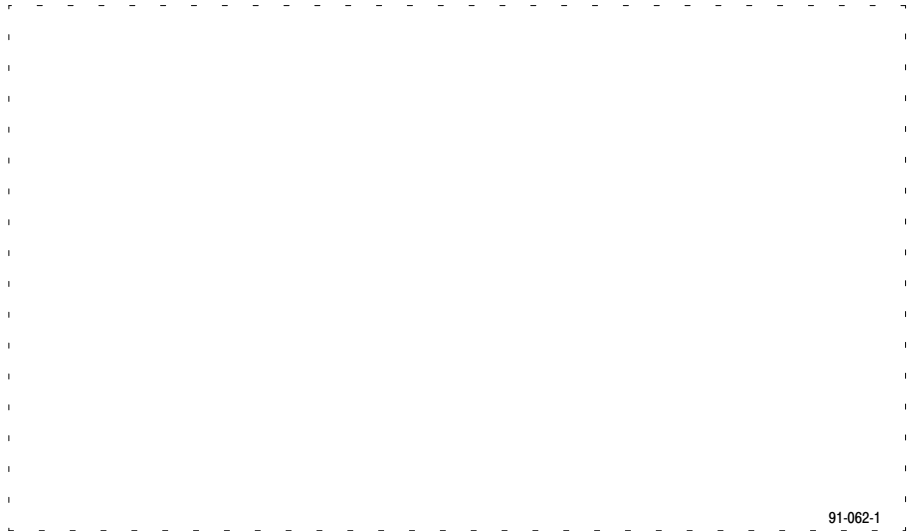

Operator Interface

Allen-Bradley recognizes the need for efficient interface products. The Data Table Access Module aids in accessing information and monitoring an SLC 500 control system at the plant floor level.

1747-DTAM-E Data Table Access Module

The Data Table Access Module (DTAM) is a plant floor device that allows you to access data file information, change operating modes, monitor and clear processor faults, and transfer memory from or to a EEPROM on any SLC 500, SLC 5/01, SLC 5/02, SLC 5/03, or SLC 5/04 processor. Multiple DTAMs can be connected to a single processor. Interactive messaging is also supported between the DTAM and the SLC 5/02, SLC 5/03, or SLC 5/04 processor. The DTAM provides the following features:

Features	Benefits
DH-485 network compatible	Communicates with up to 31 controllers, one at a time, up to 1219 m (4000 ft).
Data monitor or modify	Permits data values to be changed in the RUN or PROGRAM mode.
Quick recall macros	Stores frequently used address locations, saving time and simplifying application set-up and modification.
Auto-Attach mode	Automatically initiates communication with the last attached processor after a power cycle, saving costly down time and reducing keystrokes.

Features	Benefits
On-Board module configuration	Provides non-volatile EEPROM memory for easy onsite module set up.
Multilingual display	Selectable operator prompting in any of six languages.
Backlit LCD display	Allows for easy viewing in all lighting conditions.
Responds to MSG instructions	Allows interaction between the operator and the ladder program. The SLC 5/02, SLC 5/03, or SLC 5/04 processor ladder program directs the dialog.

Specifications

Description	Specification
Display	2 line x 16 character super-twist nematic LCD with LED backlighting
Keyboard	19 keys with tactile feedback
Operating Power	0.104 A (max.) at 24V dc
Communications	DH-485
Environmental conditions	
Operating temperature	0° C to +55° C (+32° F to +131° F)
Storage temperature	-20° C to +65° C (-4° F to +149° F)
Humidity rating	5 to 95% (non-condensing)
Certification	UL listed, CSA approved. Meets NEMA Type 12 and 13 enclosure applications.

Bulletin 2707 DTAM Plus Operator Interface

The DTAM Plus provides a highly functional operator interface to the SLC 500 family of processors. This device features a 4 line x 20 character display window for viewing SLC 500 data table information, operator prompts, and alarm data. The DTAM Plus uses the Allen-Bradley DH-485 network or a point-to-point link using RS-232 or DH-485. Refer to Publication 2707-2.0 for additional information.

Bulletin 2707 DTAM Micro

The DTAM Micro extends the DTAM Plus product line by providing another operator interface to the SLC 500 family of processors. DTAM Micro is a low cost operator interface and is physically smaller than the DTAM Plus. This device features a 2 line x 20 character display window for viewing data table information and operator prompts. Up to fifty application screens can be stored in memory.

DTAM Micro is available with either an RS-485 port or an RS-232 port. The RS-232 port is used to communicate point-to-point with the SLC 5/03. Use the RS-485 port to communicate point-to-point with the SLC processor or over the DH-485 network via Catalog 1747-AIC Isolated Link Couplers. The point-to-point connection allows for faster communication throughput and less DH-485 network loading.

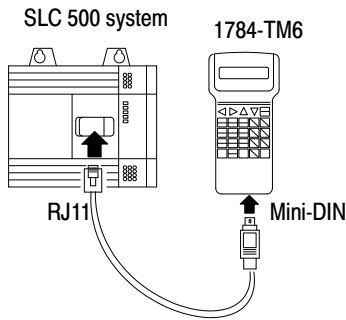

1784-TM6 I/O Monitor

The I/O Monitor is a hand-held device that allows you to view and modify data table information in an SLC 500 or PLC-5 programmable controller. You can display one file element, two words, or up to sixteen non-contiguous or contiguous bits. The I/O monitor allows you to search ladder programs for output addresses, change the processor mode, display fault information, and clear minor and major faults. Refer to Publication 1784-6.5.17 for additional information.

2711 PanelView Operator Terminals

The PanelView 550, 900, 1200, and 1400 Operator Terminals replace hard-wired control panels with CRT screens that are simple to configure. PanelView terminals provide you with extensive diagnostic information during fault conditions via message windows, alarm windows, and simple graphics. All four PanelView Operator Terminals easily connect to SLC 500 or PLC-5 systems allowing communication on the Remote I/O network.

The PanelView 550 Operator Terminal provides a high performance operator interface in a small, flat panel design. The flat panel LCD display has 256 x 128 pixel resolution. Field replaceable backlight extends the life of the terminal and maximizes system up time.

The PanelView 900 Operator Terminal provides a high performance operator interface in a small, flat panel design. The flat panel, AC gas plasma monochrome display has 640 x 400 pixel resolution that provides optimum viewability. The PanelView 900 Operator Terminal allows you to enter input using function keys or a touch screen.

With the DH-485 version, you can connect the PanelView 550 or PanelView 900 to a single SLC 500 processor or multiple SLC 500 processors on the DH-485 network. The PanelView 550 and PanelView 900 Operator Terminals support DH-485 point-to-point or network transfers.

With the RS-232 version, you connect directly to channel 0 of an SLC 5/03 or SLC 5/04 processor using DH485 protocol. This gives you dedicated DH485 connection for high priority data. The RS-232 channel supports passthru from the DH+ network to the PanelView 550 or PanelView 900 through channel 0 of an SLC 5/04 processor.

For additional information refer to Publication 2711-1.1.

Allen-Bradley Support

In today's competitive environment, when you buy any product, you expect that product to meet your needs. You also expect the manufacturer of that product to back it up with the kind of customer service and product support that will prove you made a wise purchase.

As the people who design, engineer, and manufacture your Industrial Automation Control equipment, Allen-Bradley has a vested interest in your complete satisfaction with our products and services.

Allen-Bradley offers support services worldwide, with over 75 Sales/Support Offices, 512 authorized Distributors and 260 authorized Systems Integrators located throughout the United States alone, plus Allen-Bradley representatives in every major country in the world.

Contact your local Allen-Bradley representative for:

- sales and order support
- product technical training
- warranty support
- support service agreements

User Documentation on CD-ROM

Improve productivity with quicker and easier access to product information. Volumes of Allen-Bradley product documentation are on the DataDisc™ CD-ROM Information Library (cat. nos. 1795-CDRS and 1795-CDRL). Use the search facility to locate all documentation instances of any item you specify. You can view and print the relevant pages.

Configuring an SLC 500 System

The following section describes:

- How to configure an SLC 500 chassis style system
- How to determine 1746 I/O module compatibility
- Available instructions used with the 1747-PA2E Advanced Programming Software and the 1746-PT1 Hand-Held Terminal
- Fixed controller wiring diagrams
- Dimensions for SLC 500 fixed and modular controllers, and compatible products

SLC 500 Chassis Configuration Instructions

This worksheet is intended to help you configure a modular style system. If a fixed I/O controller is more appropriate for your application, refer to page 8 of this System Overview. Each worksheet is designed to help you configure one chassis of I/O. If multiple chassis are necessary for your application, additional chassis should be configured using another worksheet.

1. Estimate the total amount of memory this system requires
 - a. Add up the number of discrete I/O points and place it in (a).
 - b. Add up the number of analog I/O points and place it in (b).
 - c. Add up the number of specialty I/O modules and place it in (c).
 - d. Multiply a, b, and c by the number indicated.
 - e. Total those numbers to give you a memory estimate.

2. Select a processor

Required Memory	Required I/O	Catalog Number
0 to 1K	Less than 256	1747-L511
1K to 4K	Less than 256	1747-L514
1K to 4K	Greater than 256	1747-L524
4K to 12K	Greater than 960	1747-L532
4K to 12K	Greater than 960	1747-L541
12K to 28K	Greater than 960	1747-L542
28K to 60K	Greater than 960	1747-L543

Place your choice into slot 0 of chassis 1 on the worksheet.

3. Select the I/O
 - a. If multiple chassis system, make copies for each chassis.
 - b. Write in the chassis number.
 - c. Write in the appropriate slot numbers.
 - d. Refer to pages 17 through 21 for discrete I/O selection.
 - e. Refer to pages 22 through 33 for specialty and analog I/O selection.
 - f. Using the worksheet, list each I/O module in the slot you desire.
 - g. List the power consumption of each module in the designated columns. Be sure to account for future expansion.
 - h. When the chassis is complete, add up each power consumption column.
4. Select the correct power supply
 - a. Compare the Power Consumption totals with each power supply.
 - b. Choose the smallest power supply that provides sufficient power. Note that the current shown is rated at 55° C (131° F).
5. Select the chassis
 - a. Add up the number of slots used.
 - b. Select the smallest chassis which can hold your I/O. Be sure to account for future expansion.
6. Select the miscellaneous devices
To complete your system, include devices such as:
 - Cables
 - Communication Interfaces
 - Operator Interface Devices
 - Memory Modules

SLC 500 Chassis Configuration Worksheet

1. To estimate your memory requirements, count the number of discrete and analog I/O points, plus the number of specialty I/O.

- a. discrete I/O points a) _____ x 10 = _____ Instruction Words
 - b. analog input and output points b) _____ x 25 = _____ Instruction Words
 - c. specialty I/O modules c) _____ x 100 = _____ Instruction Words
- Estimated Total Memory Required _____ Instruction Words

2. Select the Processor

- Catalog Number 1747-L511 SLC 5/01 1K Instructions
- Catalog Number 1747-L514 SLC 5/01 4K Instructions
- Catalog Number 1747-L524 SLC 5/02 4K Instructions
- Catalog Number 1747-L532 SLC 5/03 12K Instructions
- Catalog Number 1747-L541 SLC 5/04 12K Instructions
- Catalog Number 1747-L542 SLC 5/04 28K Instructions
- Catalog Number 1747-L543 SLC 5/04 60K Instructions

Power Consumption (Amps) ^①	
5V dc	24V dc
0.35	0.105
0.35	0.105
0.35	0.105
0.500	0.175
1.000	0.200
1.000	0.200
1.000	0.200

3. Select I/O

Chassis Number	_____	Catalog Number	Power Consumption		Price
			5V	24V	
Slot	_____	_____	_____	_____	_____
Slot	_____	_____	_____	_____	_____
Slot	_____	_____	_____	_____	_____
Slot	_____	_____	_____	_____	_____
Slot	_____	_____	_____	_____	_____
Slot	_____	_____	_____	_____	_____
Slot	_____	_____	_____	_____	_____
Slot	_____	_____	_____	_____	_____
Slot	_____	_____	_____	_____	_____
Slot	_____	_____	_____	_____	_____
Slot	_____	_____	_____	_____	_____
Slot	_____	_____	_____	_____	_____
Slot	_____	_____	_____	_____	_____
Slot	_____	_____	_____	_____	_____
Slot	_____	_____	_____	_____	_____

(Slot 0 Reserved for processor in chassis 1)

4. Select the Power Supply (shown at 55° C or 131° F)

	Total Current		
Catalog Number	2A	46A	_____
Catalog Number 1746-P1	5A	96A	_____
Catalog Number 1746-P2	3.6A	87A	_____
Catalog Number 1746-P3	10A	2.88A ^②	_____
Catalog Number 1746-P4			_____

5. Select the Chassis

- Catalog Number 1746-A4 4 slots _____
- Catalog Number 1746-A7 7 slots _____
- Catalog Number 1746-A10 10 slots _____
- Catalog Number 1746-A13 13 slots _____

6. Select Miscellaneous Devices

- _____
- _____
- _____
- _____

Total System Cost _____

^① Includes power requirements for the DTAM, PIC, and the HHT.

^② The combination of all output power (5 volt backplane, 24 volt backplane, and 24 volt user source) cannot exceed 70 Watts.

Fixed I/O Chassis Module Compatibility

You can use either of two methods to determine whether the 2-slot, fixed I/O expansion chassis will support a specific combination of modules.

- tabular method
- charting method

The table on the following page represents combinations of modules and indicates whether or not each combination is valid. The chart on page 56 represents the region of operating current that the fixed I/O expansion chassis supports.

Important: When referencing either method on the following pages, be aware that there are certain conditions that affect the compatibility characteristics of the BASIC module (**BAS**) and the DH-485/RS-232C module (**KE**).

When you use the BAS module or the KE module to supply power to a 1747-AIC Link Coupler, the Link Coupler draws its power through the module. The higher current drawn by the AIC at 24V dc is calculated and recorded in the tables for the modules identified as **BASn** (BAS networked) or **KE_n** (KE networked). Make sure to refer to these modules if your application uses the BAS or KE module in this way.

Tabular Method

Using the table on the next page, locate both of the modules you plan to use in the fixed I/O expansion chassis. Follow the top row across until you find one of the modules. Then follow the right column down until you find the other module. The symbol shown in the table cell that marks their intersection gives you information you must know before installing the modules.

- A dot indicates a valid combination.
- No symbol indicates an invalid combination.
- ▽ A triangle indicates an external 24V dc power supply may be required. (Refer to the Analog I/O Module User Manual, 1746-6.4.)

Charting Method

The following chart depicts the range of current combinations supported by the fixed I/O expansion chassis. To use it, you must first determine the backplane current draw and operating voltage for both of the modules you plan to use in the chassis. You can get these specifications from the table alongside the chart. Next, plot each of the currents on the chart below. If the point of intersection falls within the operating region, your combination is valid. If not, your combination cannot be used in a 2-slot, fixed I/O chassis.

	5VDC AMPS	24VDC AMPS
IA4	0.035	-
IA8	0.050	-
IA16	0.085	-
IM4	0.035	-
IM8	0.050	-
IM16	0.085	-
OA8	0.185	-
OA16	0.370	-
OAP12	0.370	-
IB8	0.050	-
IB16	0.085	-
IV8	0.050	-
IV16	0.085	-
IG16	0.140	-
OV8	0.135	-
OV16	0.270	-
OB8	0.135	-
OBP8	0.135	-
OG16	0.180	-
OW4	0.045	0.045
OW8	0.085	0.090
OW16	0.170	0.180
IO4	0.030	0.025
IO8	0.060	0.045
IO12	0.090	0.070
NI4	0.025	0.085
NIO4I	0.055	0.145
NIO4V	0.055	0.115
FIO4I	0.055	0.150
FIO4V	0.055	0.120
DCM	0.360	-
HS	0.300	-
OB16	0.280	-
IN16	0.085	-
BASn	0.150	0.125
BAS	0.150	0.040
OB32	0.452	-
OV32	0.452	-
IV32	0.106	-
IB32	0.106	-
OX8	0.085	0.090
NO4I	0.055	0.195
NO4V	0.055	0.145
ITB16	0.085	-
ITV16	0.085	-
IC16	0.085	-
KE	0.150	0.040
KE n	0.150	0.145
OBP16	0.250	-
OVP16	0.250	-
NT4	0.060	0.040
NR4	0.050	0.050
HSTP1	0.200	-

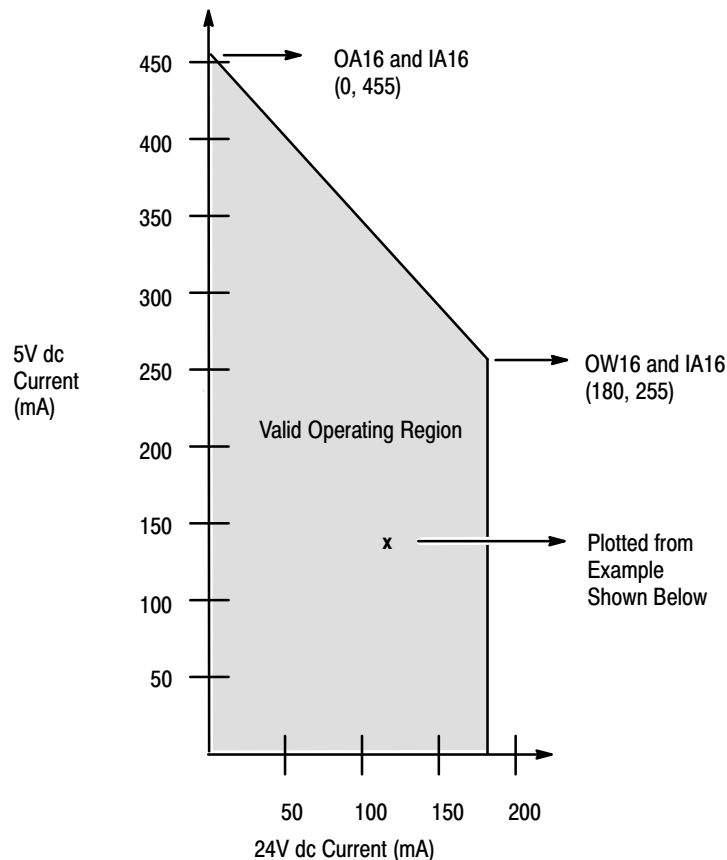

Example: Plot IN16 and NIO4V

IN16 = 0.085A at 5V dc

NIO4V = 0.055A at 5V dc and 0.115A at 24V dc

1. Add current draws of both modules at 5V dc to get 0.14A (140 mA).
2. Plot this point on the chart above (140 mA at 5V dc).
3. Plot current draw at 24V dc (115 mA at 24V dc).
4. Note the point of intersection on the chart above (marked x). This combination falls within the valid operating region for your fixed I/O chassis.

Important: The NO4I and NO4V analog output modules may require an external power supply. Refer to the analog user manual.

Instruction Set

Basic Instructions

Examine If Closed
 Examine If Open
 One Shot Rising
 Output Energize
 Output Latch
 Output Unlatch
 Timer On/Timer Off-Delay
 Retentive On-Delay Timer
 Count Up/Count Down
 High-Speed Counter
 Reset

I/O and Interrupt Instructions

I/O Interrupt Enable/Disable^①
 Reset Pending I/O Interrupt^①
 I/O Refresh^①
 Selectable Timed Enable/Disable^①
 Selectable Timed Start^①
 Interrupt Subroutine^①

Comparison Instructions^③

Equal
 Not Equal
 Less Than
 Greater Than
 Less Than or Equal
 Greater Than or Equal
 Masked Comparison for Equal
 Limit Test^①

Data Handling^③

Move
 Masked Move
 And
 Or
 Exclusive Or
 Not
 Convert to/from BCD
 Decode
 Load/Unload, First In First Out^①

Use the following instructions with your software or the HHT.

Load/Unload Last In First Out^①

Copy File

Fill File

Degrees to Radians^{②④}

Radians to Degrees^{②④}

Communication Instructions

Service Communications^①

Message^①

Math Instructions^③

Add/Subtract

Multiply/Divide

Double Divide

Clear

Negate

Square Root^①

Scale^①

Scale with Parameters^{②④}

Absolute^{②④}

Compute^{②④}

Swap^{②④}

Arc Sine^{②④}

Arc Cosine^{②④}

Arc Tangent^{②④}

Cosine^{②④}

Natural Log^{②④}

Log to Base 10^{②④}

Sine^{②④}

Tangent^{②④}

X to the Power of Y^{②④}

Program Flow Instructions

Label

Jump

Jump to Subroutine

Return from Subroutine

Master Control Reset

Temporary End

Suspend

Subroutine

^① Does not apply to the SLC 5/01 processor (Catalog Number 1747-L511 or 1747-L514) or the SLC 500 Fixed processor.

^② Applies only to SLC 5/03 (Catalog Number 1747-L532 OS302 or higher) and SLC 5/04 (Catalog Numbers 1747-L542, 1747-L542, and 1747-543 OS401 or higher) Processors.

^③ Only the SLC 5/03 (Catalog Number 1747-L532 or higher) and SLC 5/04 (Catalog Numbers 1747-L541, 1747-L542, and 1747-L543) processors support floating point math for these instructions.

^④ Does not apply to the HHT (catalog number 1747-PT1).

ASCII Instructions^{③④}

Test Buffer for Line

Number of Characters in Buffer

ASCII String to Integer

ASCII Clear Receive and/or Transmit Buffer

ASCII String Concatenate

ASCII String Extract

ASCII Handshake Lines

ASCII Integer to String

ASCII Read Characters

ASCII Read Line

ASCII String Search

ASCII String Compare

ASCII Write with Append

ASCII Write

Application Specific

Sequencer Output

Sequencer Compare

Sequencer Load^①

Bit Shift Right/Left

Special Instruction

Proportional, Integral, Derivative^①

Fixed Wiring Diagrams

For detailed wiring diagram information for the fixed controller, refer to the *Installation & Operation Manual for Fixed Hardware Style Programmable Controllers*, Catalog Number 1747-NI001.

CATALOG NUMBER 1747-L20A
(12) 120V ac Inputs & (8) Relay Outputs

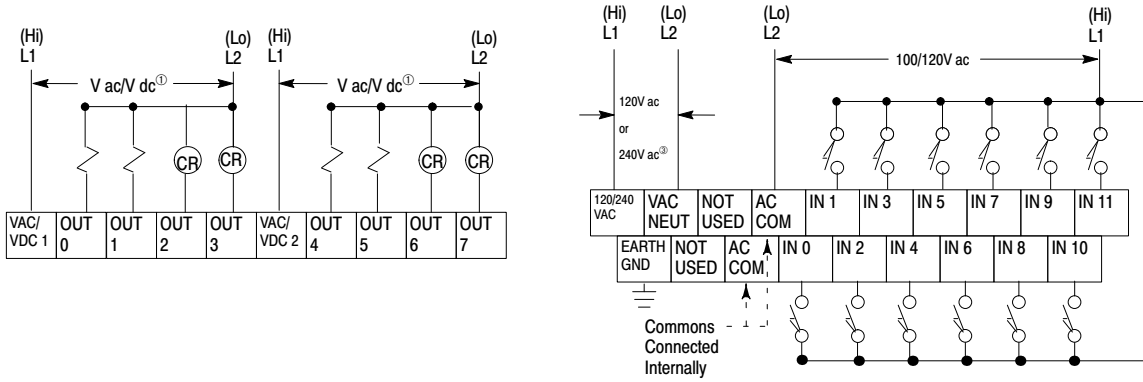

CATALOG NUMBER 1747-L20B
(12) 120V ac Inputs & (8) Triac Outputs

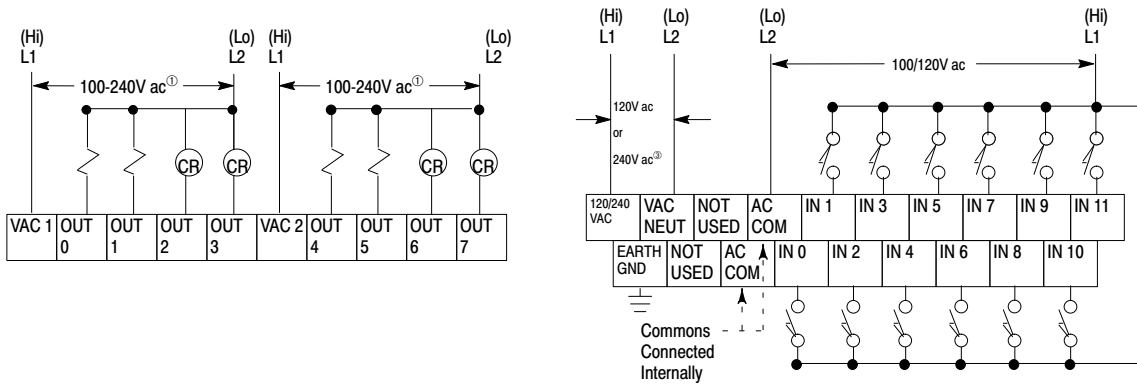

CATALOG NUMBER 1747-L20C
(12) 24 DC Volt Sinking Input Circuitry, High-Speed Counter Input & (8) Relay Outputs

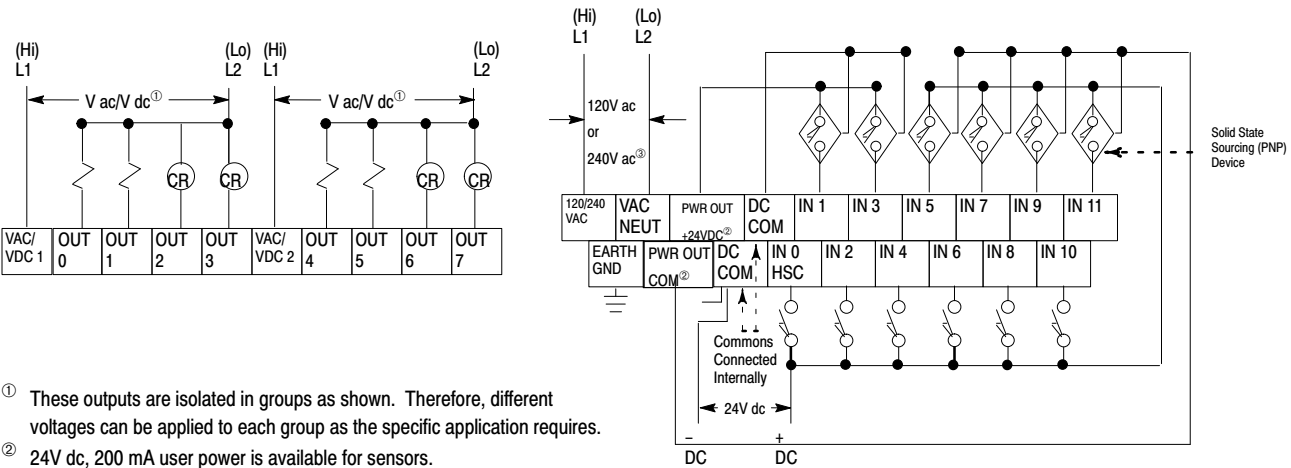

- ① These outputs are isolated in groups as shown. Therefore, different voltages can be applied to each group as the specific application requires.
- ② 24V dc, 200 mA user power is available for sensors.
- ③ 120 or 240 volt operation is automatically selected by the SLC processor.

CATALOG NUMBER 1747-L30A
 (18) 120 Volt AC Inputs & (12) Relay Outputs

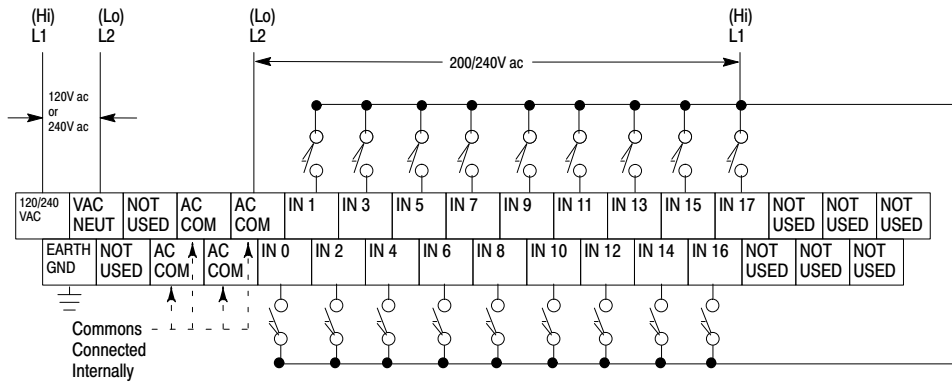
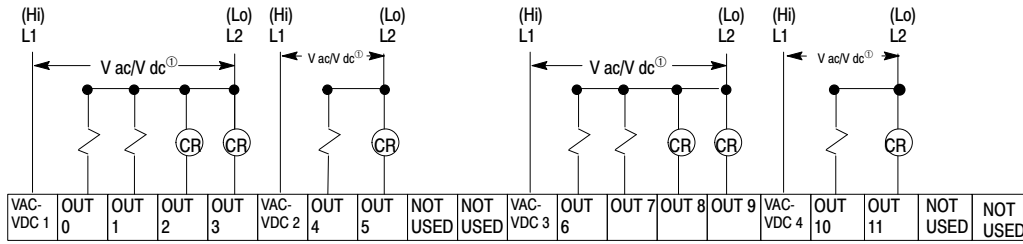

CATALOG NUMBER 1747-L40A
 (24) 120 Volt AC Inputs & (16) Relay Outputs

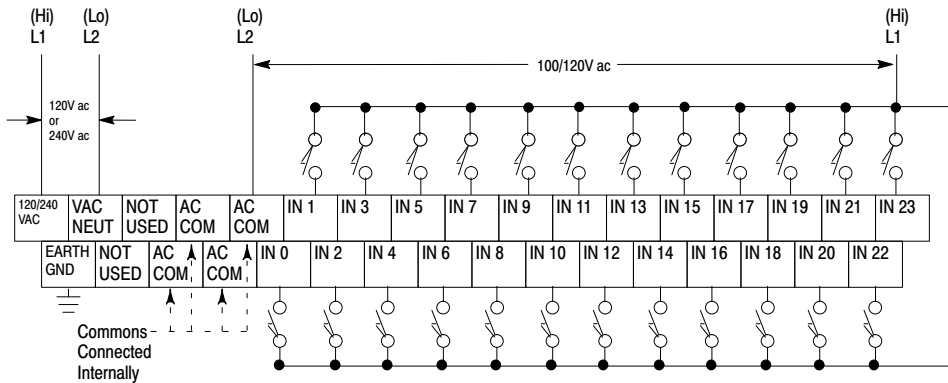
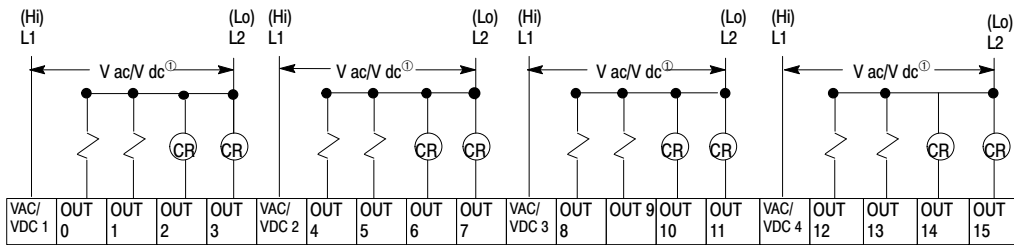

① These outputs are isolated in groups as shown. Therefore, different voltages can be applied to each group as the specific application requires.

Approximate Chassis Dimensions

millimeters (inches)

SLC 500 Fixed Controller

20 I/O Fixed Controller

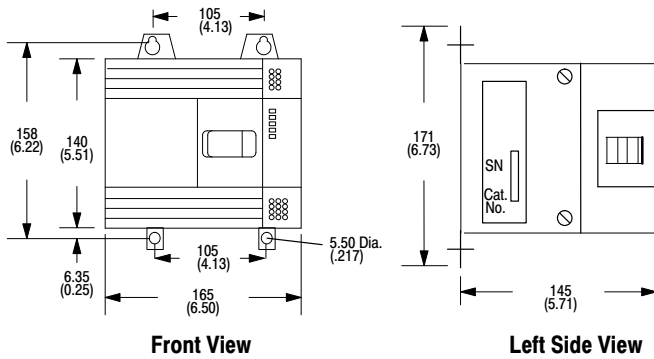

30 & 40 Fixed Controller

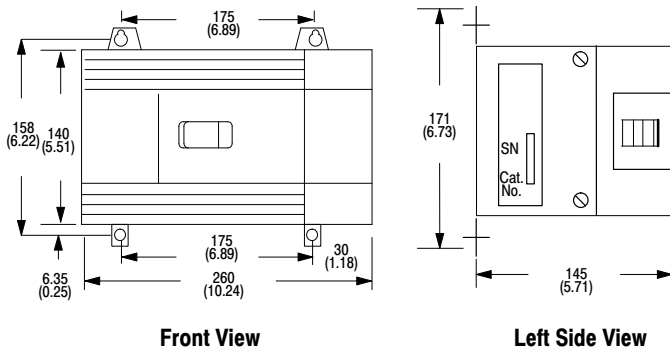

2-Slot Expansion Chassis

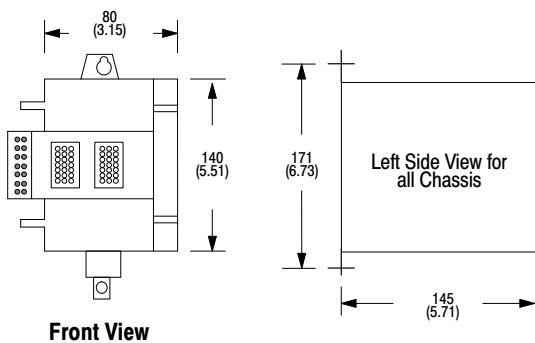

MicroLogix 1000 Controller

-L16BWA, -L16BBB, -L16BWB

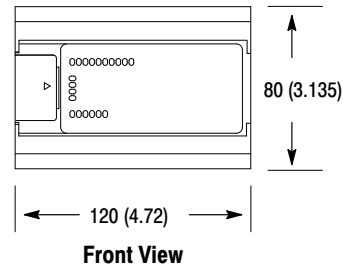

Front View

-L16AWA

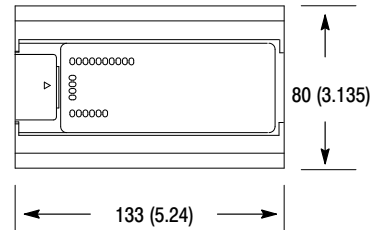

Front View

-L32AWA, -L32BWA, -L32AAA, -L32BBB, -L32BWB

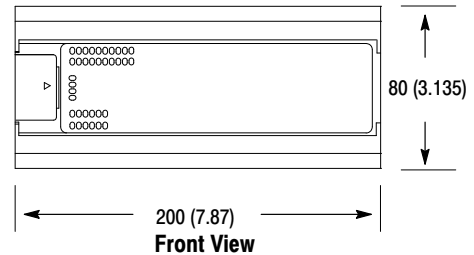

Front View

-L16AWA, -L16BWA, -L32AWA, -L32BWA, -L32AAA

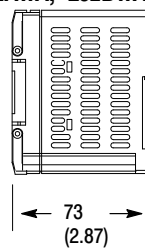

Side View

-L16BBB, -L16BWB, -L32BBB, -L32BWB

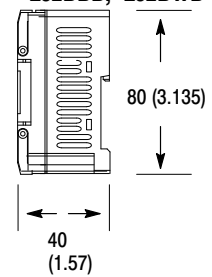

Side View

SLC 500 Modular Controller

4-Slot Chassis

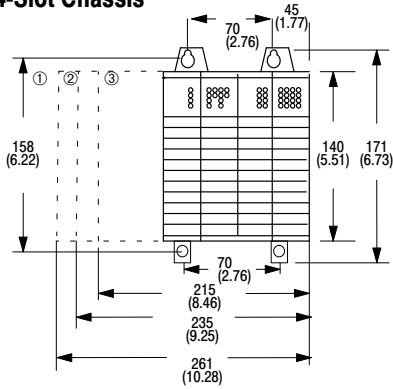

7-Slot Chassis

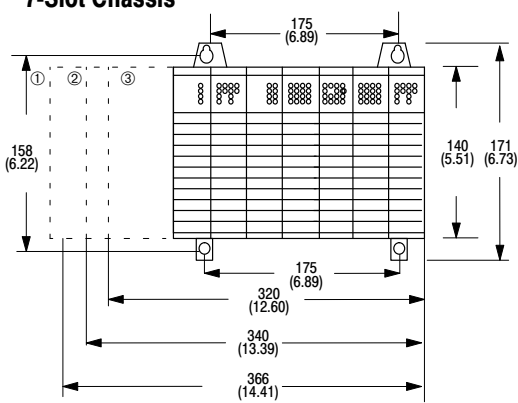

millimeters
(inches)

10-Slot Chassis

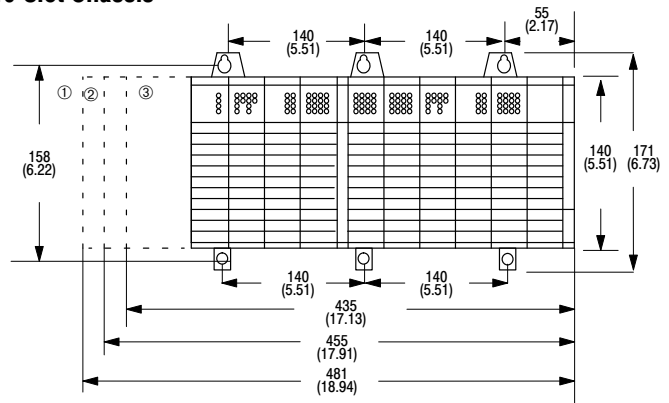

millimeters
(inches)

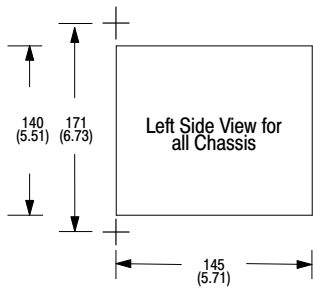

13-Slot Chassis

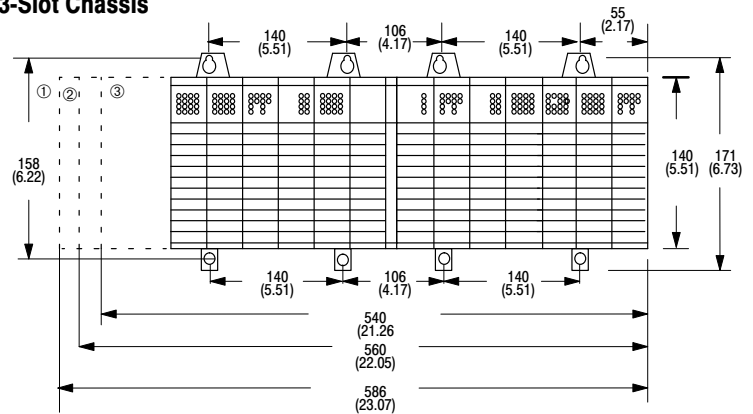

millimeters
(inches)

- ① Dimensions include the 1746-P4 power supply.
- ② Dimensions include the 1746-P2 and 1746-P3 power supplies.
- ③ Dimensions include the 1746-P1 power supply.

Data Table Access Module (DTAM, DTAM Plus, DTAM Micro)

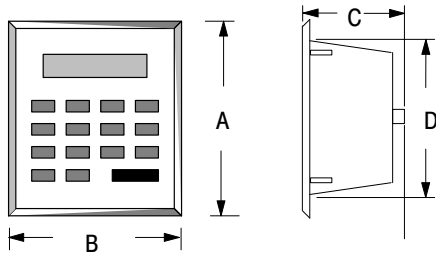

**millimeters
(inches)**

	A	B	C	D
DTAM	152 (6.0)	140 (5.5)	69 (2.76)	127 (5.0)
DTAM Plus	215.9 (8.5)	165.1 (6.5)	45.7 (1.8)	193 (7.6)
DTAM Micro	137.2 (5.4)	175.3 (6.9)	45.7 (1.8)	99.1 (3.9)

Isolated Link Coupler (AIC)

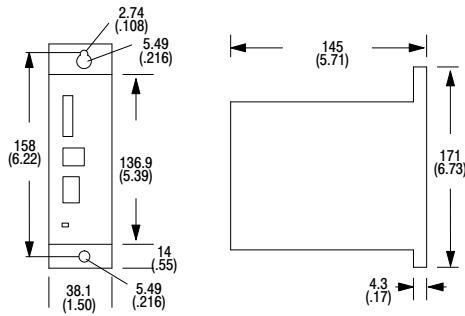

**millimeters
(inches)**

PanelView 550 Operator Terminal

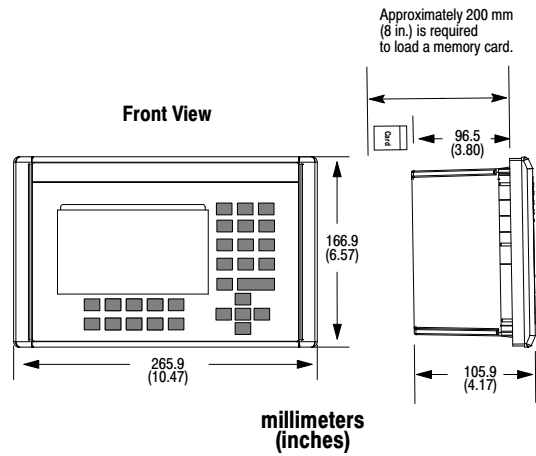

**millimeters
(inches)**

PanelView 900 Operator Terminal with Function Keys

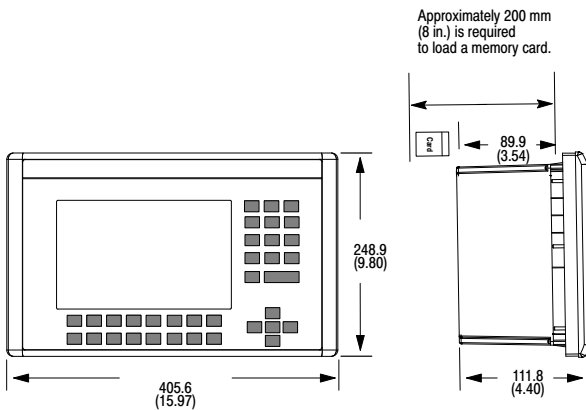

**millimeters
(inches)**



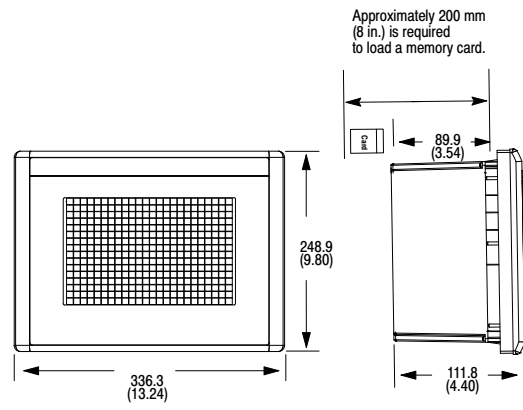







PanelView 900 Operator Terminal with Touch Screen



**millimeters
(inches)**

Available Cables

Use the following table to help you select the appropriate cable for your application.

For Connectivity Between These Devices		This is the Preferred Cable	These Cables May Be Used
1746-A4, -A7, -A10, or -A13 Chassis	 1746-A4, -A7, -A10, or -A13 Chassis	1746-C7 1746-C9	-
1747-PIC Personal Interface Converter 1747-PT1 Hand-Held Programming Terminal 1747-DTAM-E Data Table Access Module 2707-Lxxx, -Vxxx DTAM Plus	 1747-AIC Isolated Link Coupler SLC 500 Processors (DH-485 Channel)	1747-C10	1747-C11 1747-C20
1747-AIC Isolated Link Coupler	 SLC 500 Processors (DH-485 Channel)	1747-C11	1747-C10 1747-C13 1747-C20
1747-KE DH-485/RS-232C Interface Module 1746-BAS BASIC Module	 1747-AIC Isolated Link Coupler	1747-C13	1747-C11 1747-C10
1746-xx32 32-Point I/O Modules	 1492-IFM40x ^①	1492-CABLExH ^①	-
1747-L532 5/03 Processor (RS-232 Channel 0) 1747-L542 5/04 Processor (RS-232 Channel 0)	 Personal Computer Serial Port (9-Pin DTE)	1747-CP3	-
1746-I/O	 1492-IFMxx Interface Modules ^①	1492-CABLExx ^①	-
1747-SN Remote I/O Scanner 1747-DCM Direct Communications Module 1747-ASB SLC Remote I/O Adapter Module	 Remote I/O Network	Belden 9463	-
1747-AIC Isolated Link Coupler 1770-KF3 DH-485 Communication Interface 1784-KR Personal Computer Interface	 1747-AIC Isolated Link Coupler	Belden 9842	-
1761-L16AWA MicroLogix 1000 Controller 1761-L32AWA MicroLogix 1000 Controller 1761-L16BWA MicroLogix 1000 Controller 1761-L32BWA MicroLogix 1000 Controller 1761-L16BWB MicroLogix 1000 Controller 1761-L32BWB MicroLogix 1000 Controller 1761-L16BBB MicroLogix 1000 Controller 1761-L32BBB MicroLogix 1000 Controller	 IBM compatible PC	1761-CBL-PM02	-

^① For details, refer to the SLC 500 Price List, Publication 1746-3.0.

PLC and PLC-5 are registered trademarks of Allen-Bradley Company, Inc.
SLC, SLC 500, SLC 5/01, SLC 5/02, SLC 5/03, SLC 5/04, MicroLogix, IMC, PanelView, PanelBuilder, RediPANEL, Dataliner, DTAM, DataDisc, DeviceNet, DH+, and Data Highway Plus are trademarks of Allen-Bradley Company, Inc.
IBM is a registered trademark of International Business Machines Corporation.
Microsoft is a registered trademark of Microsoft.
Windows is a trademark of Microsoft.
VERSA is a trademark of Nippon Electric Company Information Systems, Inc.
Gateway 2000 is a trademark of Gateway 2000, Inc.
A.I. Series is a trademark of Rockwell Software Inc.



Allen-Bradley has been helping its customers improve productivity and quality for 90 years. A-B designs, manufactures and supports a broad range of control and automation products worldwide. They include logic processors, power and motion control devices, man-machine interfaces and sensors. Allen-Bradley is a subsidiary of Rockwell International, one of the world's leading technology companies.

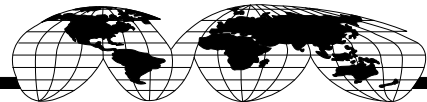

With major offices worldwide.

Algeria • Argentina • Australia • Austria • Bahrain • Belgium • Brazil • Bulgaria • Canada • Chile • China, PRC • Colombia • Costa Rica • Croatia • Cyprus • Czech Republic • Denmark • Ecuador • Egypt • El Salvador • Finland • France • Germany • Greece • Guatemala • Honduras • Hong Kong • Hungary • Iceland • India • Indonesia • Israel • Italy • Jamaica • Japan • Jordan • Korea • Kuwait • Lebanon • Malaysia • Mexico • New Zealand • Norway • Oman • Pakistan • Peru • Philippines • Poland • Portugal • Puerto Rico • Qatar • Romania • Russia-CIS • Saudi Arabia • Singapore • Slovakia • Slovenia • South Africa, Republic • Spain • Switzerland • Taiwan • Thailand • The Netherlands • Turkey • United Arab Emirates • United Kingdom • United States • Uruguay • Venezuela • Yugoslavia

World Headquarters, Allen-Bradley, 1201 South Second Street, Milwaukee, WI 53204 USA, Tel: (1) 414 382-2000 Fax: (1) 414 382-4444