

9000 Series Sensor Installation Guide

**Your Guide to Permanent
9000 Series Sensor Installation**

Rockwell Automation Entek

P/N 48204

Copyright Notice

Copyright © 2003 by Entek IRD International Corporation

All Rights Reserved
Second Edition 2003
Printed in the U.S.A.

This Manual is supplied to the User under license, subject to recall by Entek IRD International Corporation at any time, and the Manual at all times remains the property of Entek IRD International Corporation. The information contained in this Manual is considered confidential. No part of this Manual is to be copied or reproduced or transmitted in any form whatever (including orally or by electronic transmission), nor is any information in this Manual to be disclosed in any form whatever (including orally or by electronic transmission) to anyone other than an authorized representative of the User's employer who also shall agree not to disclose same, without express prior written consent of Entek IRD International Corporation.

Trademarks

Entek, IRD, and Entrx are registered trademarks, and enwatch and XM are trademarks of Entek IRD International Corporation, a Rockwell Automation company.
All other product names are registered trademarks of their respective owners.

Contacting Rockwell Automation Entek
Technical Support Telephone—1-800-368-3547
Technical Support Fax—1-513-576-4213
World Wide Web—www.rockwellautomation.com

Table of Contents

Introduction	1
9000 Series Sensors	1
Sensor Mounting	5
Types of Sensor Mounting	5
Mounting sensors directly on the case	5
Mounting sensors on an insulated housing	6
Mounting sensors with adhesive	7
Mounting sensors with a bracket	8
Sensor Cable Guidelines	9
Sensor Connections and Power	9
Cable Installation	10
Cable length	11
Reducing electrical interference	12
Cable construction	13
Splicing cables	14
Cable Conduit Guidelines	14
Cables in conduit	14
Conduit runs to panels	14
Conduit boxes	14
Connecting 9000 Series Sensors to Monitors	15
Index	21

Table of Contents

**ENTEK IRD INTERNATIONAL CORPORATION
GENERAL TERMS AND CONDITIONS**

- 1. CONTRACT.** When Customer accepts a Quotation from Entek IRD International Corporation or an affiliate (the entity issuing the quotation being “Entek IRD”) by issuance of a purchase order or otherwise and Entek IRD accepts the order, Customer is deemed to have agreed to all the Terms and Conditions contained herein. Unless otherwise approved in writing, the acceptance of Entek IRD is expressly conditioned upon Customer accepting these Terms and Conditions, and any different or additional terms and conditions contained in Customer's order or related documents are expressly objected to by Entek IRD and not binding upon it. Entek IRD reserves the right to accept or reject all orders received by it and all orders may only be accepted at the contracting office of Entek IRD located in Ohio. Entek IRD may accept in writing, by commencement of performance or otherwise.
- 2. QUOTATIONS.** All quotations expire automatically thirty days from date of quotation or earlier by notice from Entek IRD. Unless otherwise noted in writing by Entek IRD, all prices are F.O.B. the place of origin for domestic shipments and Ex Works (as defined in INCOTERMS 1990) for international shipments; and risk of loss in transit is on Customer. Prices do not include any applicable taxes, however designated, levied or based upon the goods or services being quoted. Customer agrees to pay all such taxes or provide acceptable evidence of exemption therefrom.
- 3. TIMING.** All delivery/shipping and service dates stated by Entek IRD are approximate dates only and estimated in good faith to the best of Entek IRD's ability and are dependent upon Entek IRD's prompt receipt of all necessary information from Customer. Time shall not be deemed to be of the essence in Entek IRD's performance of this agreement, and no penalty clause of any description in any specification or order will be effective unless specifically approved in writing by an authorized officer of Entek IRD. In any event delivery/shipping and service dates are always quoted subject to unavoidable delays due to causes beyond Entek IRD's control including but not limited to strikes, casualty, war, acts of God, or government action.
- 4. TERMS.** Payment terms for domestic orders are net 10 days from date of invoice, unless otherwise provided in the quotation. For international orders, Entek IRD reserves the right to specify prepayment, letter of credit, or payment net 10 days from the date of invoice. Each shipment shall be considered a separate and independent transaction and payment must be made accordingly. If the financial condition or credit of Customer at any time in the judgment of Entek IRD, does not warrant shipment of goods ordered, Entek IRD may at its option require full payment prior to shipment or refuse to ship and terminate any order outstanding without liability to Entek IRD. Should Customer become delinquent in the payment of any sum due, Entek IRD shall not be obligated to continue performance. If any amount is not paid when due, to the extent permitted by law a late fee of 1% per month (or any part thereof) shall be charged on past due amounts until paid.
- 5. CANCELLATION.** Once accepted by Entek IRD, an order is not subject to cancellation in whole or in part by Customer without Entek IRD's prior written consent. Any such cancellation shall be subject to a cancellation charge as determined by Entek IRD to cover any loss that may be incurred by Entek IRD as a result of such cancellation, including without limitation a 25% restocking charge for standard products.

6. **CUSTOMER RESPONSIBILITIES.** Customer shall be solely responsible for the accuracy and adequacy of the information provided to Entek IRD, and Entek IRD shall not be liable for any damages resulting from the loss, disclosure or inaccuracy of such information. Customer shall, for those contracts which include on site installation, have the installation site prepared at its expense prior to the scheduled installation date to enable Entek IRD to promptly deliver and commence installation. The equipment is not for use in or with any nuclear facility, unless the Quotation expressly permits such use; and Customer shall indemnify and hold Entek IRD harmless from all liability (including such liability resulting from Entek IRD's negligence) arising out of such improper use. Customer shall not send or use the products outside the United States except in compliance with all applicable law, including U.S. export regulations and restrictions.
7. **SOFTWARE AND SERVICES DOCUMENTS.** If any computer software, whether incorporated into a piece of equipment ("firmware"), or provided separately, and related user documentation in any medium (together referred to as "Software") are included in the contract, the terms of the Entek IRD Standard Software License Agreement shall govern the contract with respect to Software. If any services are included in the contract, the Entek IRD Standard Field Engineering Services Terms and Conditions shall govern such services. Those documents are available to Customer upon request, and Customer is responsible to obtain and read the Standard Software License Agreement and the Standard Field Engineering Services Terms and Conditions.
8. **LIMITED WARRANTIES AND REMEDIES.**
 - A. Entek IRD warrants to Customer (and not anyone else) that all equipment manufactured by Entek IRD shall be free of defects in materials and workmanship under normal conditions for a period of one (1) year from the date of shipment (except that items with limited life such as batteries and lamps are warranted for 90 days from date of shipment).
 - B. With respect to any Entek equipment which fails to satisfy the limited warranty provisions in this Section, as Customer's exclusive remedy, and at Entek IRD's option, Entek IRD will repair or replace the product or refund its purchase price, provided that any defect in the product is brought to the attention of Entek IRD within the warranty period. To qualify for this warranty Customer must return the defective product to Entek IRD's designated facility freight prepaid, and after repair or replacement Entek IRD will return the product freight prepaid; or, if in Entek IRD's opinion the product is impractical to ship, Customer shall be charged for labor, transportation and subsistence expenses for the service representative(s) providing the warranty work at Customer's site. Entek IRD alone will be authorized to furnish or arrange for repairs or replacements.
 - C. The above limited warranties do not apply, and no warranty, either express or implied, shall be applicable, (a) to damage resulting from accident, alteration, misuse or abuse, harmful conditions or Act of God; (b) if the product is not installed, operated and maintained according to procedures recommended by Entek IRD; or (c) if the Entek IRD serial number is obliterated. In no case shall the limited warranty extend to defects in materials, components, or services furnished by third parties or to the repair or installation of the product performed by third parties. The above warranties do not extend to any equipment sold "as-is" or "as-inspected;" no warranties, either express or implied, are made with respect to such products.
 - D. Entek IRD makes no representations or warranties to Customer, or anyone else, with respect to equipment manufactured by a third party. Any warranties of the third party manufacturers shall run directly to Customer to the extent permitted by law and Entek IRD shall have no liability therefor.
 - E. The limited warranties in this Section constitute Entek IRD's entire warranty as to the products provided hereunder. ENTEK IRD HEREBY DISCLAIMS ALL OTHER WARRANTIES, EXPRESS OR IMPLIED, INCLUDING CONFORMITY TO ANY REPRESENTATION OR DESCRIPTION AND INCLUDING IMPLIED WARRANTIES OF MERCHANTABILITY AND FITNESS FOR ANY PARTICULAR PURPOSES WHATSOEVER.

- 9. EXCLUSIVE REMEDIES AND LIABILITY LIMITATION.** THE REMEDIES PROVIDED HEREIN ARE CUSTOMER'S SOLE AND EXCLUSIVE REMEDIES, AND ENTEK IRD'S EXCLUSIVE LIABILITY WHETHER ARISING IN CONTRACT, TORT (INCLUDING NEGLIGENCE), STRICT LIABILITY OR ANY OTHER LEGAL THEORY. CUSTOMER AGREES THAT NO OTHER REMEDY (INCLUDING, BUT NOT LIMITED TO, INCIDENTAL OR CONSEQUENTIAL DAMAGES, LOST PROFITS, LOST SALES, LOST PRODUCTION, OVERHEAD, LABOR, INJURY TO PERSON OR PROPERTY, OR ANY OTHER INCIDENTAL LOSS) SHALL BE AVAILABLE TO CUSTOMER. THIS ALLOCATION OF RISK IS REFLECTED IN THE PRICES OF THE PRODUCTS. ENTEK IRD'S MAXIMUM LIABILITY HEREUNDER ARISING FROM ANY CAUSE WHATSOEVER SHALL BE LIMITED TO THE PURCHASE PRICE OF THE PRODUCTS IN QUESTION. Any suit related to this Agreement, on any legal theory, must be commenced within one year after the cause of action accrues.
- 10. TITLE AND LIEN RIGHTS.** The equipment shall remain personal property regardless of how it is affixed to Customer's real property and Entek IRD reserves a purchase money security interest in the equipment until the purchase price has been fully paid. Customer agrees to execute, and hereby appoints Entek IRD as its attorney-in-fact to execute on Customer's behalf, any documents requested by Entek IRD which are necessary for attachment and perfection of its security interest. If Customer defaults, Entek IRD shall have all the rights of a secured creditor under the Uniform Commercial Code as enacted in Ohio.
- 11. OTHER TERMS.** These terms and conditions and any issue, claim or dispute arising hereunder shall be interpreted under and governed in all respects by the internal laws of the State of Ohio, and not by the 1980 U.N. Convention on the International Sale of Goods. These terms and conditions and the written quotation to which they relate constitute the entire contract between the parties, and supersede all other oral or written statements of any kind whatsoever made by the parties or their representatives. Waiver by Entek IRD of strict compliance with any one or more of these Terms and Conditions is not to be considered a continuing waiver or a waiver of any other term or condition. No statement purporting to modify any of these terms or conditions shall be binding unless expressly agreed to in writing signed by an officer of Entek IRD and by Customer.

9000 Series Sensor Installation

This manual shows you how to install the 9000 series sensors. It is intended for anyone who installs or maintains a predictive maintenance system with permanently mounted sensors.

Introduction

A sensor (also called a transducer) is a device that measures a physical quantity and converts it into a proportional electrical signal, typically voltage or current. This signal is sent through a cable to a central monitoring station. There the signal is converted into a measurement with meaningful units. For example, the voltage signal from an accelerometer is converted into a measurement with units of acceleration.

In order for a sensor to function correctly and accurately, several things must be true:

- It must be mounted correctly. For an accelerometer, the best method is to bolt or stud mount the sensor at the correct location on the machine. Adhesive mounting is a suitable option when stud mounting is not feasible.
- The cable must be able to carry the signal without degrading the signal at the frequencies of interest over the length of the cable.
- The cable must be correctly connected to the monitoring device. In some cases, this is a station where the signal may be processed and tested against one or more alarm setpoints. In addition, the monitoring device may convert the signal for transmission over a network. Monitoring devices include data collectors, Enwatch™ units, 6600 Series Protection Monitors, XM™ series, Entrx®, and other vibration analysis systems.
- Proper grounding techniques must be observed at all times, and particularly when running a cable through a junction box.

This manual covers sensors, permanent mounting, and cable installation. Refer to the specific monitoring device manual for information about connecting the sensor signal to the monitoring device.

9000 Series Sensors

The 9000 series accelerometers cover a wide range of applications including low frequency (less than 0.1 Hz or 6 CPM), high frequency (up to 30 kHz or 1500 kCPM), high temperature (over 250° C), and velocity output (internal integrator). The following table lists the sensors and characteristics.

Model Number	Part No	Bias Output	Sensitivity	Description	Notes
General Purpose					
9000A	43781I	8–12 VDC	100 mV/g	General purpose accelerometer	Top exit, Mil Spec connector.
9000A-LBV	43783I	6–8 VDC	100 mV/g	General purpose accelerometer	Top exit, Mil Spec connector. Low bias voltage (6–8 V).
9000B	43782I	8–12 VDC	100 mV/g	General purpose accelerometer	Top exit, integral cable 10', 2-conductor shielded, polyurethane jacket.
9008	46255I	8–12 VDC	100 mV/g	Low cost general purpose accelerometer	Top exit, integral cable 10', 2-conductor shielded, polyurethane jacket.
9100	43784I	8–12 VDC	100 mV/g	General purpose precision accelerometer	Top exit, Mil Spec connector.
9100AT	43810I	8–12 VDC	100 mV/g 10 mV/°C	General purpose precision accelerometer, temperature sensor	Top exit, Mil Spec connector.
9100CSA	43786I	8–12 VDC	100 mV/g	General purpose precision accelerometer	Top exit, Mil Spec connector. Intrinsic Safety Certification by Canadian Standards Association.
9100EX	43787I	8–12 VDC	100 mV/g	General purpose precision accelerometer	Top exit, Mil Spec connector. Intrinsic Safety Certification to CENELEC EEx ia iic T4.
9100FM	43785I	8–12 VDC	100 mV/g	General purpose precision accelerometer	Top exit, Mil Spec connector. Intrinsic Safety Certification by Factory Mutual.
9200	47086I	8–12 VDC	100 mV/g	General purpose, precision low profile ring style accelerometer	Side exit, Mil Spec connector.
9200AT	43811I	8–12 VDC	100 mV/g 10 mV/°C	General purpose, precision low profile ring style accelerometer, temperature sensor	Side exit, Mil Spec connector.
9200CSA	43790I	8–12 VDC	100 mV/g	General purpose, precision low profile ring style accelerometer	Side exit, Mil Spec connector. Intrinsic Safety Certification by Canadian Standards Association.
9200EX	43791	8–12 VDC	100 mV/g	General purpose precision accelerometer	Side exit, Mil Spec connector. Intrinsic Safety Certification to CENELEC EEx ia iic T4.

Model Number	Part No	Bias Output	Sensitivity	Description	Notes
9200FM	43789I	8–12 VDC	100 mV/g	General purpose, precision low profile ring style accelerometer	Side exit, Mil Spec connector. Intrinsic Safety Certification by Factory Mutual.
9300	43792I	8–12 VDC	100 mV/g	Low cost accelerometer	Top exit, Mil Spec connector.
9400	47090I	8–12 VDC	100 mV/g	General purpose, low profile side exit accelerometer	Side exit, Mil Spec connector.
Low Frequency					
9100L	43794I	8–12 VDC	500 mV/g	Low frequency accelerometer	Top exit, Mil Spec connector.
9200L	43795I	8–12 VDC	500 mV/g	Low frequency, low profile ring style accelerometer	Side exit, Mil Spec connector.
9500LF	43796I	6–9 VDC	500 mV/g	Low frequency accelerometer	Top exit, Mil Spec connector.
9500HLF	43797I	8–12 VDC	1000 mV/g	Low frequency accelerometer	Top exit, Mil Spec connector.
9600	43798I	8–12 VDC	10 V/g	Ultra low frequency accelerometer	Top exit, Mil Spec connector.
High Frequency					
9700A	43799I	8–12 VDC	10 mV/g	High frequency accelerometer	Top exit, 5-44 microdot connector.
9700B	43800I	8–12 VDC	100 mV/g	High frequency accelerometer	Side exit, 10-32 coaxial connector.
Triaxial					
9900A	43802I	8–12 VDC	100 mV/g	Triaxial accelerometer with positioning pin	Side exit, Mil Spec 4-pin connector.
9900B	43803I	8–12 VDC	100 mV/g	Triaxial accelerometer with positioning pin	Side exit, integral cable 10', 4-conductor shielded, polyurethane jacket.

Model Number	Part No	Bias Output	Sensitivity	Description	Notes
High Temperature					
9100T	43805I	8–14 VDC	100 mV/g	High temperature accelerometer	Top exit, Mil Spec connector, -54 to 163 deg C operating range.
9150HT	43807I	12–15 VDC	100 mV/g	High temperature charge mode accelerometer system	Top exit, 2-Pin Mil Spec connector, -54 to 260 deg C operating range.
9150HTA	46496	12–15 VDC	100 mV/g	High temperature charge mode accelerometer system	Top exit, 2-Pin Mil Spec connector, -54 to 260 deg C operating range. Armored cable.
9200T	43806I	11–14 VDC	100 mV/g	High temperature, low profile ring style accelerometer	Side exit, Mil Spec connector, -54 to 163 deg C operating range.
Velocity Output					
9100VO	43808I	8–12 VDC	100 mV/in/sec	Velocity output accelerometer	Top exit, Mil Spec connector.
9200VO	43809I	8–12 VDC	100 mV/in/sec	Velocity output, low profile ring style accelerometer	Side exit, Mil Spec connector.

Sensor Mounting

Next to choosing the correct sensor, the sensor mounting is the most important consideration in getting accurate readings from the sensor.

Types of Sensor Mounting

The actual frequency range of a sensor depends on how well it is attached to the machine.

Mounting sensors directly on the case

Mounting sensors directly to the machine is the most common mounting technique for many vibration sensors. Sensors designed for stud mounting have a base that is drilled and tapped for that purpose. There are two common methods of stud mounting a sensor. In both cases, it is crucial to prepare a flat, smooth, and clean area at least as large as the base of the sensor. If the surface is not prepared properly, some of the vibration energy will be lost, and will not be transmitted to the sensor. Improper mounting can also allow chatter, creating false data.

Note: Entek recommends following the API 670 requirements for surface finish and flatness, even for non-API installations. If the surface is not properly prepared, it can reduce the detection of higher frequencies.

1. The first method is to spot face the surface, then drill and tap a hole in the machine case or bearing housing where you want to install the sensor. Per the requirements of API 670 Appendix C.2.1, the surface finish should be within 0.8 micrometers (.032 mil, or 32 μ inches) and the flatness should be below 25 micrometers (1 mil).
2. Clean the finished area to remove any rust, dirt, paint, or grease.
3. Insert a set screw leaving enough of the screw above the case to attach the sensor, typically 1/4 inch. Some sensors come with captive mounting screw and do not need a separate set screw.
4. Apply a thin coating of grease or silicone lubricant to the surface.
5. Use a torque wrench to attach the sensor. Refer to the following table.

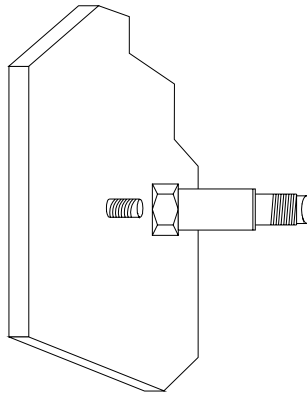

Follow the specific sensor’s guidelines for the dimensions of the hole, the type of set screw, and the torque for attaching the sensor. The table below lists the data for the 9000 sensors.

Sensor	Screw Type	Hole Depth	Torque
9100 Series	1/4-28 stud	3/8 inch	26 inch-pounds
9200 Series	1/4-28 captive screw	3/8 inch	30 inch-pounds
9300 Series	1/4-28 stud	3/8 inch	26 inch-pounds
9400 Series	1/4-28 captive screw	3/8 inch	30 inch-pounds
9500 Series	1/4-28 stud	3/8 inch	26 inch-pounds
9600 Series	3/8-16 stud	1/2 inch	60 inch-pounds
9700A	5-40 stud	3/8 inch	12 inch-pounds
9700B	10-32 stud	3/8 inch	20 inch-pound

Note: For 3/8 deep holes, make sure 1/4 inch of the stud engages the base of the sensor. If you screw a 1/2 inch stud fully into a 3/8 inch deep hole, that leaves only 1/8 inch of stud to hold the sensor, which is not sufficient.

The second method is to drill through the machine case or housing, and use a machine screw to secure the sensor. Spot face the surface, then drill the hole in the machine case or bearing housing where you want to install the sensor. Follow the sensor’s guidelines for the dimensions of the hole, the type of machine screw, and the torque for attaching the sensor.

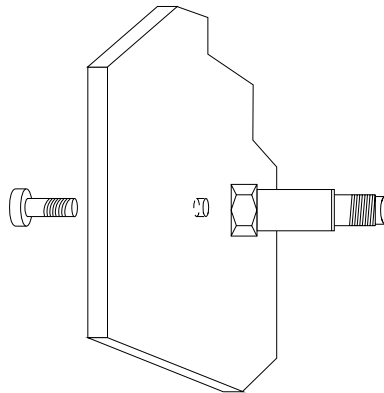

Mounting sensors on an insulated housing

In some cases, the sensor is mounted on an insulated housing that cannot or should not be grounded. For this type of installation, we recommend that you use a sensor with a ground-isolated case. Many of the 9000 Series sensors have ground-isolated cases. Note that the 9700 does not have isolated case. The 9700B and 9150HT are base isolated, not case isolated. Contact Rockwell Automation Integration Condition Monitoring Technical Support for more information on the Entek sensors.

When connecting cables for sensors with ground-isolated cases, make sure that the cable shield is not grounded at the sensor end. There are two possible cable configurations:

- In coaxial cable, the center conductor carries the signal and power, while the outer braid provides shielding and signal return. Grounding the shield at the monitoring device and not at the sensor isolates the sensor and prevents ground loops.
- In cable with two wires and shield, the signal and power are carried on one lead and the signal return on the other lead. The outer braid provides shielding. To isolate the sensor and prevent ground loops, ground the shield at the monitoring device.

Note: It is very important to properly ground the cable shield. Failing to do so can result in interference with the signal and possible damage to the sensor in high electromagnetic interference/electrostatic discharge environments.

Mounting sensors with adhesive

If a mounting hole cannot be drilled into the machine surface, you can mount the sensor using adhesive. There are two ways to do this: you can mount the sensor directly to the machine; or you can mount a flat plate with a threaded stud, and attach the sensor to the stud. Note that mounting the sensor using adhesive may limit the detection of high frequencies. Suggested adhesives are listed in the following table.

Adhesive	Comments
Loctite 325 with 707 Activator	Cyanoacrylate adhesive. Single component; sets up quickly; use at temperatures below 200° F; surface must be clean and smooth, and remove by twisting the sensor.
Versilok 406–Lord Chemical Products	Structural adhesive. Water resistant; useful to 250° F; cures to full properties at room temperature in 24 hours.

Note: Entek recommends following the API 670 requirements for surface finish and flatness, even for non-API installations. If the surface is not properly prepared, it can reduce the detection of higher frequencies.

1. Spot face the surface on the machine case or bearing housing where you want to install the sensor. Per the requirements of API 670 Appendix C.2.1, the surface finish should be within 0.8 micrometers (.032 mil, or 32 μinches) and the flatness should be below 25 micrometers (1 mil).
2. Prepare the surface following standard adhesive bonding practice. Abrade and then thoroughly clean the spot on the machine with solvent.
3. Mix the adhesive according to its directions.
4. Attach the sensor or plate to the machine.
5. Allow the recommended time for the adhesive to cure.
6. Make sure the sensor is grounded through the cable shield to a good electrical ground.

Mounting sensors with a bracket

Sometimes a sensor will not fit at the desired location on or near the bearing housing because of an obstruction or because a suitable flat surface is not available. In these cases, it may be necessary to use a bracket extending from the desired measurement point to an area where the sensor can be mounted properly.

Make sure that the bracket itself does not introduce any extraneous vibrations. The bracket must not bend or flex. Even a small amount of flexing in the bracket may result in unreliable readings. Only a stiff bracket is able to transfer the vibration from the machine to the sensor without adding vibration due to the natural resonance frequency of the bracket. As a general rule, even the shortest bracket will require fabrication from 1/2-inch steel plate.

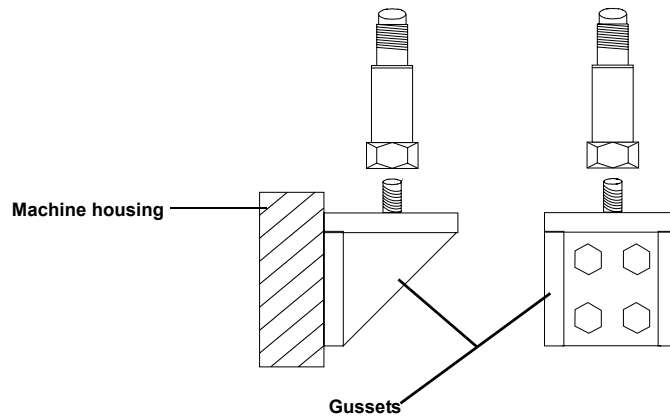

All brackets should be tested for resonance in the frequencies that the sensor will monitor. If possible, the bracket design should be approved by your sensor or system supplier. Contact Technical Support for assistance.

Sensor Cable Guidelines

This section describes some common cable guidelines to get the signal from the sensor to the monitoring device.

Sensor Connections and Power

Most of the 9000 series sensors are two-wire, IEPE accelerometers. There are also 9000 series sensors that have a built-in integrator to produce a velocity signal, as well as combination accelerometer/temperature sensors. The pin connections on the sensors are listed in the following table.

Connector Pin	Function
Shell	Ground, connected to cable shield
A	IEPE sensor power and signal
B	IEPE sensor signal return (signal common)

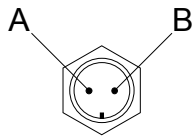
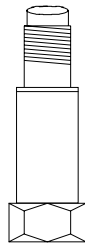

Side View

End View

Combination accelerometer/temperature sensors have three pins.

Connector Pin	Function
Shell	Ground, connected to cable shield
A	IEPE sensor power and signal
B	IEPE sensor signal return (signal common) and temperature common
C	Temperature sensor signal and power

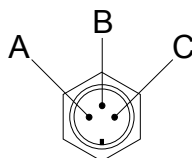
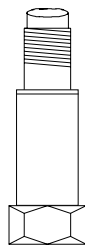

Side View

End View

Cable Installation

The cable from the sensor is a critical component in getting the signal to the monitoring device. The 2-wire cables with shield listed below are dedicated, one per sensor, to carry sensor signals to the monitoring device.

Cable run at 10 kHz	Maximum attenuation	No. of channels/cable	Cable diam.	Belden No.	Max. Temp.	Alpha No.
Up to 500 ft (152 m)	6 dB (2:1)	1	0.168 in 4.27 mm	8641	140° F 60° C	2400C
Up to 500 ft (152 m)	12 dB (4:1)	1	0.175 in 4.45 mm	8761	140° F 60° C	2401C
		3	0.310 in 7.87 mm	8777	176° F 80° C	6010C
		6	0.390 in 9.91 mm	8778	176° F 80° C	6012C
		12	0.480 in 12.2 mm	9768	176° F 80° C	6017C
Up to 1000 ft (304 m)	6 dB (2:1)	3	0.370 in 9.40 mm	9730	140° F 60° C	6073C
		6	0.480 in 12.12 mm	9731	140° F 60° C	6076C
Up to 1500 ft (457 m)	12 dB (4:1)	12	0.660 in 16.7 mm	9734	140° F 60° C	6079/ 12C

Cable run at 10 kHz	Maximum attenuation	No. of channels/cable	Cable diam.	Belden No.	Max. Temp.	Alpha No.
Up to 4000 ft (1219 m)	6 dB (2:1)	1	0.204 in 5.18 mm	8762	140° F 60° C	2411C
		3	0.340 in 8.64 mm	9873	176° F 80° C	6033C
		6	0.430 in 10.9 mm	9874	176° F 80° C	6036C
		12	0.590 in 15.0 mm	9877	176° F 80° C	6042C

Cable length

The nomograph below provides a simple, graphical method for obtaining the expected maximum frequency capability of an IEPE measurement system. The maximum peak signal voltage amplitude, cable capacitance, and supplied constant current must be known or presumed.

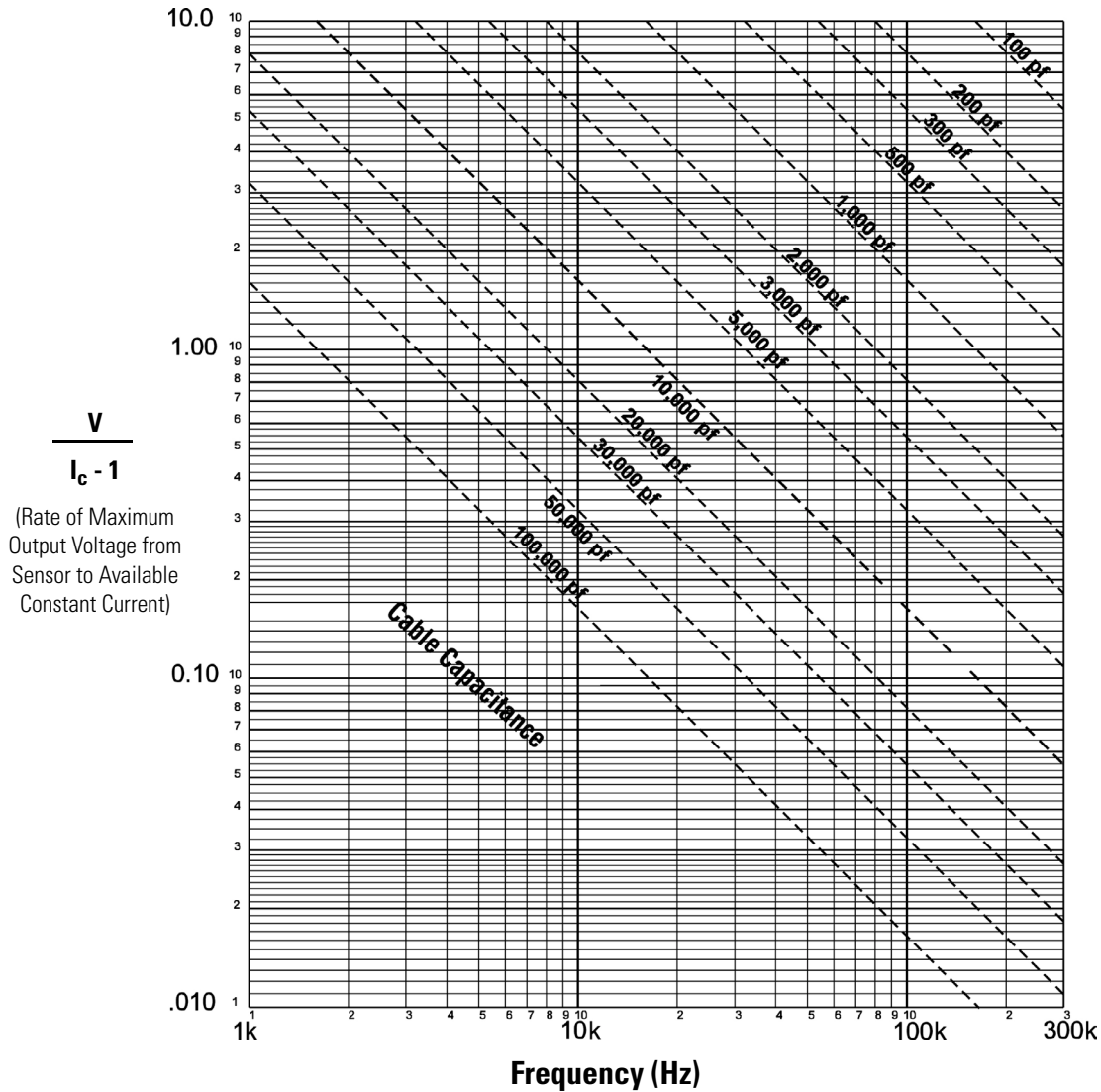

f_{max} = Maximum frequency given the following characteristics

C = Cable capacitance (pF)

I_c = Constant current level from power unit (mA)

V = Maximum output voltage from sensor (volts)

10^9 = Scale factor to equate units

For example, when running a 100ft. cable with a capacitance of 30 pF/ft, the total capacitance is 3000 pF. This value can be found along the diagonal cable capacitance lines. Assuming the sensor operates at a maximum output range of 5 volts and the constant current signal conditioner is set at 2 mA, the ratio on the vertical axis can be calculated to equal 5. The intersection of the total cable capacitance and this ratio result in a maximum frequency of approximately 10.2 kHz.

The nomograph does not indicate whether the frequency amplitude response at a point is flat, rising, or falling. For precautionary reasons, it is good general practice to increase the constant current (if possible) to the sensor (within its maximum limit) so that the frequency determined from the nomograph is approximately 1.5 to 2 times greater than the maximum frequency of interest.

Reducing electrical interference

The small electrical signal coming from a sensor can be affected by electrical interference. Make every effort to reduce the electrical interference in cables to the lowest acceptable levels. Interference can come from many sources, including power cables, switching devices, motor controllers, walkie-talkies, robot transmitters, arc welders, induction heating equipment, motors, and high voltage ignition systems.

The following methods are effective for minimizing electrical interference:

- Use twisted pair wires in each cable.
- Use individual foil shields around each pair, with a shield drain wire grounded at only one point for each shield. Do not ground the shield at both ends of the cable. Grounding the cable shield at both ends causes a “ground loop.” This can cause interference because in most cases the ground potential differs at the two ends.
- Electrically isolate (insulate) each sensor circuit from all others.
- Surround all cables with grounded steel conduit where possible.
- Do not use conduits containing sensor cables for any other circuits.
- Avoid running 9000 series sensor cables parallel to other cables, such as non-9000 series sensor, or communication cables.
- Avoid running sensor cables parallel to power wiring. When this cannot be avoided, make sure that sensor cables are at least 12 inches away from all power wiring carrying 120 V or less. For power circuits of 120–240 V, the minimum spacing is 24 inches. For circuits of 480 V or higher, the minimum spacing is 48 inches.
- If the cable must cross power wiring, maintain the above spacing between the wires. Cross the wires at a right angle (90°) to minimize interference.
- Make sure the cable is securely fastened to reduce low frequency noise from cable movement. This is particularly important at the sensor end of the cable.

For a sensor with a top exit cable connection, make sure there is at least 6 inches of clearance above the machine surface to allow for movement of the sensor and cable. Clamp the cable within 6 inches of the sensor, allowing enough room for the cable to bend without damage. Clamp the cable at intervals to prevent movement.

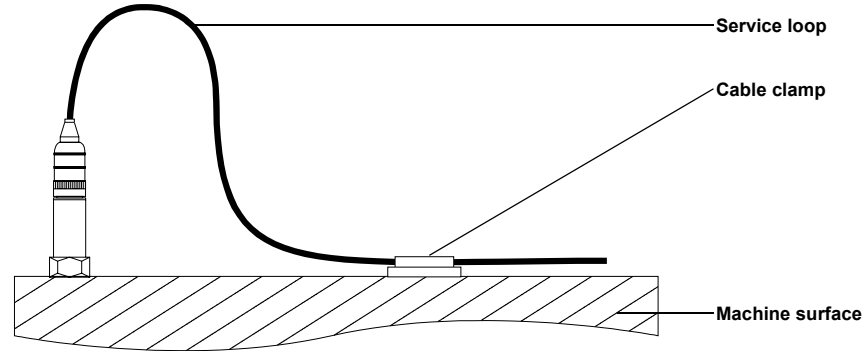

For sensors with a side exit cable connection, clamp the cable 3–4 inches from the sensor. Clamp the cable at intervals to prevent movement.

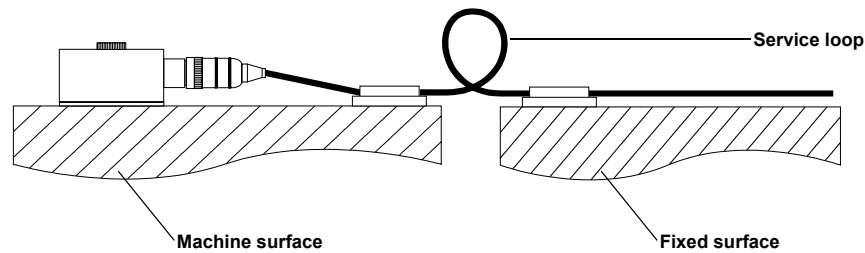

Cable construction

The sensor cable should be twisted pair with its own foil shield. Do not ground the cable shield drain wire at both ends. The shield connections should be carried through any junction boxes without connecting to a ground or other shields.

If the end of the sensor cable is in a location where it will be splashed or hosed down, coat it with RTV silicone rubber sealant to prevent fluids from entering the cable.

- At the sensor end, use RTV in and around the connector and cable entry to the connector.
- At the opposite end to the sensor, terminate the cable in a NEMA housing using proper cable entry connectors that create a tight seal around the cable and the entry hole of the housing.

Splicing cables

Splices in cables are acceptable if the connections are soldered. Splices must be located in a junction or conduit box for access. Coil any excess cable in the junction or conduit box, making sure that any exposed (bare) cable shield is taped off so it cannot touch the junction or conduit box. If necessary, you can shorten the armored cable from an accelerometer or velocity sensor by carefully cutting away the armor. Grind or file the cut armor to remove all sharp edges.

Cable Conduit Guidelines

All signal wiring should be run in grounded conduit, where it is protected from damage and external influences. The conduit must be installed with proper drain points so that water from condensation and other sources does not build up around the cable.

Cables in conduit

When cables are run in steel conduit, the conduit must be grounded per NEC and local code requirements. Where necessary, flexible interlocked steel conduit can be used. Note that flexible conduit is not as effective against RF/EM interference as solid conduit. No wires or cables other than sensor wires or cables should be run in the same conduit.

In high humidity areas, outdoors, or where the sensor may get wet, the conduit should be protected to prevent water from entering. If the conditions could cause condensation in the conduit, use rigid metallic conduit or liquid-tight flexible conduit with suitable fittings.

The “far” end of the conduit should be protected to prevent water from entering. Provide appropriate condensate drains at low points in the conduit runs to allow condensation to escape.

If a water-resistant seal is required, you can also use pipe joint sealing compound on fittings before screwing connectors to the sensor body. Coat the terminal strip inside the junction box with RTV silicone rubber after the cables are connected. Do not use sealant on the gasket surfaces.

Conduit runs to panels

Make sure the conduits are large enough to accommodate the signal cables plus space for servicing. The maximum acceptable cable length from sensor to monitoring device depends on the type of sensor, the frequencies of interest, the grade of cable, and the monitoring device. Follow the manufacturer’s specifications for cable length and grade, or refer to the table under “Cable Installation” on page 10.

Conduit boxes

Use a conduit or junction box to protect any connections or splices in the sensor cable.

- In wet areas, use NEMA-4X rated box. You can also use a 1/2 or 3/4-inch trade size conduit body with gasketed cover, mounted vertically to prevent water entry into the box.
- Locate the conduit box so that 1–2 inches of cable from the sensor extends into the box.
- Use rigid thin wall or liquid-tight flexible conduit on the output cable.
- Ground the box and conduit to avoid electrical and radio frequency interference.

Connecting 9000 Series Sensors to Monitors

The following drawings show the connections between 9000 series sensors and the following types of monitors: 5800 monitors, 6600 monitors, XM modules, and Enwatch units. These show the most common connections. Refer to the manual for your particular monitor for the wiring specific to your monitor.

CONNECTING 9000 SERIES TRANSDUCERS TO A 5800 MONITOR

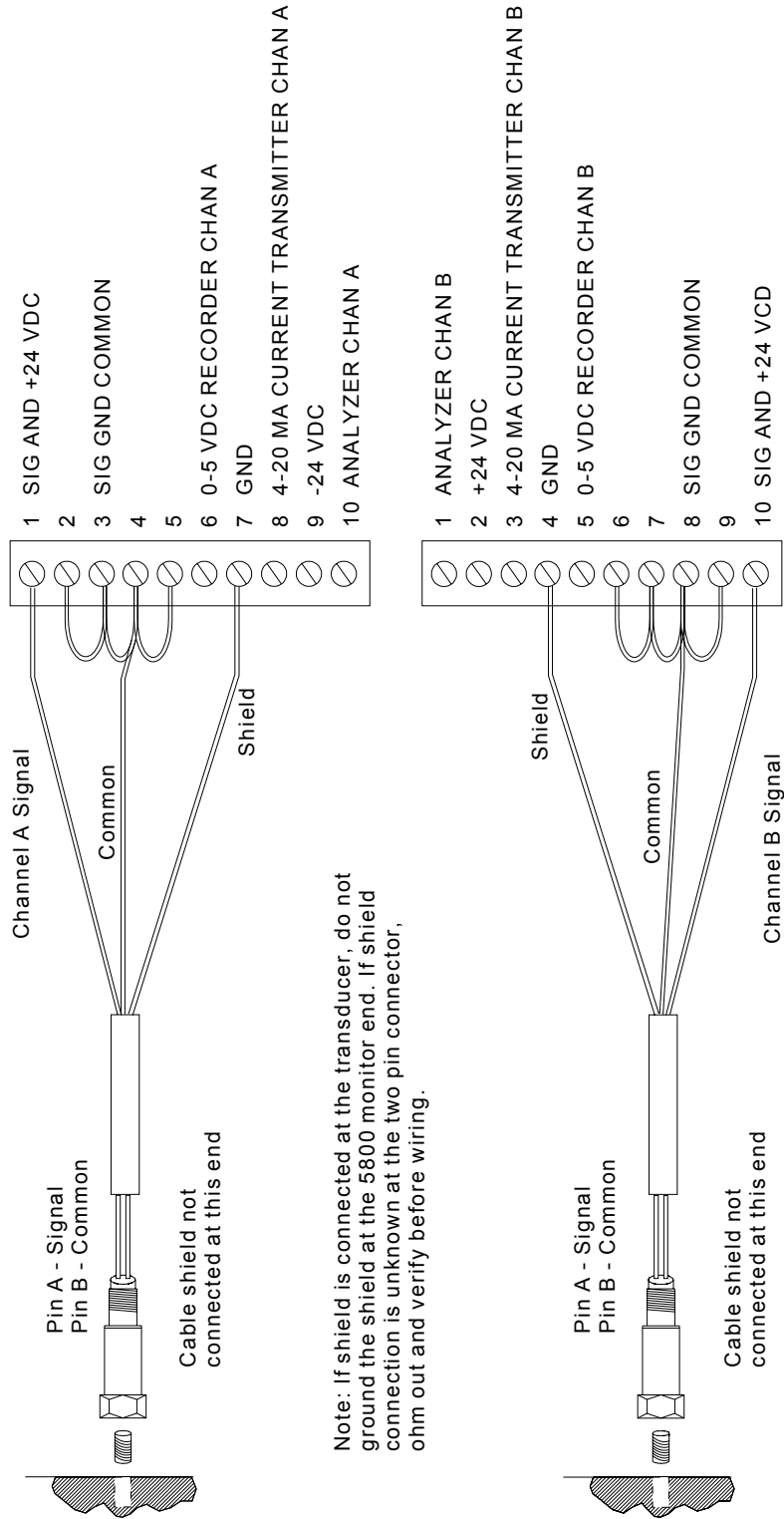

CONNECTING 9000 SERIES TRANSDUCERS TO A 6600 MONITOR

Note: IEPE transducers require constant current diodes attached to the backplane, one per active channel. Refer to Reference Drawing A39588+ for E39588 constant current diode assembly.

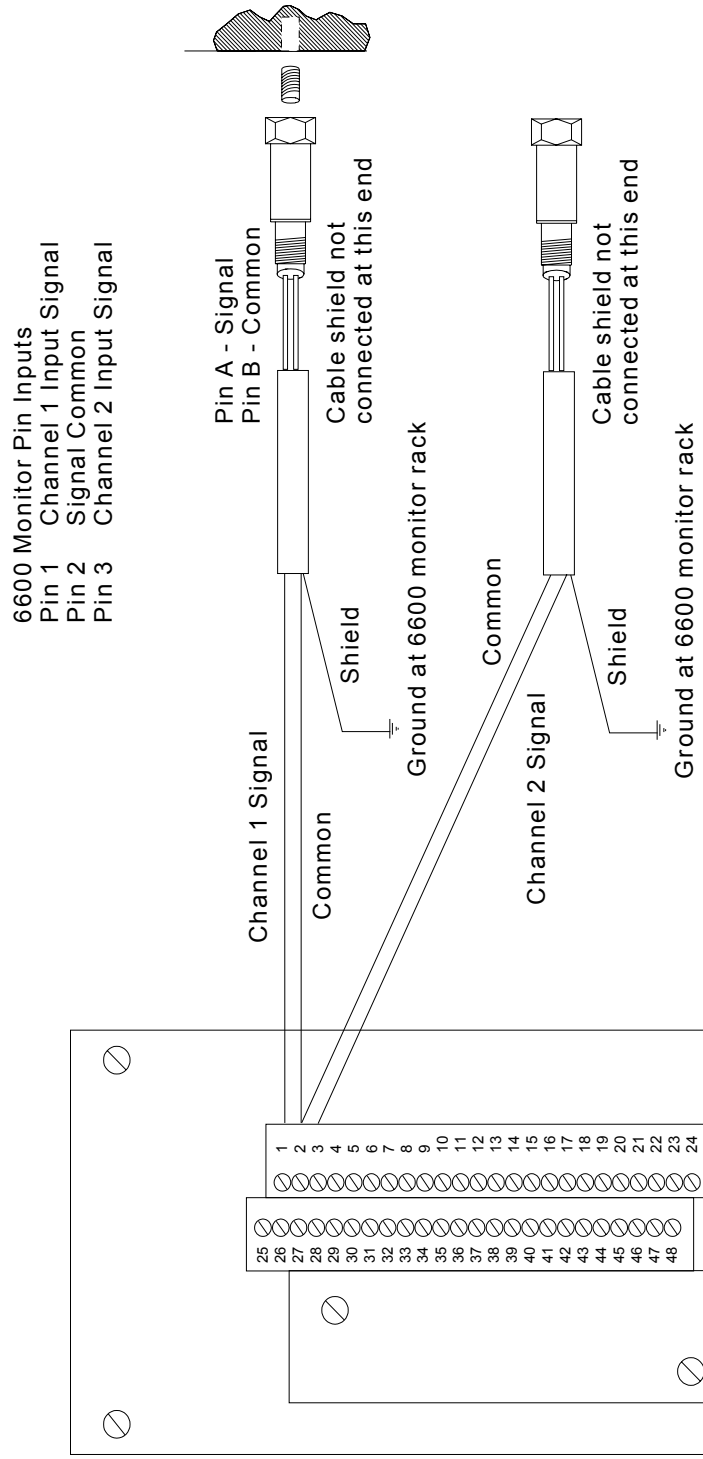

Note: If shield is connected at the transducer, do not ground the shield at the 6600 monitor end. If shield connection is unknown at the two pin connector, ohm out and verify before wiring.

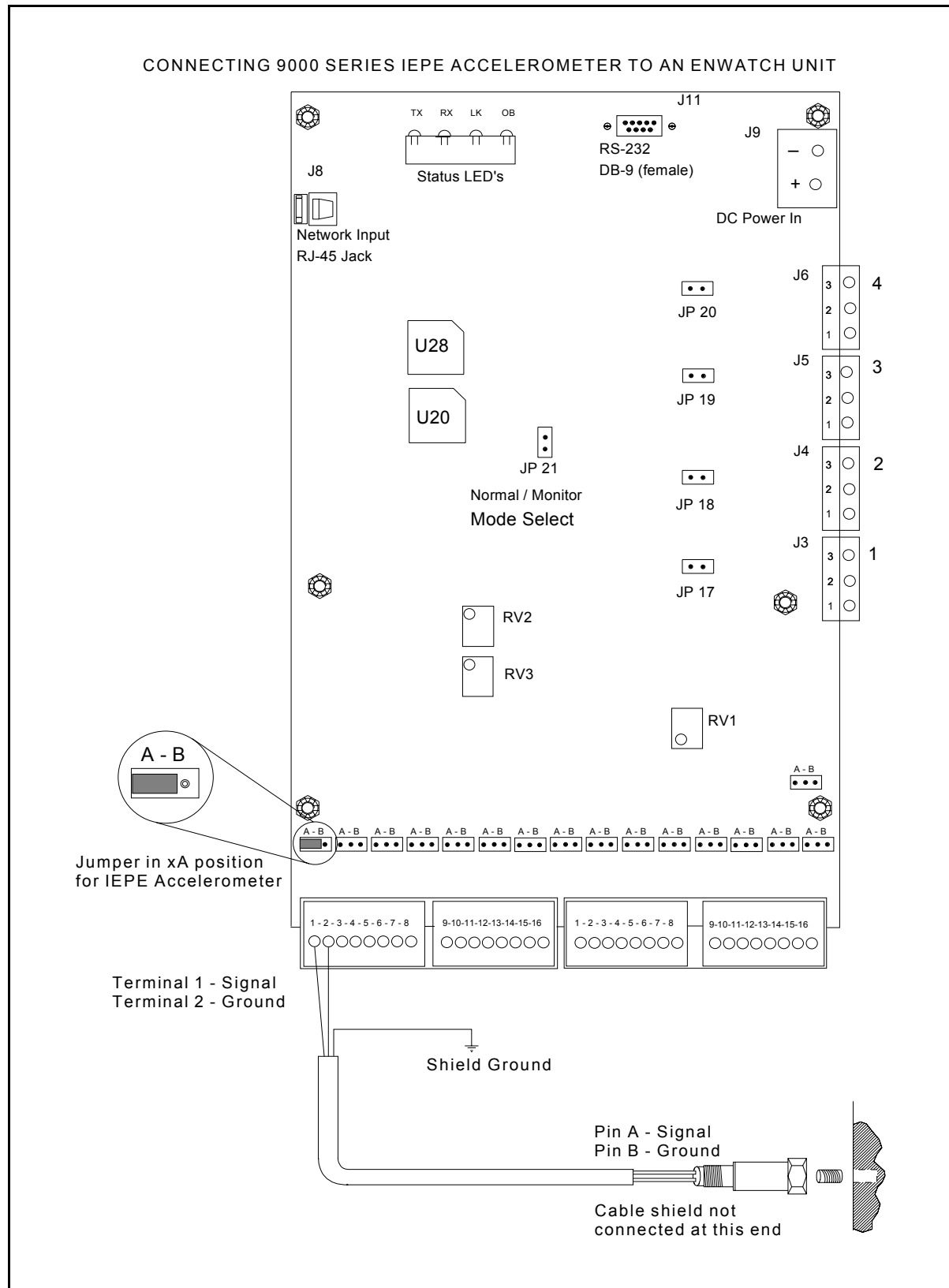

CONNECTING 9000 SERIES SENSORS
TO XM-120/121/122 VIBRATION MODULE CHANNEL 1

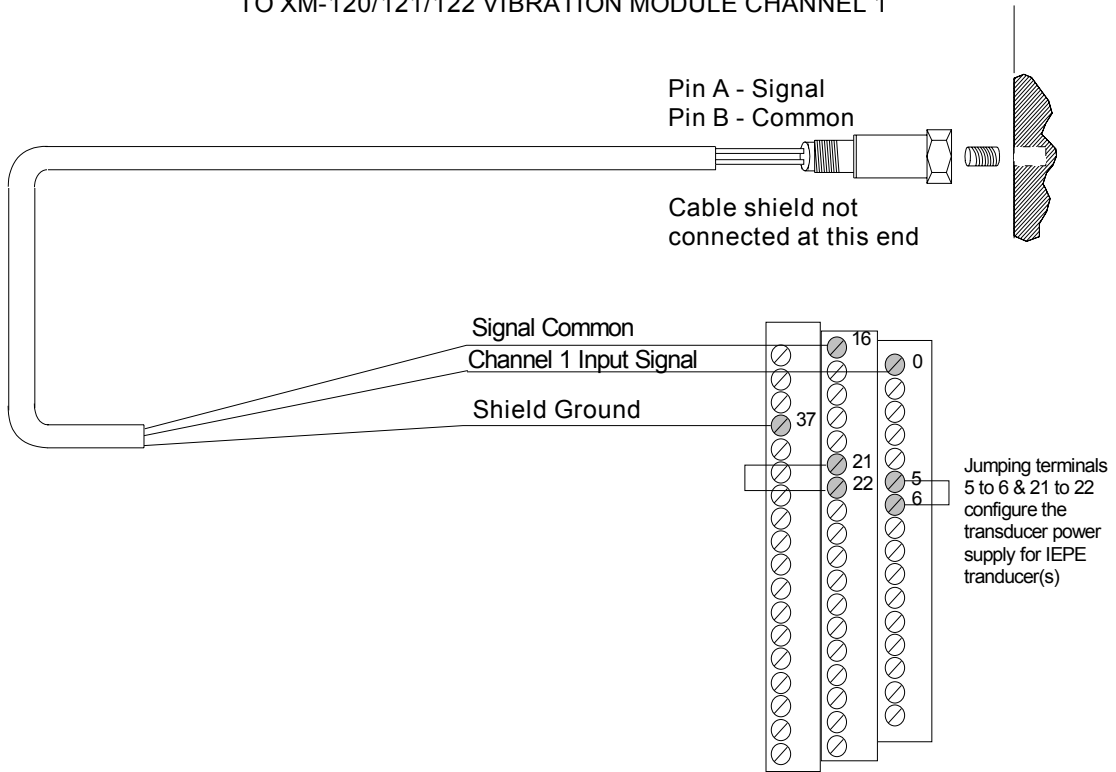

Note: You may ground the cable shield at either end of the cable. Do not ground the shield at both ends. Recommended practice is to ground the cable shield at the XM terminal base and not the sensor.

Note: The internal transducer power supply is providing power to the 9000 sensor.

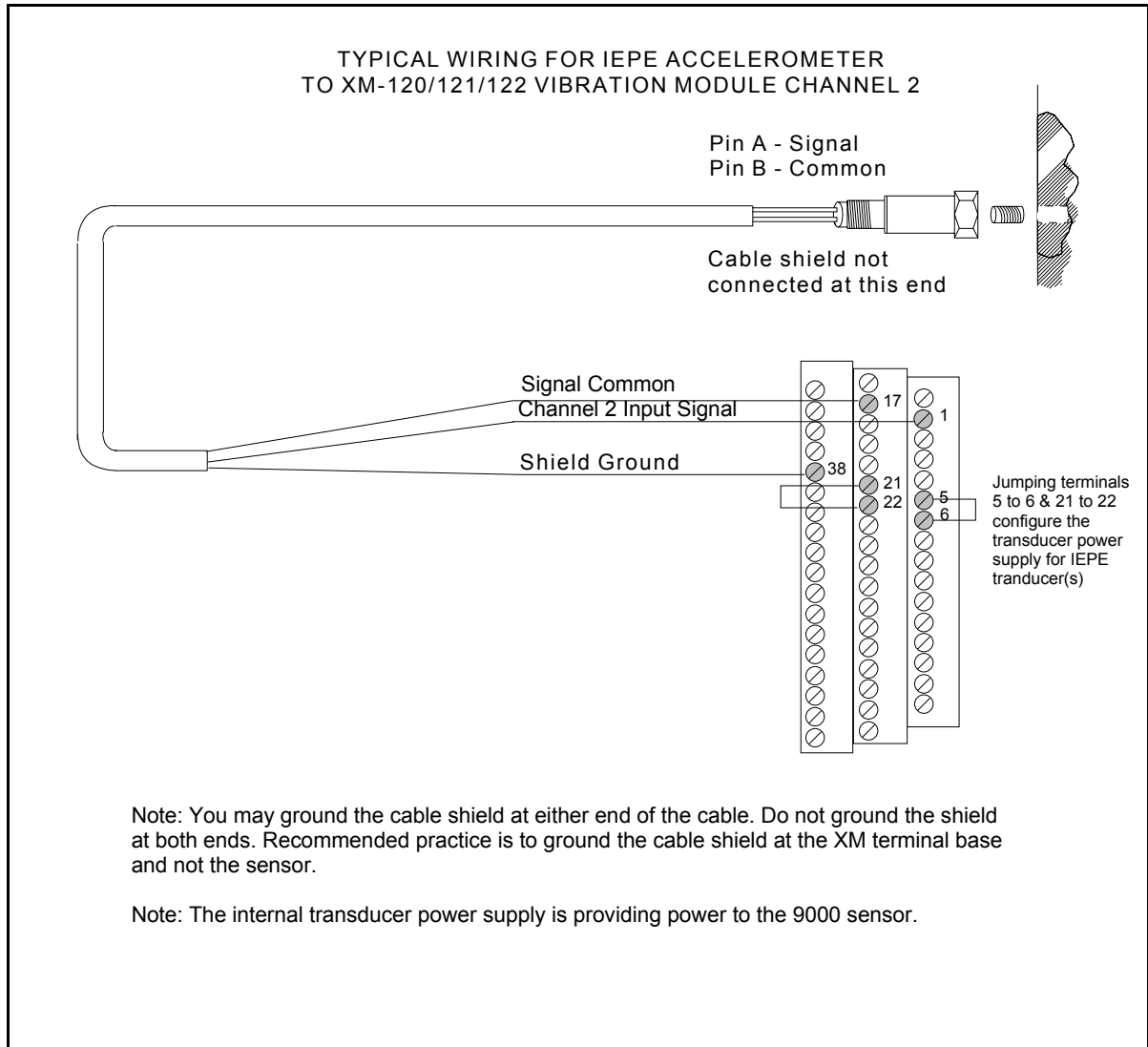

Index

5800 monitors 15
6600 monitors 15

A

adhesive mounting 7
attenuation, signal in cable 10

B

Belden number, cable 10
bracket mounting sensors 8

C

cable
 coaxial 7
 conduit 14
 conduit boxes 14
 construction 13
 guidelines 9
 installation 10
 length 10, 11
 reducing electrical interference 12
 splicing 14
coaxial cable 7
conduit 14
conduit boxes 14
connecting
 5800 monitors 15
 6600 monitors 15
 Enwatch unit 15
 XM modules 15
connections, sensors 9

E

Enwatch unit 15

G

general purpose sensors 2

H

high frequency sensors 3
high temperature sensors 4

I

insulated mounting 6
interference, reducing 12

J

junction boxes 14

L

low frequency sensors 3

M

mounting sensors
 adhesive 7
 brackets 8
 insulated housing 6
 overview 5
 set screws 6
 stud 5
 torque 6

O

overview, sensors 1

R

reducing electrical interference 12

Index

S

sensors

- connections 9
- general purpose 2
- high frequency 3
- high temperature 4
- low frequency 3
- mounting 5
- mounting on an insulated housing 6
- mounting with a bracket 8
- mounting with a stud 5
- mounting with adhesive 7
- overview 1
- triaxial 3
- velocity output 4

set screws 6

splicing cable 14

T

torque, sensor mounting 6

transducers

See sensors

triaxial sensors 3

V

velocity output sensors 4

X

XM modules 15