



Instruction

MI 019-590
March 1998

75LBA - B

Analog Input Liquid Batch Controller



A Siebe Group Company

Contents

Figures.....	ix
Tables.....	x
1. Introduction.....	1
Functions	1
Totalizers	1
Operation	1
Output	2
Hi/Lo Alarm Outputs	2
Total Labels	3
Ratemeter	3
Operation	3
Trending	3
Hi/Lo Alarm Outputs	4
Rate Label	4
Rate Analog Output	4
Batching	4
Operation	4
Top-Off	5
Density Calculations	5
Reference Documents	6
Standard Specifications	6
Totalizers	6
Ratemeter	6
Power	6
Ambient Temperature Limits	7
Relative Humidity Limits	7
Inputs	7
Outputs	7
Panel-Mounted Enclosure	8
Field-Mounted Enclosure	8
Wiring Connections	8
Agency Approval	9
Approximate Mass	9
Pollution Degree II	9
Overvoltage Category II	9

2. Installation	11
Unpacking and Inspection	11
Instrument Identification	11
Installing Panel-Mounted Instrument	12
Installing Field-Mounted Instrument	14
Preparing Enclosure for Field Wiring	14
Installing Instrument in Enclosure	14
Mounting Enclosure to a Surface	14
Mounting Enclosure on a Pipe	15
Wiring	15
I/O and Power Terminal Descriptions	15
TB1 – ac Power Input	16
TB2 – Digital Outputs, 24 V dc Power Input and Output	16
TB3 – Valve Relays	16
TB4 – Analog Output, Flowmeter and RTD Inputs	17
TB5 – Control Inputs and RS485 Communications	18
Wiring	18
ac Power Wiring	19
115 V Wiring	19
230 V Wiring	20
dc Power Wiring	21
Signal Wiring	22
3. Configuration/Program Mode	33
Accessing Program Mode	33
Key Functions	34
Row 1 Equations	35
Submenu 11 – Default Engineering Units (EGUs)	35
For Compensation of Rate/Total.....	35
Uncompensated Rate/Total.....	36
Submenu 12 – Engineering Units	36
Row 2 Cal. Inputs	36
Submenu 21 – Flow Input 4 to 20 mA Range	36
Uncompensated Rate/Totals	37
Compensated Rate/Totals	37
Submenu 22 – Input Rate Time Base	37
Submenu 23 – Flow Input Calibration	38
Submenu 24 – Flow Input Current Cut-Off Point	38
Submenu 25 – Temperature/Density Linearization Points	39
Submenu 26 – Density at STP (Standard Temperature and Pressure)	39
Submenu 27 – Temperature Input Selection	40
Submenu 28 – Temperature Input 4 to 20 mA Range	40
Submenu 29 – Analog Temperature Input Calibration	41

- Submenu 29 – RTD Temperature Input Calibration 41
- Row 3 Cal. Output 42
 - Submenu 31 – Running Total C2 Multiplier 42
 - Submenu 32 – Grand Total C3 Multiplier 43
 - Submenu 33 – Rate C4 Multiplier 43
 - Submenu 34 – Rate Time Base 44
 - Submenu 35 – Analog Output Parameter 44
 - Submenu 36 – Analog Output Calibration 45
 - Submenu 37 – Analog Output Trim 45
- Row 4 Totalizer 48
 - Submenu 41 – Running Totalizer Scaled Pulse Output 48
 - Submenu 42 – Running Total Decimal Point 48
 - Submenu 43 – Grand Total Decimal Point 49
 - Submenu 44 – Running Total Label 49
 - Submenu 45 – Grand Total Label 49
 - Submenu 46 – Batch Parameter Key Locks 50
- Row 5 Ratemeter 51
 - Submenu 51 – Trending 51
 - Submenu 52 – Ratemeter Decimal Point 51
 - Submenu 53 – Rate Display Label 51
- Row 6 I/O 52
 - Submenu 61 – Alarm Output Configuration 52
 - Submenu 62 – Alarm Output Labels 53
 - Submenu 63 – Alarm Output Timeout 54
 - Timeout 54
 - Latch 54
 - Follows 54
 - Submenu 64 – Run Mode Alarm Point Key Lock 55
 - Submenus 65, 66, 67, 68 – Control Inputs 1, 2, 3, B Functions 56
 - Submenu 69 – Reset Key Functions 57
- Row 7 Batch 58
 - Submenu 71 – Batching Operation 58
 - Submenu 72 – Top-Off Operation 58
 - Submenu 73 – Top-Off Set Point Value 58
 - Submenu 74 – Reset Function for Batch Totalizer 59
- Row 8 Other 59
 - Submenu 81 – Password 59
 - Submenu 82 – Baud Rate and Parity for Serial Communications 60
 - Submenu 83 – Unit ID Number and Response Delay Time for
Serial Communications 61
 - Submenu 84 – Instrument Tag Number 61
 - Submenu 85 – Diagnostics 62
- Configuration Reference Charts 63
 - Reset Key Function 63
 - Control Input Function 63
 - Alarm Output Function 64

Help Message List	66
Main Help Message.....	66
Submenu 11: Default Engineering Units (EGUs)	66
Submenu 12: Engineering Units	66
Submenu 21: Flow Input 4 to 20 mA Range.....	66
Submenu 22: Input Rate Time Base.....	66
Submenu 23: Flow Input Calibration.....	66
Submenu 24: Flow Input Current Cut-Off Point.....	66
Submenu 25: Temperature/Density Linearization Points	66
Submenu 26: Density at STP (Standard Temperature and Pressure)	66
Submenu 27: Temperature Input Selection.....	67
Submenu 28: Temperature Input 4 to 20 mA Range	67
Submenu 29: Analog Temperature Input Calibration	67
Submenu 29: Analog Temperature Input Calibration	67
Submenu 31: Running Total C2 Multiplier.....	67
Submenu 32: Grant Total C3 Multiplier	67
Submenu 33: Rate C4 Multiplier	67
Submenu 34: Rate Time Base	67
Submenu 35: Analog Output Parameter	67
Submenu 36: Analog Output Calibration	67
Submenu 37: Analog Output Trim	68
Submenu 41: Running Totalizer Scaled Pulse Output	68
Submenu 42: Running Total Decimal Point	68
Submenu 43: Grand Total Decimal Point.....	68
Submenu 44: Running Total Label	68
Submenu 45: Grand Total Label.....	68
Submenu 46: Batch Parameter Key Locks	68
Submenu 51: Trending.....	68
Submenu 52: Ratemeter Decimal Point	68
Submenu 53: Rate Display Label.....	68
Submenu 61: Alarm Output Configuration	68
Submenu 62: Alarm Output Labels.....	68
Submenu 63: Alarm Output Timeout.....	69
Submenu 64: Run Mode Alarm Point Key Lock.....	69
Submenu 65: Control Inputs 1	69
Submenu 66: Control Inputs 2	69
Submenu 67: Control Inputs 3	69
Submenu 68: Control Inputs B	69
Submenu 69: Reset Key Functions	69
Submenu 71: Batching Operation	69
Submenu 72: Top-Off Operation	69
Submenu 73: Top-Off Set Point Value	69
Submenu 74: Reset Function for Batch Totalizer	69
Submenu 81: Password	70
Submenu 82: Baud Rate and Parity for Serial Communications.....	70

Submenu 83: Unit ID Number and Response Delay Time for
 Serial Communications 70
 Submenu 84: Instrument Tag Number 70
 Submenu 85: Diagnostics..... 70

4. Normal Operation..... 71
 Key Functions 71
 Accessing Run Mode from Program Mode 73
 Default Display 73
 Secondary Parameters 74
 Alarm Point Values 74
 Batching 75
 Reset Key 76
 Analog Flow Input 76
 Control Inputs 77
 Temperature Input 77
 Ratemeter Operation 77
 Analog Output 78
 Totalizer Pulse Output 79
 Run Mode Display Messages 79

5. Fault Isolation 81
 Replacing the Unit 81

6. Serial Communication..... 83
 Purpose 83
 Serial Communication Description 83
 Error Codes 84
 Classifications 84
 Control Commands 85
 Query Data Commands 86
 Load Data Commands 88
 Load Program Data Commands 89

Appendix A. Conversion Factors..... 95

Index..... 97

Figures

1	Panel-Mounted Enclosure — Mounting Dimensions	12
2	Panel-Mounted Enclosure — Cutout Dimensions	12
3	Panel Mounting Detail — O-ring and Mounting Clips	13
4	Field Mounting (NEMA 4X) Dimensions	14
5	Field Mounting (NEMA 4X) Pipe Mounting Detail	15
6	I/O and Power Terminal Locations	15
7	115 V ac Power Input	20
8	230 V ac Power Input	21
9	24 V dc Power Input	22
10	Analog Flow Input (External Power)	23
11	Analog Flow Input with 75LBA Powering Loop	24
12	4 to 20 mA Flow Input — Interfacing with IMT20 or MAG 8000 Transmitters	25
13	4 to 20 mA Flow Input — Interfacing with IMT10 or IMT 25 Transmitters	26
14	Control Inputs	27
15	Wiring dc Loads to Digital Outputs	27
16	Relay Contact Output Wiring	28
17	Analog Output (Internal Power)	28
18	Analog Output (External Power)	29
19	Analog Output (75LBA Powered by External 24 V dc)	30
20	4 to 20 mA Temperature Input (Internal Power)	31
21	4 to 20 mA Temperature Input (External Power)	31
22	3-Wire RTD Temperature Input	32
23	4-Wire RTD Temperature Input	32
24	Temperature Input Trim (Internal Power)	46
25	Batching Operation Schematic Diagram	76

Tables

1	Possible Failure Indications and Recommended Actions	81
2	Control Commands	85
3	Query Data Commands	86
4	Load Data Commands	88
5	Load Program Data Commands	89
6	Conversion Factors (Volume)	95
7	Conversion Factors (Mass)	95

1. Introduction

Functions

The 75LBA-....B Liquid Batcher is a compact, self-contained, microprocessor-based instrument that performs the following functions:

- ◆ Totalizes liquid flows in actual or standard volumetric engineering units or in mass engineering units
- ◆ Displays liquid flow rate in desired engineering units
- ◆ Displays temperature and density
- ◆ Provides manual or automatic liquid batching operations

The 75LBA-....B accepts an analog 4 to 20 mA input signal from the flowmeter proportional to flow rate. The 75LBA-....B can be used only with linear type flowmeters.

Totalizers

Operation



CAUTIONS:

1. All count functions are inhibited when the unit is in Program mode.
 2. Care should be taken to avoid loss of RTD input as errors in measurement could result.
-

The 75LBA-....B is equipped with two totalizers:

- ◆ an 8-digit running totalizer
- ◆ a 10-digit grand totalizer

Both totalizers are unidirectional: they can count only up. The totalizers can be configured to display uncompensated or compensated (temperature only) flow.

The 75LBA-....B accepts an analog 4 to 20 mA input from the flowmeter. Totals are calculated from the latest value of flow rate. The totalizers are updated every 140 msec. The accuracy of the totalizers is based on the accuracy of the analog input, ± 1 update.

The equations used to calculate total are:

Running Total

$$\text{Uncompensated} = \text{Total} + \frac{C_2 \times Q_{\text{input}} \times dt}{\text{Time Base}}$$

$$\text{Compensated (Standard Vol.)} = \text{Total} + \frac{C_2 \times \text{density} \times Q_{\text{input}} \times dt}{\text{std density} \times \text{Time Base}}$$

$$\text{Compensated (Mass)} = \text{Total} + \frac{C_2 \times \text{density} \times Q_{\text{input}} \times dt}{\text{Time Base}}$$

Grand Total

$$\text{Uncompensated} = \text{Total} + \frac{C_3 \times Q_{\text{input}} \times dt}{\text{Time Base}}$$

$$\text{Compensated (Standard Vol.)} = \text{Total} + \frac{C_3 \times \text{density} \times Q_{\text{input}} \times dt}{\text{std density} \times \text{Time Base}}$$

$$\text{Compensated (Mass)} = \text{Total} + \frac{C_3 \times \text{density} \times Q_{\text{input}} \times dt}{\text{Time Base}}$$

The equations above contain a running total multiplier (C_2) and a grand total multiplier (C_3). These multipliers allow the user to display the running total and grand total in separate engineering units. Common conversion factors are tabulated in Appendix A.

The decimal point for each totalizer is also independently configurable to provide the user with the resolution desired for each display.

The 75LBA-....B can be configured to reset these totalizers by using the Reset Key located on the front face keypad, by a remote control input configured for that function, or both.

Output

Transistor output T_4 provides a totalizer output pulse for remote totalization coincident with the 8-digit running totalizer. The pulse output duration can be configured for:

- ◆ Fast (125 μ sec)
- ◆ Medium (2 msec)
- ◆ Slow (50 msec)

The totalizer has a buffer capable of storing 255 scaled counts whenever the totalizer count rate temporarily exceeds the totalizer output rate. If the buffer capacity is exceeded, any further totalizer count will be lost from the totalizer pulse output, and the message *PULSE OVERFLOW* will appear on the display. The contents of this buffer are saved if the power is removed from the unit before all the counts have been output.

Hi/Lo Alarm Outputs

The 75LBA-....B is equipped with 3 outputs that have an alarm point associated with them. These outputs can be assigned for the 8-digit running totalizer.

Total alarm point is used to set the value at which the total alarm turns on. The output is turned on when the running total reaches the alarm point. The output can be configured to time out or to latch. In the Time-out mode of operation, the output can be configured to turn on for 0.01 to 99.99 seconds.

Configuring a value of 0.00 disables the timer and causes the output to stay latched until unlatched. The total alarm can be unlatched using the Reset key and/or a control input configured for that purpose.

Total Labels

Alphanumeric labels representing the running total and grand total engineering units can be configured into the 75LBA and will be shown on the display along with the totals. The label for each totalizer can be up to three characters. Available characters are A–Z, 0–9, “/”, “*” and space.

Ratometer

Operation



CAUTIONS:

1. All rate functions are inhibited when the unit is in Program mode.
 2. Care should be taken to avoid loss of RTD input as errors in measurement could result.
-

The 75LBA-....B has a 1/tau ratemeter with 6 digits of display. The 75LBA-....B can be configured to display uncompensated or compensated (for temperature only), flow rate. The rate is calculated approximately every 140 milliseconds and the display and output are updated approximately 2 times a second. The equations used to calculate rate are:

$$\text{Uncompensated Rate} = C_4 \times Q_{\text{input}} \times C_{\text{time base}}$$

$$\text{Compensated (Standard Vol.) Rate} = \frac{C_4 \times \text{density} \times Q_{\text{input}} \times C_{\text{time base}}}{\text{std density}}$$

$$\text{Compensated (Mass) Rate} = C_4 \times \text{density} \times Q_{\text{input}} \times C_{\text{time base}}$$

Rate can be displayed in any desired engineering units and the time base can be configured for seconds, minutes, hours or days. The engineering units and time base used for rate display and output can be different from those of the input rate. Common conversion factors are tabulated in Appendix A.

The decimal point is programmable to provide the user with the desired resolution on the display. If the calculated rate exceeds 999999 with no decimal point configured, the message **RATE OVERFLOW** appears on the display.

Trending

The trending function allows the ratemeter to average rate readings. The trending time window can be set from 0.5 to 7.5 seconds in 0.5-second steps. No averaging is performed when the trending time window is configured for 0.5 seconds. When the trending time window is

set to 1 second or more, the latest rate is averaged with previous 0.5-second values. For example, if trending is set for 2.0 seconds, the latest rate along with the previous three values are averaged.

The number of averaged values is reset on power up, or on exit from the Program mode. Overflows are not averaged.

Hi/Lo Alarm Outputs

The 75LBA-....B is equipped with three outputs that have alarm points associated with them. These outputs can be assigned to the flow rate as Hi and Lo alarms. The Hi output is turned on if the rate reaches or exceeds the Hi alarm point, and the Lo output is turned on if the rate reaches or is below the Lo alarm point. The alarm outputs can be configured to follow, time out, or to latch.

In the Follow mode of operation, the rate is compared to the Hi and Lo alarm points after each update. If an output is turned on, it remains on until the next rate update occurs, and then the output is either left on or turned off, depending on the comparison of the new rate with the alarm points.

In the Time-out mode, the outputs can be configured to turn on for 0.01 to 99.99 seconds. Configuring a value of 0.00 disables the timer and causes the outputs to latch until unlatched.

In the Latched mode, Lo and Hi alarms remain on until unlatched. Alarms can be unlatched from either a control input configured for that function, and/or from the Reset Key.

Rate Label

An alphanumeric label representing the rate unit of measure can be configured into the 75LBA-....B and shown along with the rate value on the display. This label can be up to three characters in length. Available characters are A–Z, 0–9, “/”, “*” and space.

Rate Analog Output

The 75LBA-....B provides an analog output that can be configured to be proportional to the displayed flow rate. The analog rate output range can be configured at both the 4 mA and 20 mA points. This permits analog rate indications from zero to full scale or of any desired portion of the rate range. The analog output can be digitally calibrated in Program mode.

Batching

Operation

The 75LBA-....B provides two types of batching operation, manual and automatic. A six-digit batch total is displayed in addition to the running total and grand total.

In the manual mode, the 75LBA-....B can batch using a single on/off valve. A batch is initiated by giving the unit a Start command. This can be done either by pressing the Start button on the front keypad, or by activating a control input that was configured for this function. When the unit receives the Start command, relay K2 is energized. This relay stays energized

until the unit receives a Stop command. The Stop command can be given by pressing the Stop button on the front keypad, or by activating a configured control input.

In the automatic mode, the 75LBA-....B can batch using either one or two on/off valves. If one valve is to be used, the user just enters the desired batch setpoint. If two valves are to be used, Ramp-up and Pre-warn values must also be entered. Relay K2 is energized when the 75LBA-....B receives a Start command. When the batch counter reaches the Ramp-up value, relay K1 is energized. Relay K1 is de-energized when the batch counter reaches the Pre-warn value. Relay K2 de-energizes when the final batch setpoint is reached. The Ramp-up and Pre-warn values are entered as percentages of the final batch setpoint. If the Ramp-up value is greater than or equal to the Pre-warn value, the 75LBA will operate in the single valve mode.

The batch counter can be configured to automatically reset to zero when the Start command is given, or it can be configured to require manual rezeroing prior to giving the start command.

If a control input is configured for the Stop batch function, the 75LBA-....B will ignore a Start command whenever that input is active. A Start command will also be ignored when the batch counter is greater than or equal to the batch setpoint.

Alarm outputs can be configured to act on the batch totalizer. See the chapter on Normal Operation for a more detailed description of batching.

Top-Off

The top-off function may be configured to be manual or automatic. This function allows the user to top off a batch.

In the manual mode, K2 relay is actuated when the top-off command is given. The command is given by pressing the Top-off key on the front keypad, or by actuating a control input configured for that function. K2 relay remains energized until the Top-off Key, or the control input, is released. The amount of material entering the batch can be read on the batch counter.

A top-off setpoint value must be entered when the top-off function is configured for automatic mode. When the top-off command is initiated, the K2 relay is energized. However, now the relay remains energized only until an amount of material equal to the top-off setpoint value has been added to the batch, then it automatically de-energizes. An equal amount is added to the batch each time the top-off command is given in this mode.

A top-off command is ignored if a control input has been configured for the stop function and that input is actuated.

Density Calculations

The 75LBA-....B can be configured to calculate density based on a temperature input. Density is a parameter in the flow equations for standardized total, and rate, and mass total and rate.

The input for temperature can be configured for a 4 wire platinum RTD following the ASTM curve, or as a 4 to 20 mA current input. You may also configure a constant value for density, in which case no temperature input is required.

The 75LBA-....B can be configured with a density-versus-temperature curve. The curve consists of a series of density and temperature data pairs. Up to twenty data pairs can be configured. Data pairs are entered in English units of pounds per gallon and degrees Fahrenheit, or Metric units of kilograms per liter and degrees Celsius (centigrade). The data pairs need not be entered in any particular order. Only one data pair is required if density is assumed to be constant (that is, constant temperature). Density is calculated approximately every half second.

A value for density at standard conditions must be entered as well when standardized calculations are desired. This is the density at standard temperature and pressure. The value is entered in units of pounds per gallon (English) or kilograms per liter (Metric).

Alarm outputs can be configured to act on density and temperature.

The analog output from the 75LBA can be configured to be proportional to the calculated density or input temperature.

Reference Documents

For additional information, please refer to the documents listed below:

PL 008-727 75LBA Ratemeter/Totalizer Parts List

DP 019-543 75LBA Dimensional Print

Standard Specifications







Totalizers

Grand Total	Displays 10 digits with 3 alphanumeric characters of measurement unit
Running Total	Displays 8 digits with 3 alphanumeric characters of measurement unit
Batch Total	Displays 6 digits in same units as running total

Ratemeter

Type	1/TAU
Display	6 digits with 3 alphanumeric characters of measurement unit
Trending	0.5 to 7.5 seconds in 0.5-second increments

Power

115 V 	+14%, -11%, 50/60 Hz, 0.2 A maximum, 7 W maximum, Fuse  , T200 mA, 250 V
230 V 	+14%, -11%, 50/60 Hz, 0.1 A maximum, 7 W maximum, Fuse  , T100 mA, 250 V
24 V 	18 to 27 V dc, 0.4 A maximum, 5 W maximum, Fuse  , T400 mA, 250 V

Ambient Temperature Limits

Operating	0 and 50°C (32 and 122°F)
Storage	-40 and 70°C (-40 and 158°F)

Relative Humidity Limits

0 and 85%, noncondensing

Inputs

Analog Flow	4 to 20 mA; proportional to flow rate	
Control	Quantity	4
	Type	Requires current sinking device such as contact closure-to-ground or NPN transistor-to-ground.
	Impedance	5.8 Kohm to +5 V dc
	Voltage	High = 3.5 to 24 V dc Low = 0.0 to 1.0 V dc
	Bounce	30 ms, minimum
RTD Temperature	Type	4-wire platinum RTD (ASTM curve)
	Impedance	100 ohm
	Response	2 Hz
	Resolution	14 bits
	Range	-196 to +454 degrees C (-320 to +850 degrees F)
Analog Temperature	Type	4 to 20 mA current loop

Outputs

Analog	4 to 20 mA optically isolated 12 to 27 V dc compliance voltage, 2 Hz response, programmed proportional to displayed rate, input temperature or calculated density	
Totalizer Pulse	Type	NPN transistor
	Rating	150 mA maximum, 30 V dc blocking maximum
	Operation	Outputs pulse for every increment of least significant whole digit on Batch and Running totals.
	Pulse width	Configurable from: Fast: 125 µs width, 1.5 kHz maximum Medium: 2 ms width, 200 Hz maximum Slow: 50 ms width, 10 Hz maximum

Alarms	Quantity	3
	Type	NPN transistors
	Function	Assignable for Hi/Lo limits for rate, temperature, density or batch total. Also assignable as \geq Running Total
	Rating	150 mA maximum, 30 V dc blocking maximum
	Operation	Configurable from: Follow (Rate only) Time out after 0.01 to 99.99 seconds Latch until acknowledged
Relays	Quantity	2
	Function	Both relays dedicated to the batching operation Relay K2 controls Valve 1 Relay K1 controls Valve 2 in automatic mode
	Contacts	Single form C, 240 V ac or 24 V dc 5 A resistive load
Power	24 V dc $\pm 5\%$, 100 mA maximum	

Panel-Mounted Enclosure

The panel-mounted instrument is in a Noryl enclosure with a polyester front panel; it can be mounted flush on a control rack or panel. The front face of the instrument is sealed to provide the environmental protection of NEMA Type 4X.

Field-Mounted Enclosure

The panel-mounted instrument is mounted flush in the door of a glass-filled polyester enclosure. This enclosure may be mounted to a surface or to a nominal DN 50 or 2-inch pipe. This enclosure meets the requirements of NEMA Type 4X.

Wiring Connections

Panel-Mounted Enclosure	Five terminal blocks are located on the rear surface of the enclosure. These terminal blocks accommodate all input and output terminations. For ac power wiring, use a minimum wire size of 18 ga. (1 mm ² , 600 V) and a maximum of 14 ga. (1.8 mm ² , 600 V). For panel mounted devices, include a disconnect switch in the installation, mounted in close proximity to the equipment and within easy reach of the operator, and clearly marked as the disconnecting device for the equipment. Switches and circuit breaker must comply with IEC 947.
Field-Mounted Enclosure	Same as for panel-mounted instrument. Access to terminal blocks is obtained by opening the enclosure door. Conduit entry ports and openings must be provided by the user.

Agency Approval

The 75LBA is Canadian Standards Association (CSA) certified for use in general purpose (nonhazardous) locations.

Approximate Mass

Panel-Mounted Unit	0.8 kg (1.75 lb)
Field-Mounted Unit	4 kg (8.8 lb)

Pollution Degree II

Overvoltage Category II

Installing Panel-Mounted Instrument

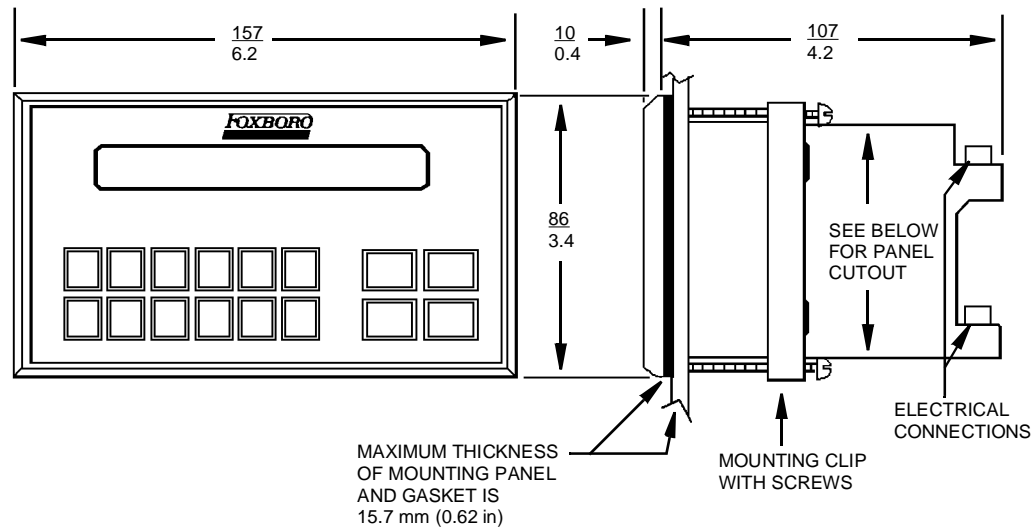

Figure 1. Panel-Mounted Enclosure — Mounting Dimensions

1. Prepare a cutout in the panel as shown in the preceding figure. See the next figure for minimum spacing requirements between units if more than one instrument is to be mounted on the same panel.

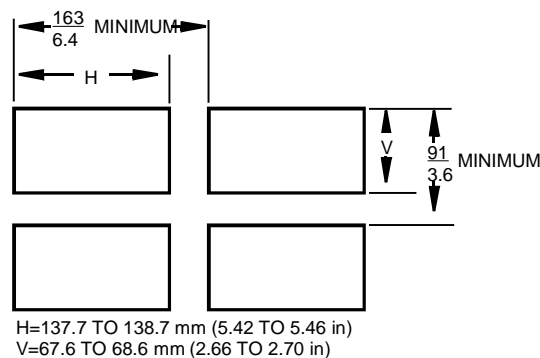

Figure 2. Panel-Mounted Enclosure — Cutout Dimensions

2. Place the O-ring gasket on the instrument and carefully seat it in the groove around the front bezel. This can be seen in the following figure.
3. Examine the two plastic mounting clips. A screw symbol molded into each clip indicates the proper orientation of the clip. The screw head should point toward the rear of the instrument. Also note the threaded holes on each side of the clip.

4. Insert the instrument into the panel opening.
5. Snap the two plastic mounting clips onto the instrument so that they sit in the notches on the instrument case (see the following figure).
6. Thread the four mounting screws through the threaded holes on the mounting clips and finger tighten them against the panel.
7. Carefully tighten the screws until the front bezel just touches the front panel.



CAUTION: Do not overtighten the mounting screws. Damage to the instrument can result.

NOTES:

1. A switch shall be included in the building installation.
 2. It shall be in close proximity to the equipment and within easy reach of the operator.
 3. It shall be marked as the disconnecting device for the equipment.
 4. Switches and circuit breakers must comply with IEC 947.
-

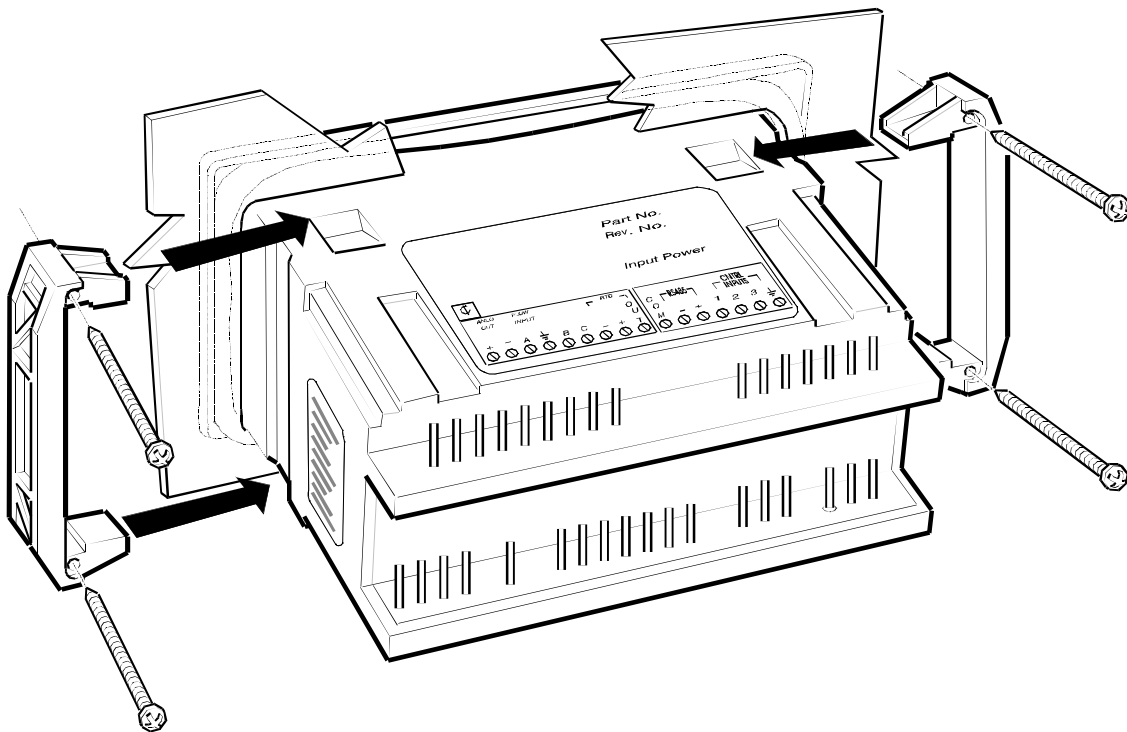

Figure 3. Panel Mounting Detail— O-ring and Mounting Clips

Installing Field-Mounted Instrument

Preparing Enclosure for Field Wiring

The field-mounted enclosure is supplied with a cutout of the proper size for the instrument. However, no openings or knockouts for wiring are provided. After planning the wiring route, the user must drill appropriate holes for wiring or conduit fittings, typically on the bottom surface of the enclosure.



CAUTION: To preserve NEMA type 4X environmental protection ratings, appropriate wiring fittings must be used and proper installation practices must be followed.

Installing Instrument in Enclosure

After preparing the field-mounted enclosure for wiring, follow steps 2–7 given above for panel mounting to install the instrument in the enclosure.

Mounting Enclosure to a Surface

To mount the field enclosure against a surface, use the four holes provided on the rear flange of the enclosure. See Figure 4.

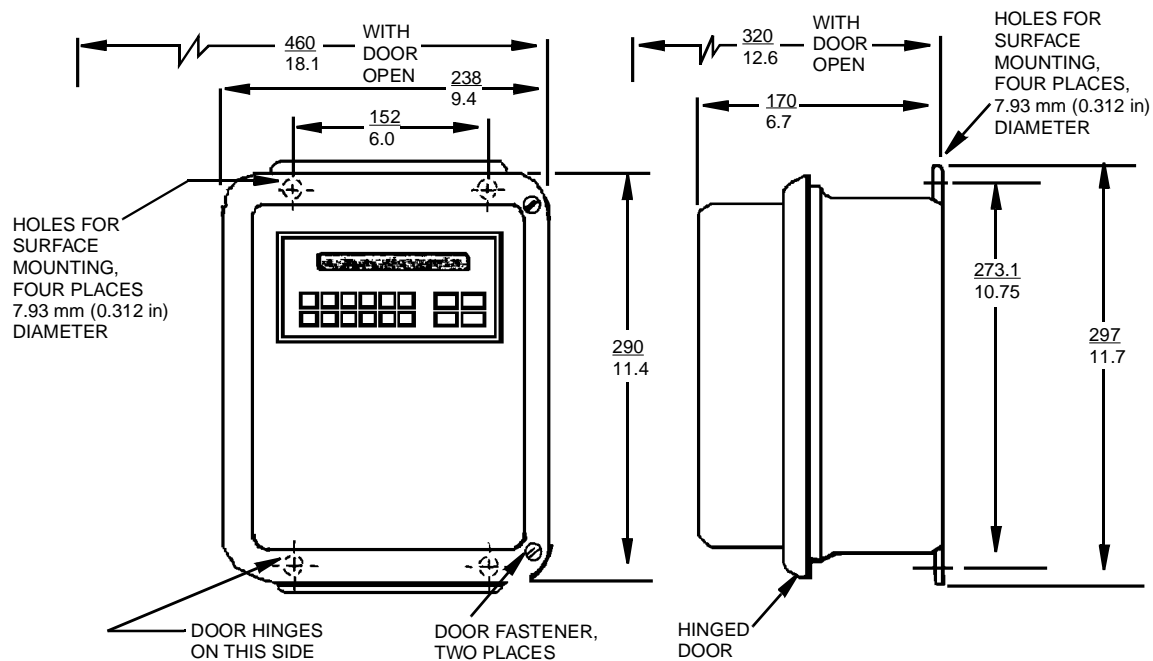

Figure 4. Field Mounting (NEMA 4X) Dimensions

Mounting Enclosure on a Pipe

To mount the field enclosure on a DN50 or 2-inch vertical pipe, securely fasten the two U-bolts provided. See Figure 5.

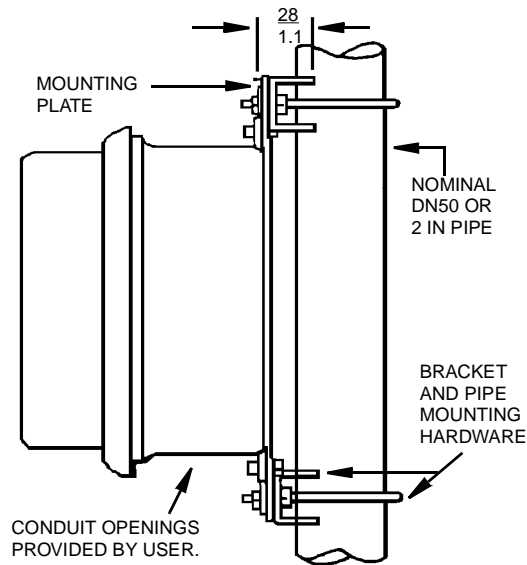

Figure 5. Field Mounting (NEMA 4X) Pipe Mounting Detail

Wiring

I/O and Power Terminal Descriptions

This section focuses on I/O and power terminal descriptions.

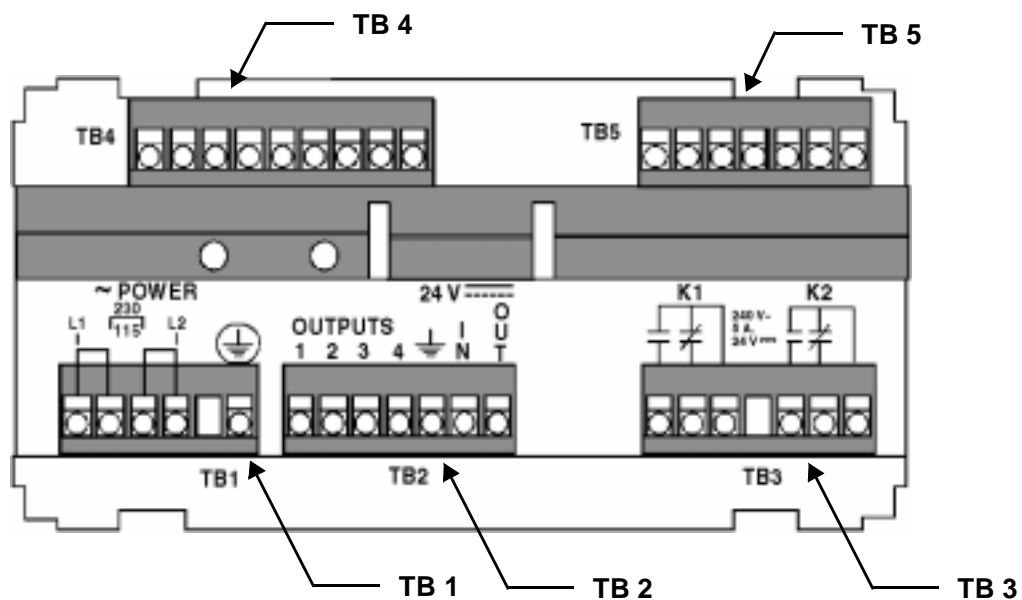

Figure 6. I/O and Power Terminal Locations

TB1 – ac Power Input

- L1 ac power live line
- L2 ac power neutral line
- Terminals 115/230 voltage selection jumpers
between L1 and L2 (See wiring instructions below.)
- ⏏ Safety earth (safety ground)



TB2 – Digital Outputs, 24 V dc Power Input and Output

- OUTPUT 1 Digital output T₁. Alarm 1.
- OUTPUT 2 Digital output T₂. Alarm 2.
- OUTPUT 3 Digital output T₃. Alarm 3.
- OUTPUT 4 Digital output T₄. Totalizer scaled pulse output.
- ⏏ dc common. When the unit is powered by 24 V dc, connect the negative side of the power supply to this terminal. When the unit supplies 24 V dc power for accessories, connect the accessory dc common to this terminal.
- 24 V dc IN When the unit is supplied by dc, connect the plus side of 18 to 27 V dc power supply to this terminal.
- 24 V dc OUT Positive 24 V dc accessory power. Connect this terminal to the accessory's positive 24 V dc input. Accessory power is available only when the unit is powered by ac.

TB3 – Valve Relays

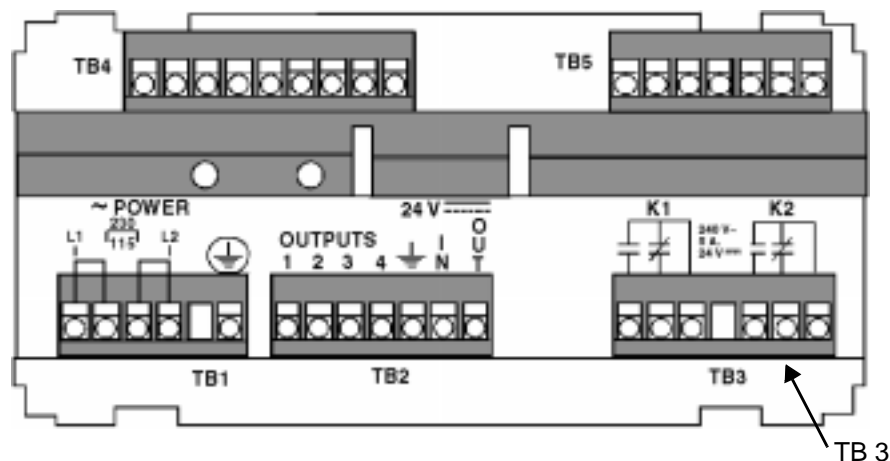

- K1 Relay outputs to operate valves for batching operation. A normally open and normally closed contact is provided for each relay. See Batching on page 4.
- K2

TB4 – Analog Output, Flowmeter and RTD Inputs

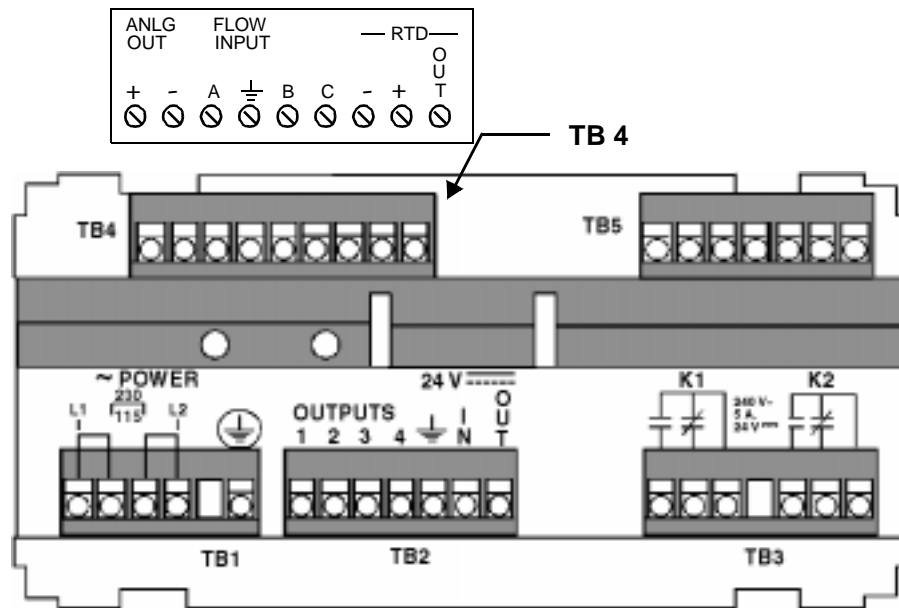

ANLG OUT +	The analog output positive terminal is connected to the analog circuit power supply positive or the 24 V dc OUT terminal on TB2. Maximum voltage applied to ANLG OUT + is 27 V dc. Minimum voltage is 12 V dc + load drop at 20 mA.
ANLG OUT -	The analog output negative terminal is connected to the analog load positive terminal. The 4 to 20 mA signal with respect to dc common is output at the ANLG OUT - terminal.
FLOW INPUT A	Flow analog input +.
⏏	dc common: dc common is the reference level for the flowmeter and control inputs. Inputs are active when connected to dc common and digital outputs conduct to dc common when in the <i>on</i> state. dc common is not connected to chassis earth (ground).
B	Programmable control input B; may be assigned to various functions as explained in the chapter on configuration.
C	Used for 4 to 20 mA analog temperature input. Negative lead from temperature transmitter connects to this terminal. See Figure 20 and Figure 21.
TEMP RTD - and +	Used for 4-wire platinum RTD input. See temperature input wiring diagram on page 32.
OUT	Used to power RTD. See Figure 21.



CAUTION: Connecting power directly across terminals labeled 4-20 FLOW INPUT "A" and ⏏ will cause severe damage to instrument.

TB5 – Control Inputs and RS485 Communications

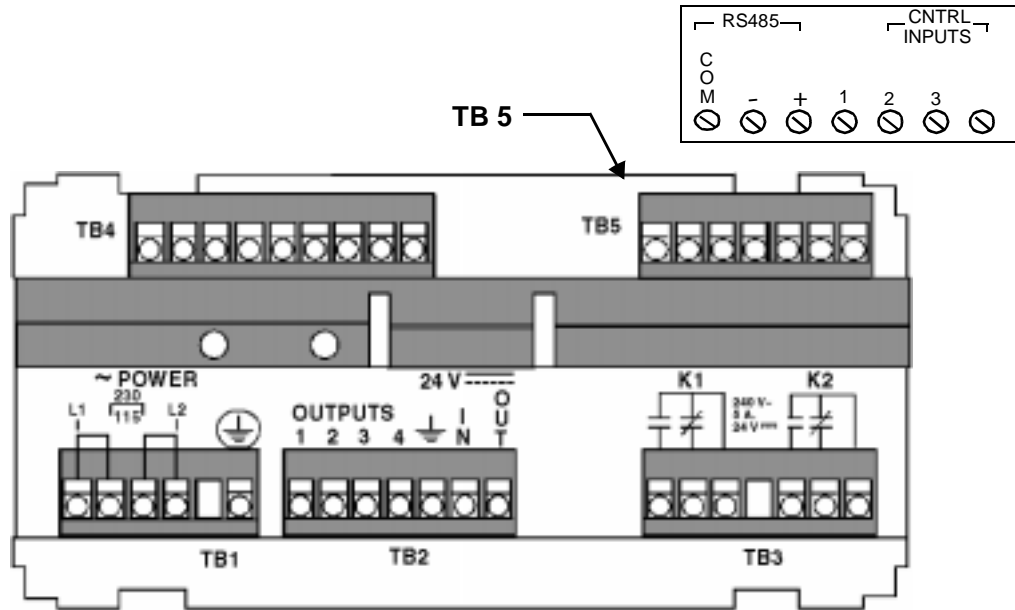

- RS 485 COM Communications common terminal. Connected to dc common by an internal 100 ohm resistor.
- RS 485- Communications differential signal input/output.
- RS 485+
- PRESSURE Used for 4 to 20 mA analog pressure input. Negative lead from pressure
- INPUT transmitter connects to this terminal.
- CONTROL Three programmable inputs that may be assigned to various functions as
- INPUTS 1-3 explained in the section on configuration. See also control input B on
- TB4. Control inputs are active when connected to dc common.



Wiring

The connectors for this instrument use compression-type wiring terminals. Follow the steps listed below to connect a wire to one of these terminals. The following illustration shows the screw terminal in detail.

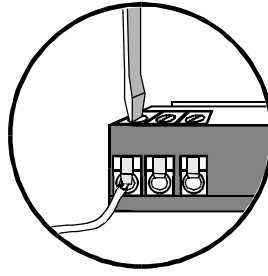



1. Using a small flathead screwdriver, turn the terminal screw counterclockwise until the clamp is fully open.
2. Strip the wire about 5 mm (0.2 inch).
3. Insert the wire until it stops.
4. Turn the terminal screw clockwise to tighten the clamp.
5. Check that the clamp grips the metal wire only and not the insulation.
6. Check that the wire is securely held in place.

ac Power Wiring

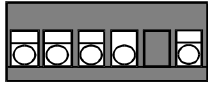

WARNING: Exposed terminals on the instrument power connector present a shock hazard when energized. Provide a power disconnect on the instrument's power line. The disconnect must be turned off when installing, servicing or removing the instrument. The live ac line (black or brown) to the instrument must be protected with a fuse as indicated in the wiring diagrams on next page.

115 V Wiring

1. Locate the instrument power (TB1) connector packaged in the accessory parts bag. It is a six-position screw terminal connector with a keying insert blocking one position. 
2. Prepare two jumper wires about 25 mm (1 inch) long of the same gauge as the power wires.
3. Wire the terminal as described below. (Also refer to the 115 V wiring diagram.)
 - ◆ Black (live) lead to terminal L1
 - ◆ White (neutral) lead to terminal L2
 - ◆ Green lead (safety earth/ground) to  terminal
 - ◆ Jumper L1 and L2 to their adjacent center terminals.
4. Plug the connector into the instrument's  POWER pins.
5. Carefully check the power wiring before applying power.

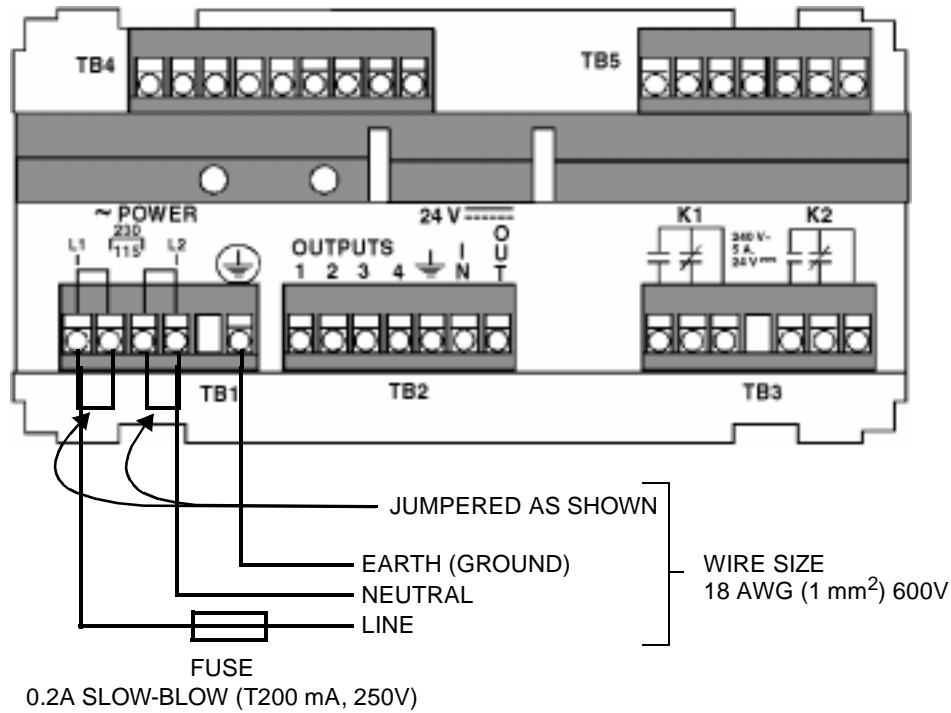

Figure 7. 115 V ac Power Input

230 V Wiring

1. Locate the instrument power (TB1) connector packaged in the accessory parts bag. It is a six-position screw terminal connector with a keying insert blocking one position.
2. Prepare one jumper wire about 25 mm (1 inch) long of the same gauge as the power wire.
3. Wire the terminal as described below (also see the 230 V wiring diagram below).
 - ◆ Black or brown lead (live) to terminal L1
 - ◆ White or blue lead (neutral) to terminal L2
 - ◆ Green or green/yellow lead (safety earth/ground) to terminal \oplus
 - ◆ Jumper center terminals together (see 230 V wiring diagram below)
4. Plug the connector onto the instrument's \sim POWER pins.
5. Carefully check power wiring before applying power.

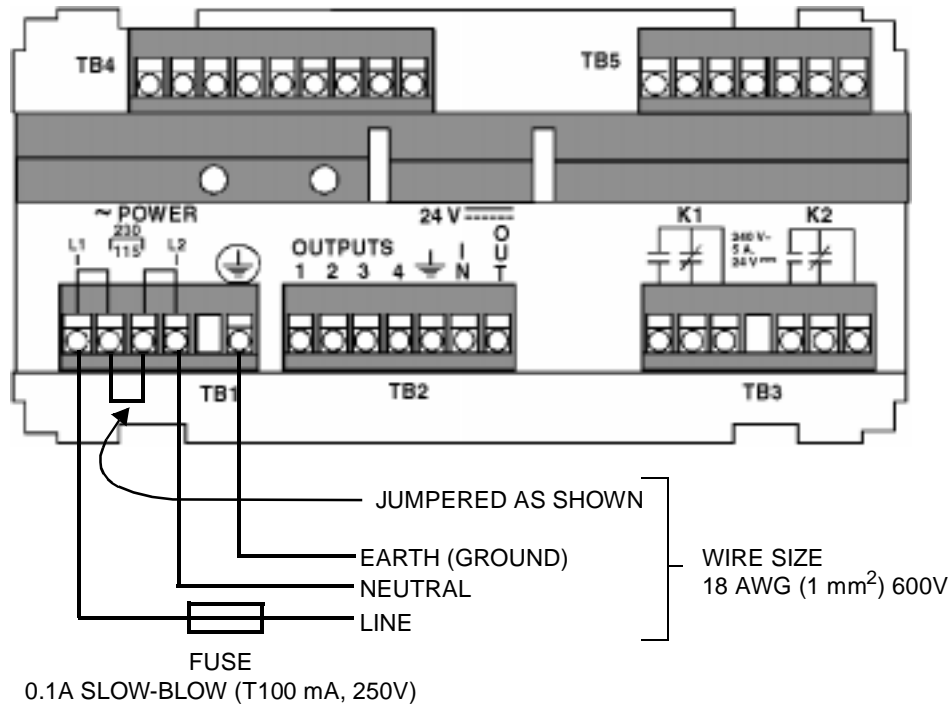

Figure 8. 230 V ac Power Input

dc Power Wiring



CAUTION: Provide a power disconnect on the instrument's power line. The disconnect must be turned off when installing, servicing or removing the instrument. Protect the +24 V dc line to the instrument with a 0.5A (T 500 mA, 250V) slow-blow fuse.

NOTE: When the 75LBA-....B is powered by 24 V dc it cannot provide power (via 24V DC OUT) for flow transmitter or analog output. These could typically be powered directly from the same supply that powers the 75LBA-....B. (See the illustration on page 30.)

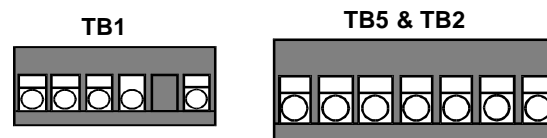

1. Locate the instrument TB1 and TB2 connector in the accessory parts bag. TB1 is a six-position screw terminal connector with a keying insert blocking one position. TB2 is a seven-position screw terminal connector with no keying insert.
2. Wire a safety earth (ground) to the \oplus pin on the TB1 connector.

3. Wire the TB2 connector as described in the dc power wiring diagram below.
4. Plug the TB1 connector into the instrument's \sim POWER pins.
5. Plug the TB2 connector into the instrument's OUTPUTS 24 V DC pins.
6. Carefully check the power wiring before applying power.

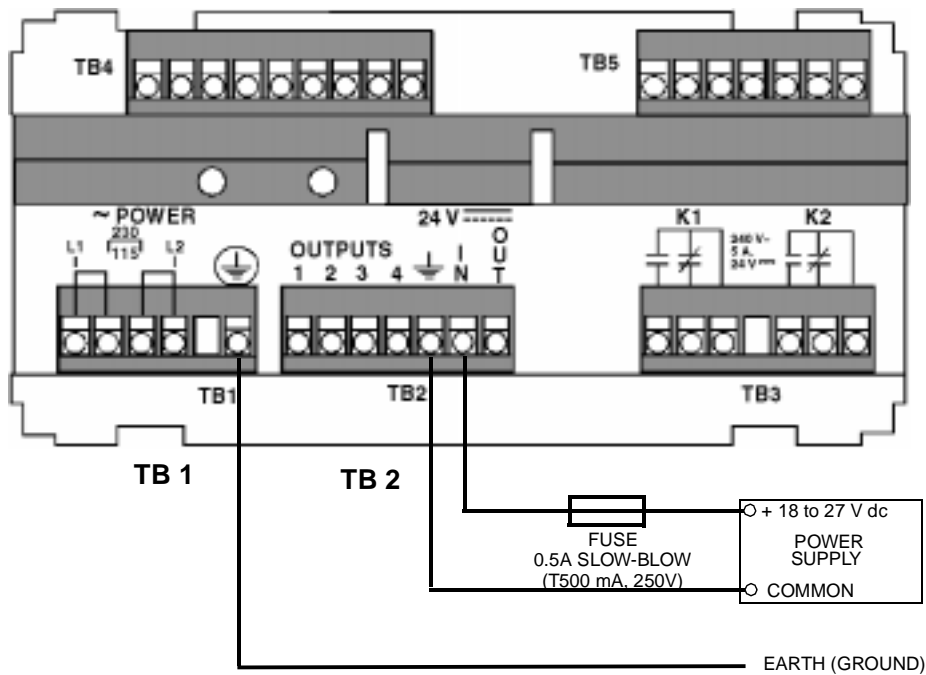

NOTE: SAFETY GROUND IS REQUIRED ONLY IF RELAYS ARE SWITCHING AC POWER; OTHERWISE IT IS OPTIONAL.

Figure 9. 24 V dc Power Input

Signal Wiring

Locate the instrument TB2, TB4 and TB5 and TB3 connectors packaged in the accessory parts bag.

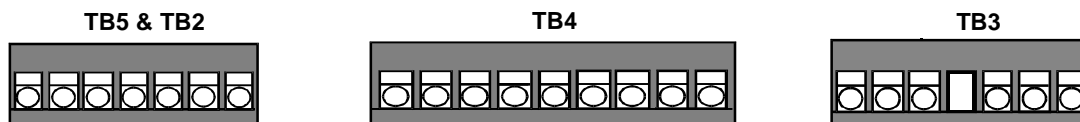

1. Wire the connectors as described in the wiring diagrams below. Refer also to the descriptions for TB2, TB3, TB4, and TB5 in the previous section named I/O and Power Terminal Descriptions.
2. Plug the connectors into the appropriate pins.



CAUTION: The two seven-pin connectors are not keyed and should be labeled to prevent their being placed on the wrong pins.

3. Carefully check the wiring before applying power.

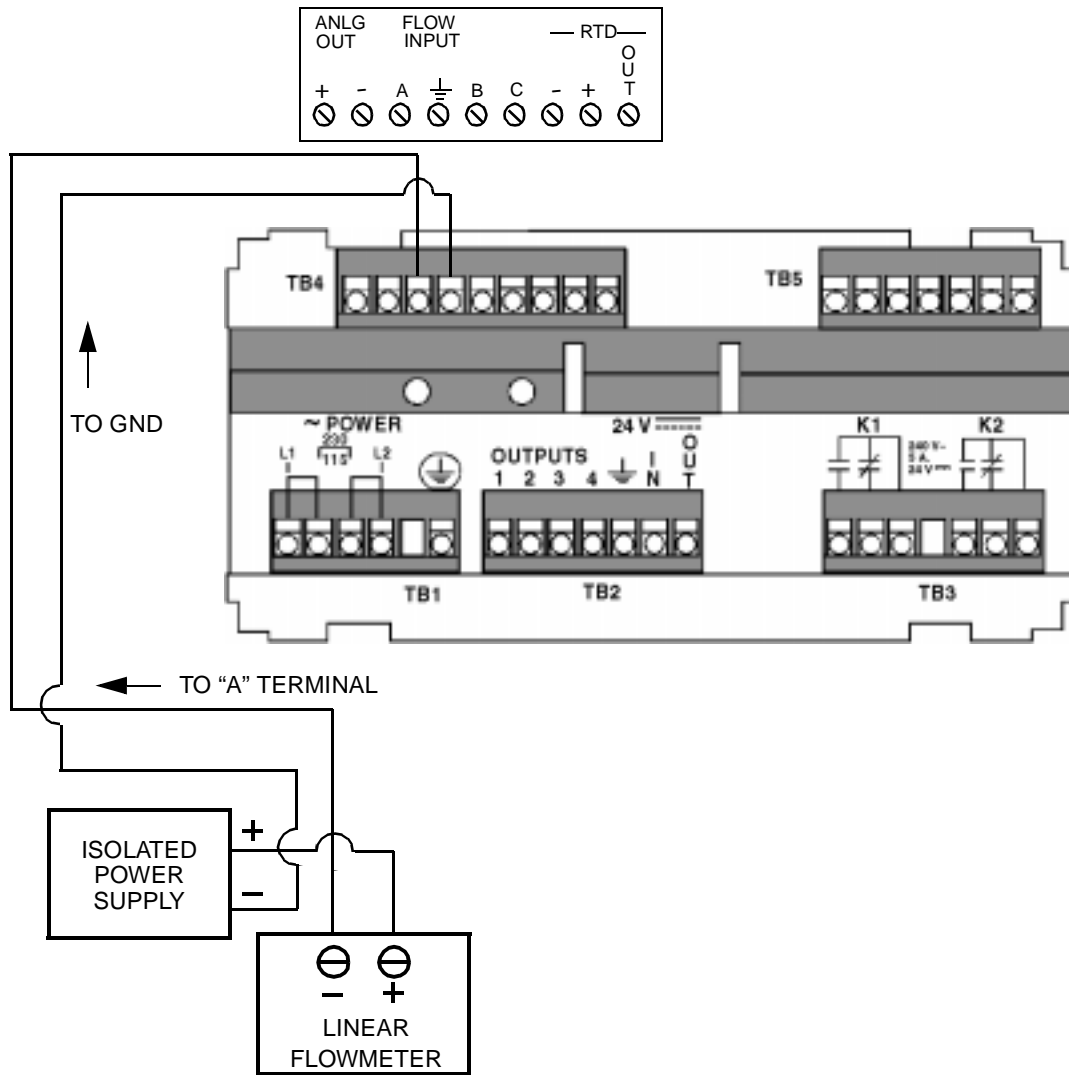

Figure 10. Analog Flow Input (External Power)

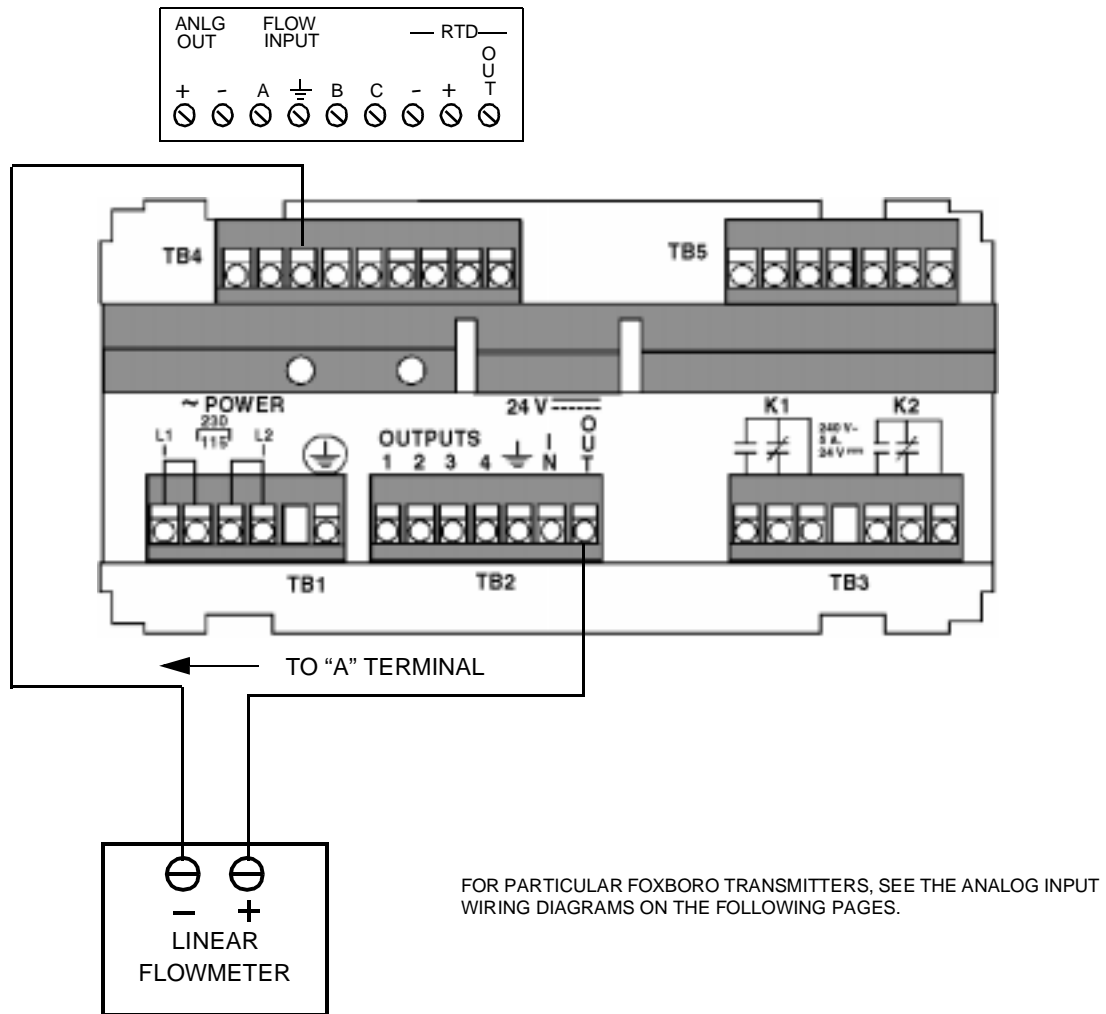

Figure 11. Analog Flow Input with 75LBA Powering Loop

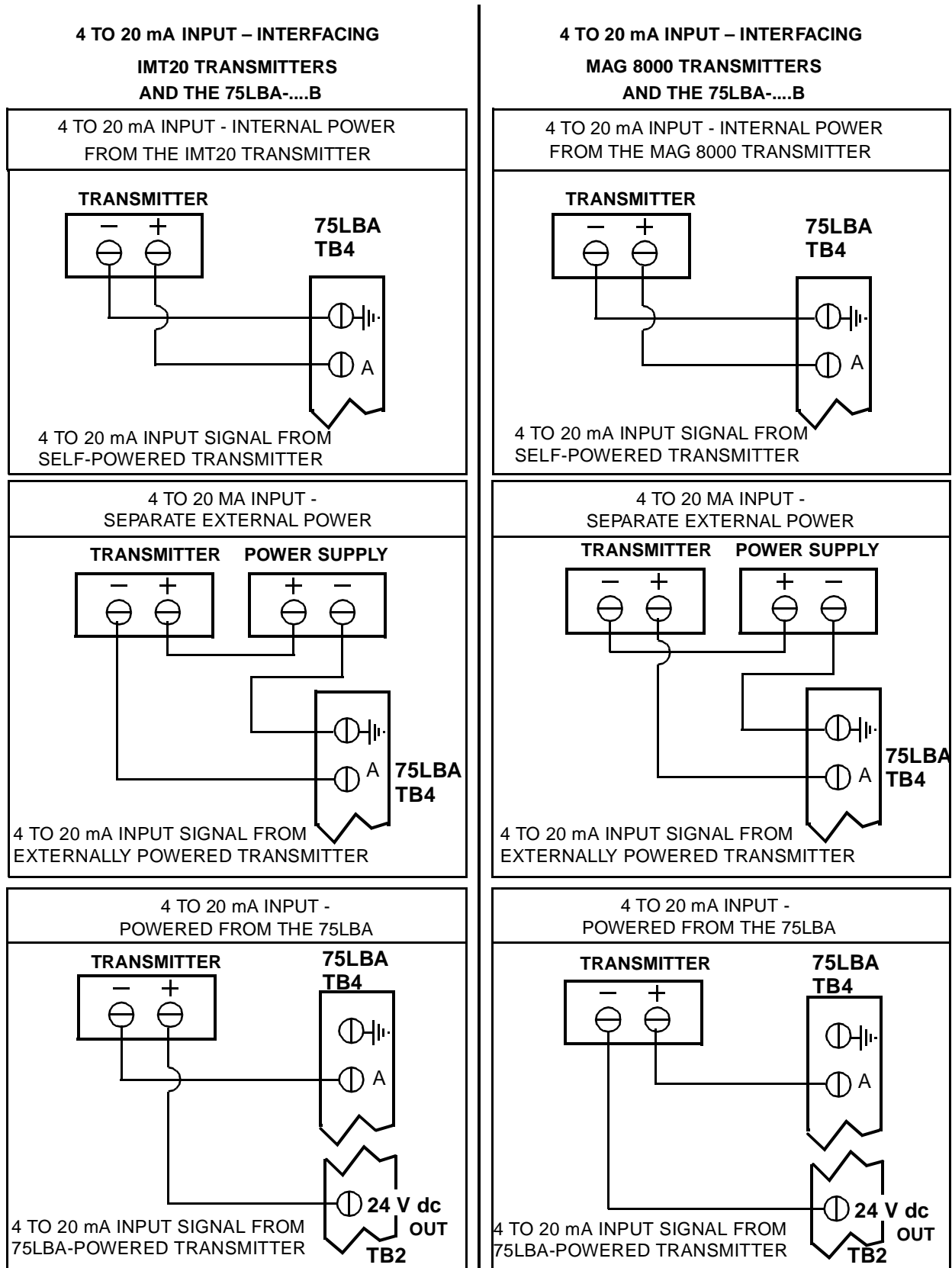

Figure 12. 4 to 20 mA Flow Input — Interfacing with IMT20 or MAG 8000 Transmitters

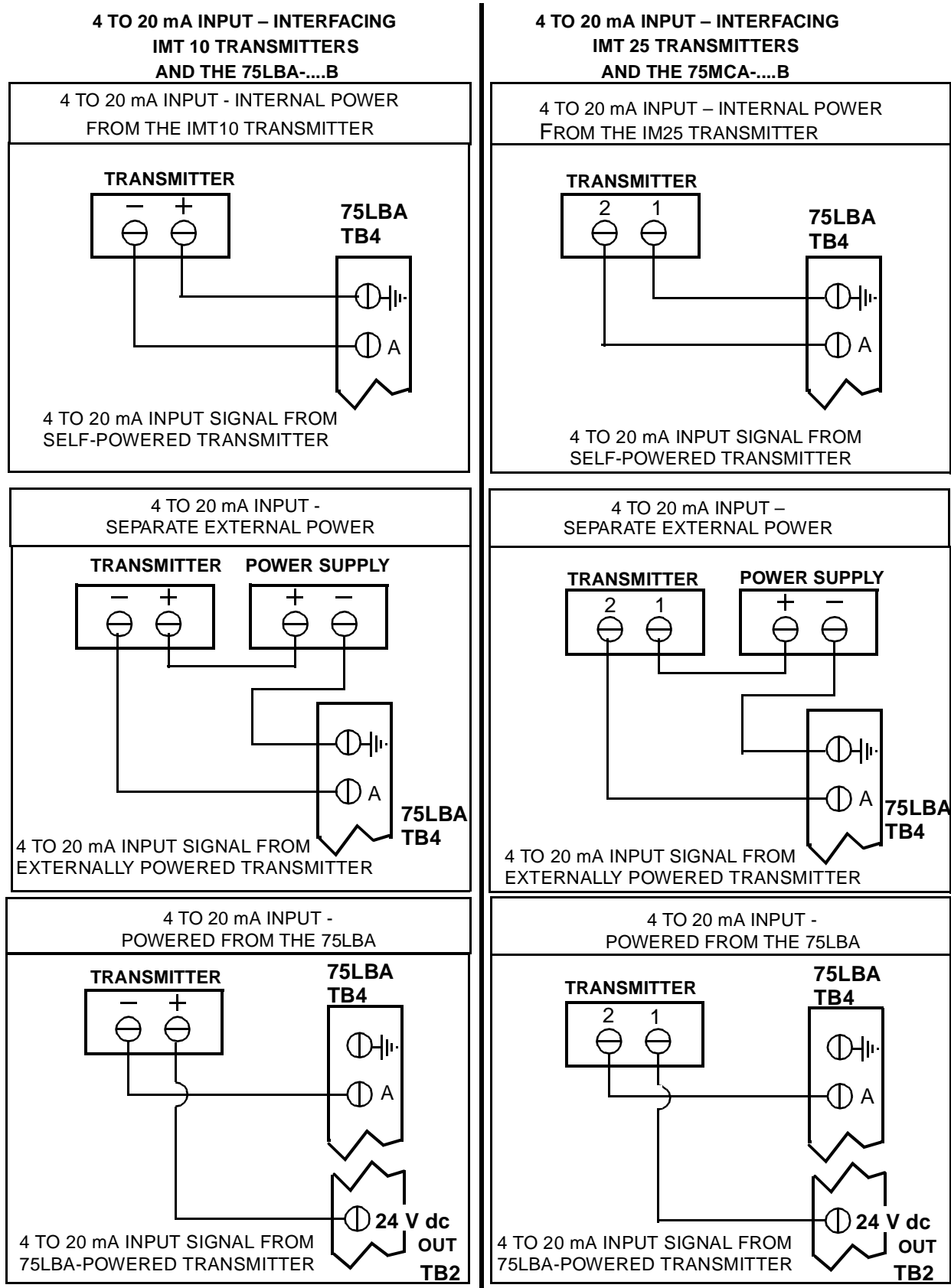

Figure 13. 4 to 20 mA Flow Input — Interfacing with IMT10 or IMT 25 Transmitters

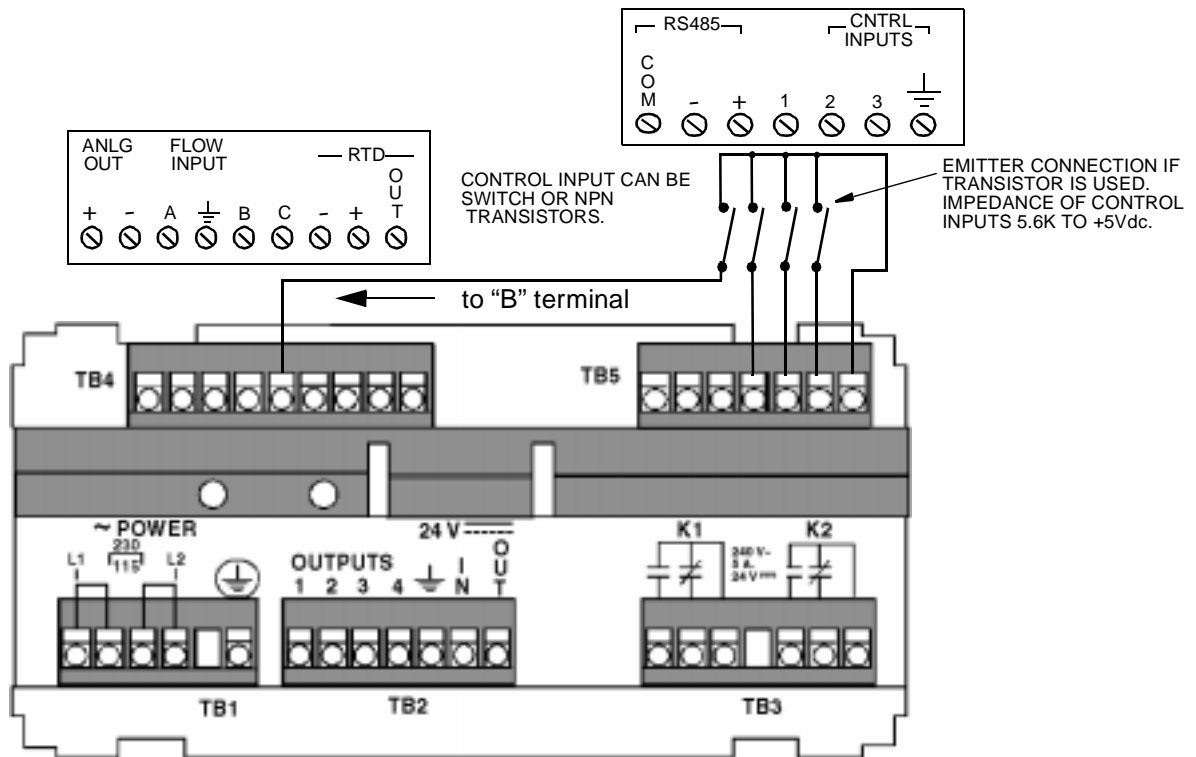
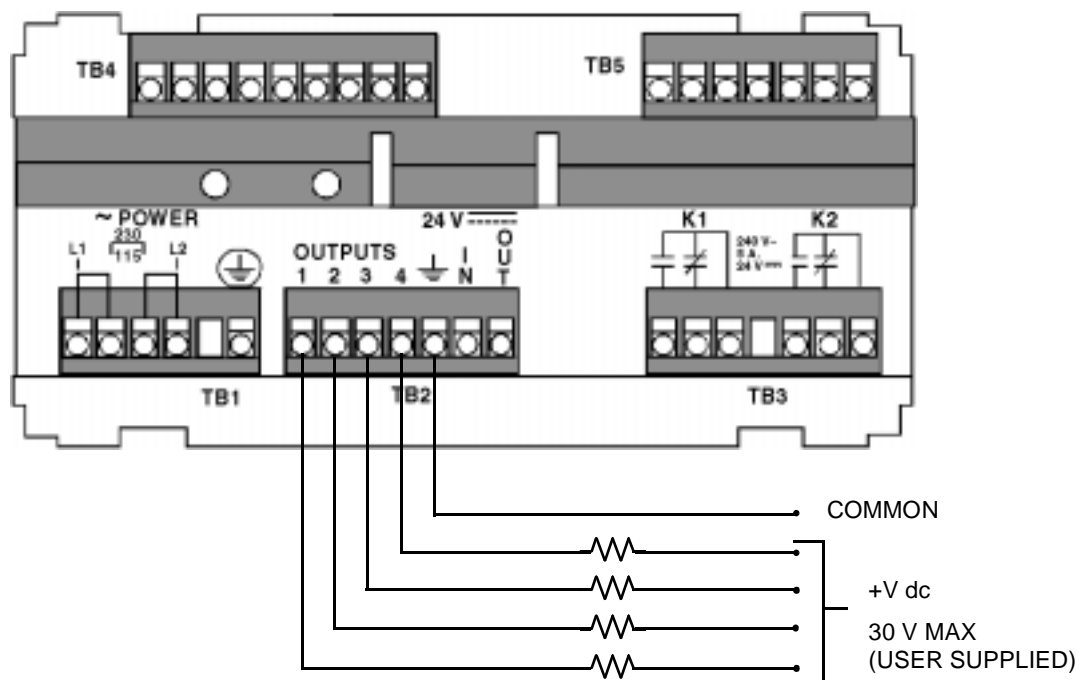

Figure 14. Control Inputs



LOADS MUST NOT DRAW MORE THAN 150 MA.

Figure 15. Wiring dc Loads to Digital Outputs

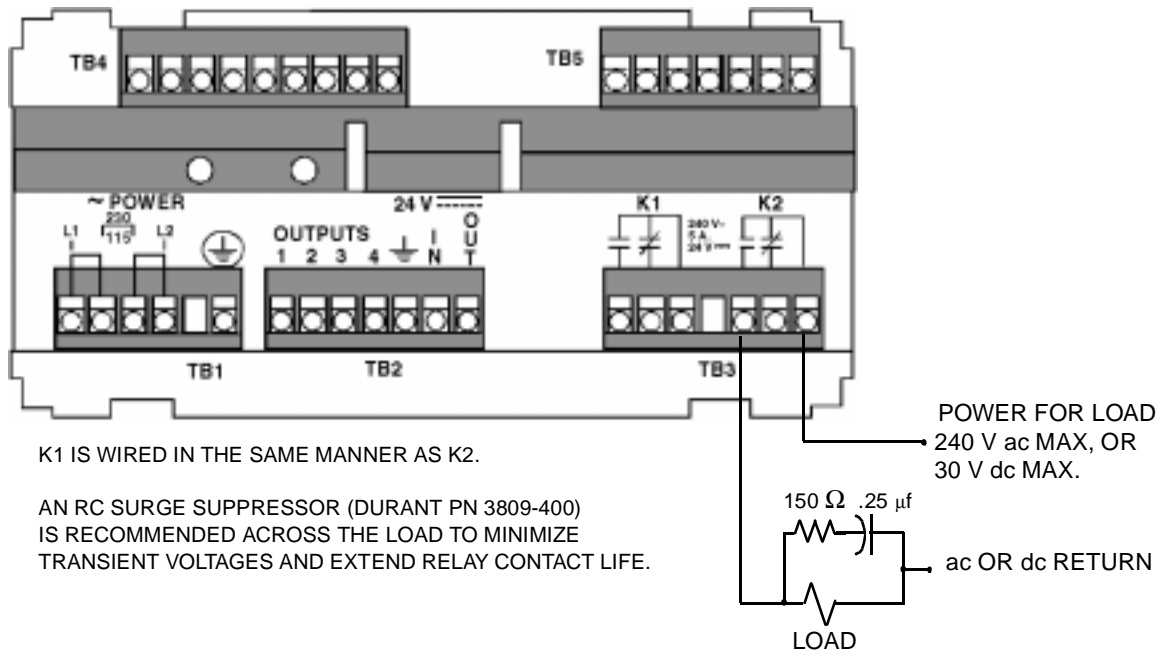

Figure 16. Relay Contact Output Wiring

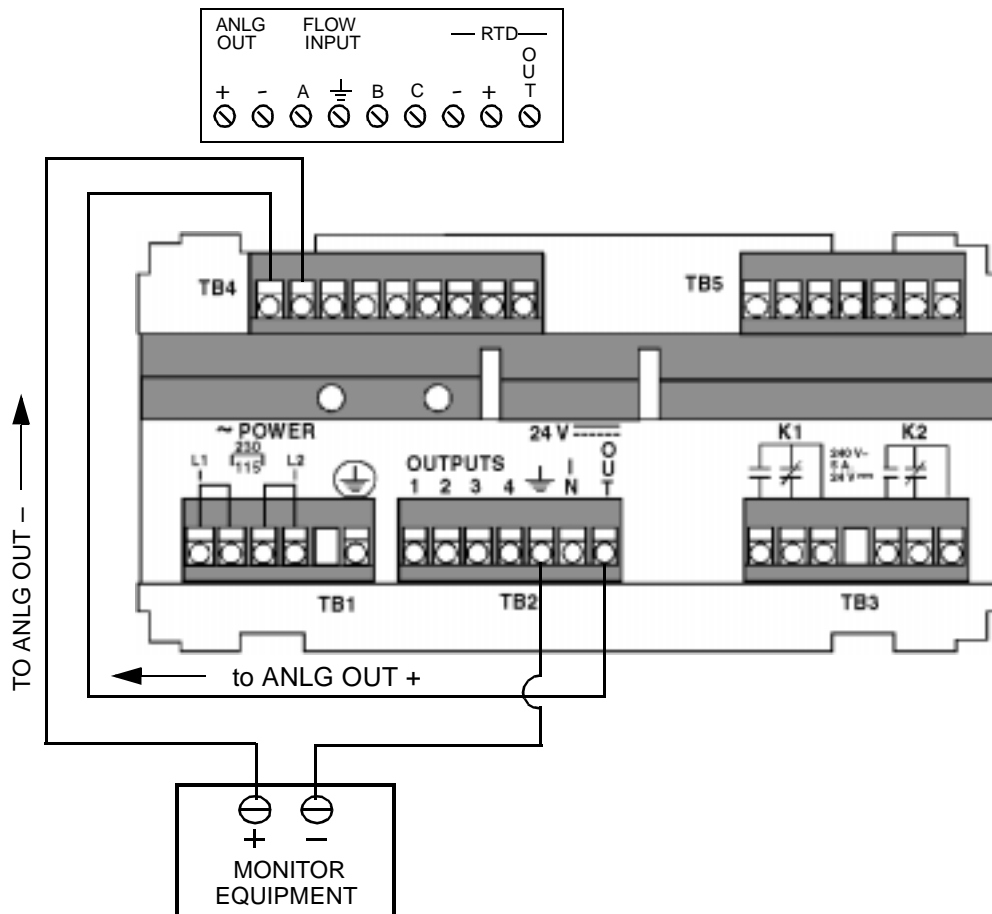

Figure 17. Analog Output (Internal Power)

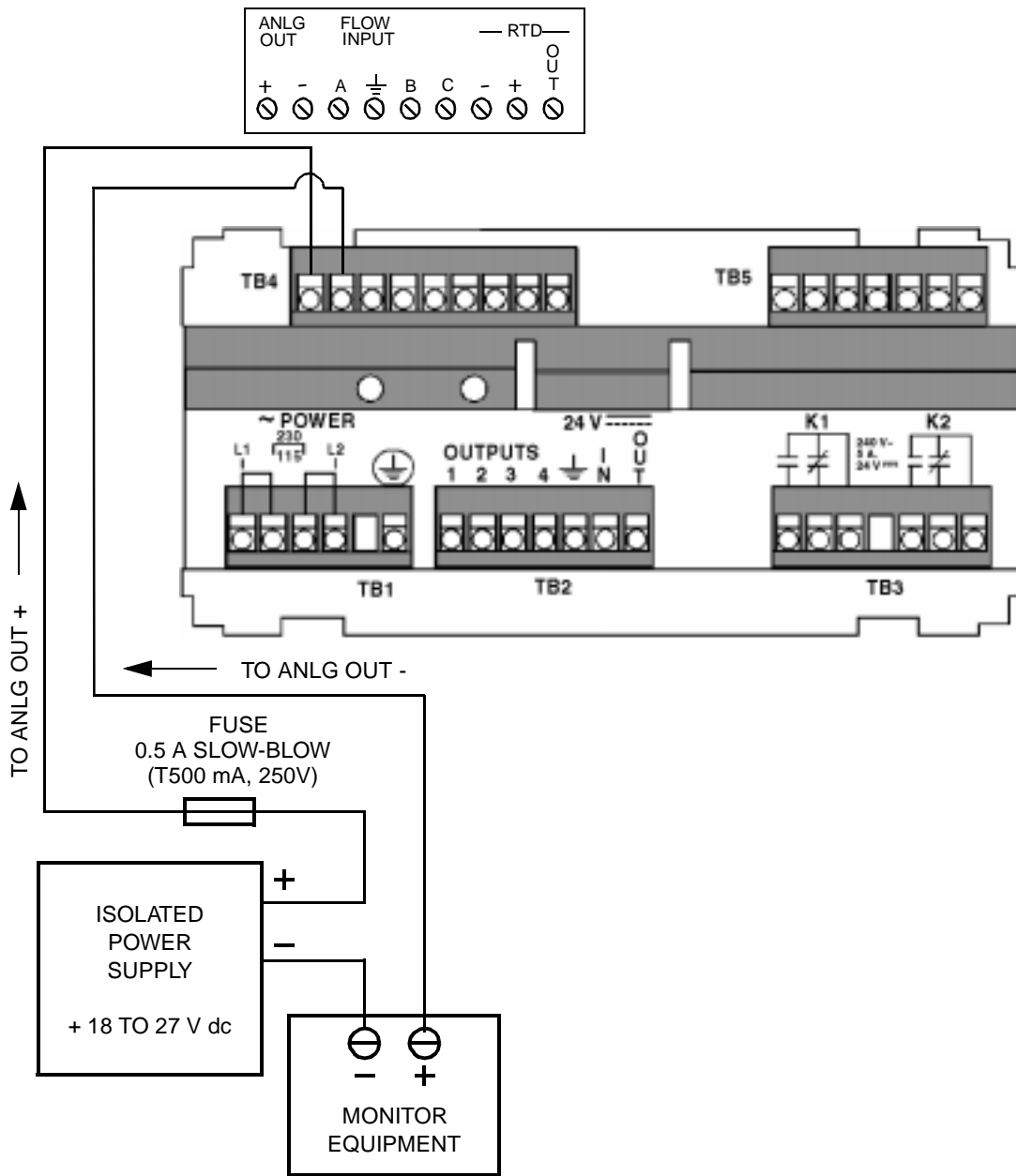

Figure 18. Analog Output (External Power)

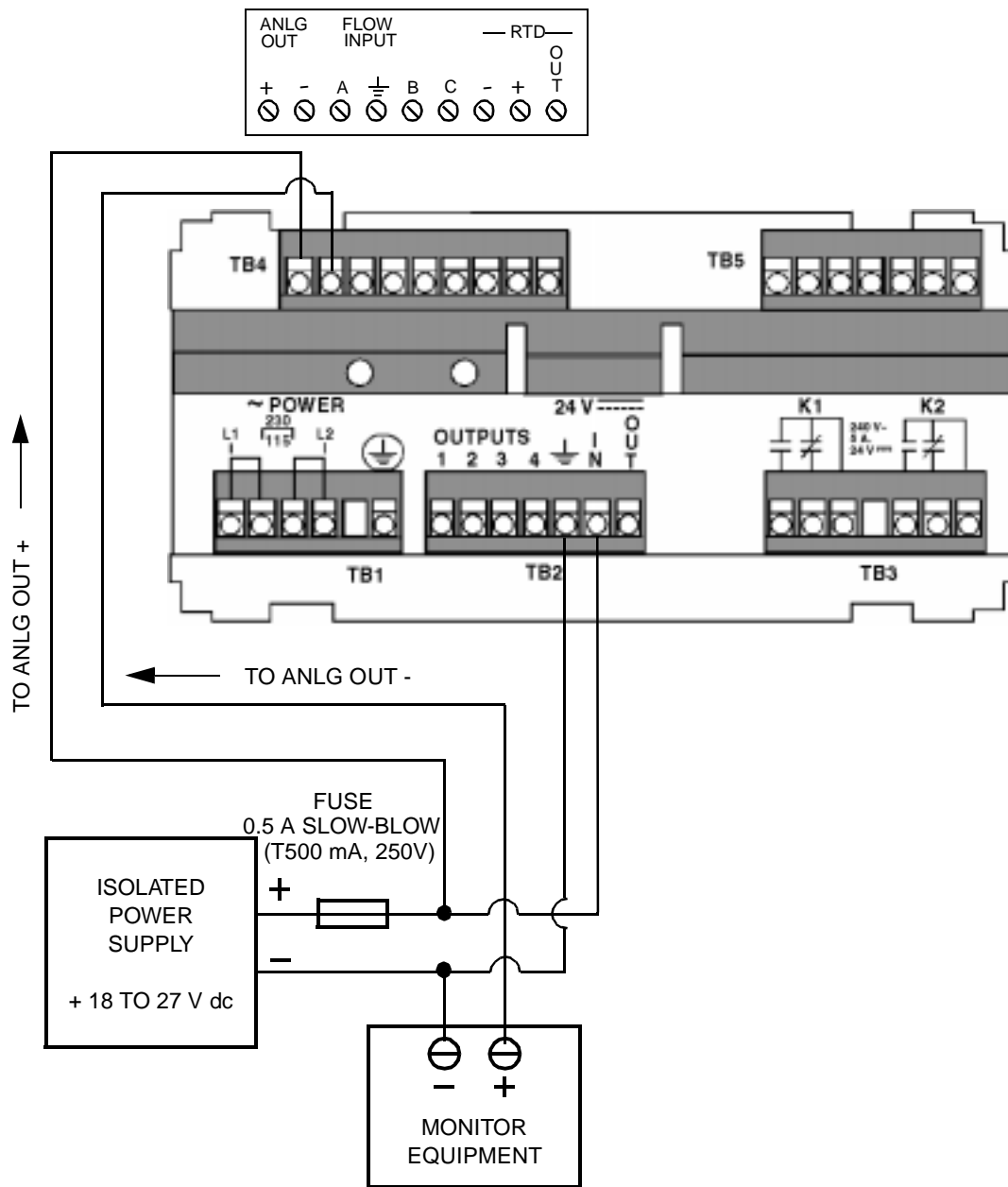

Figure 19. Analog Output (75LBA Powered by External 24 V dc)

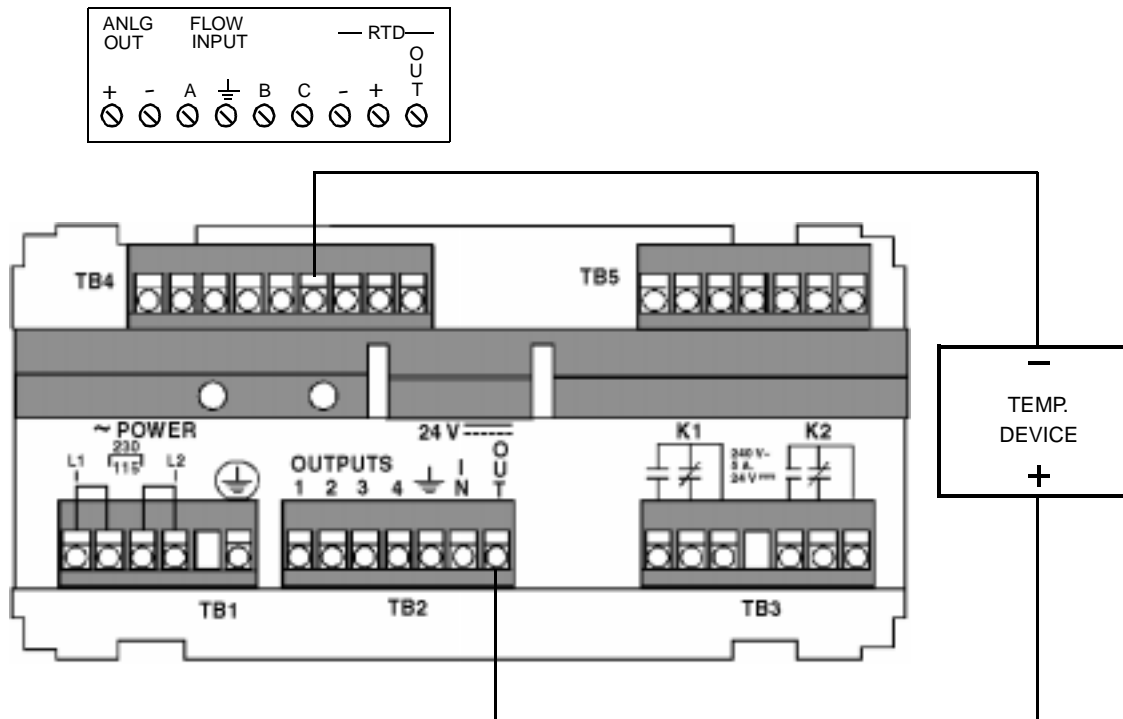

Figure 20. 4 to 20 mA Temperature Input (Internal Power)

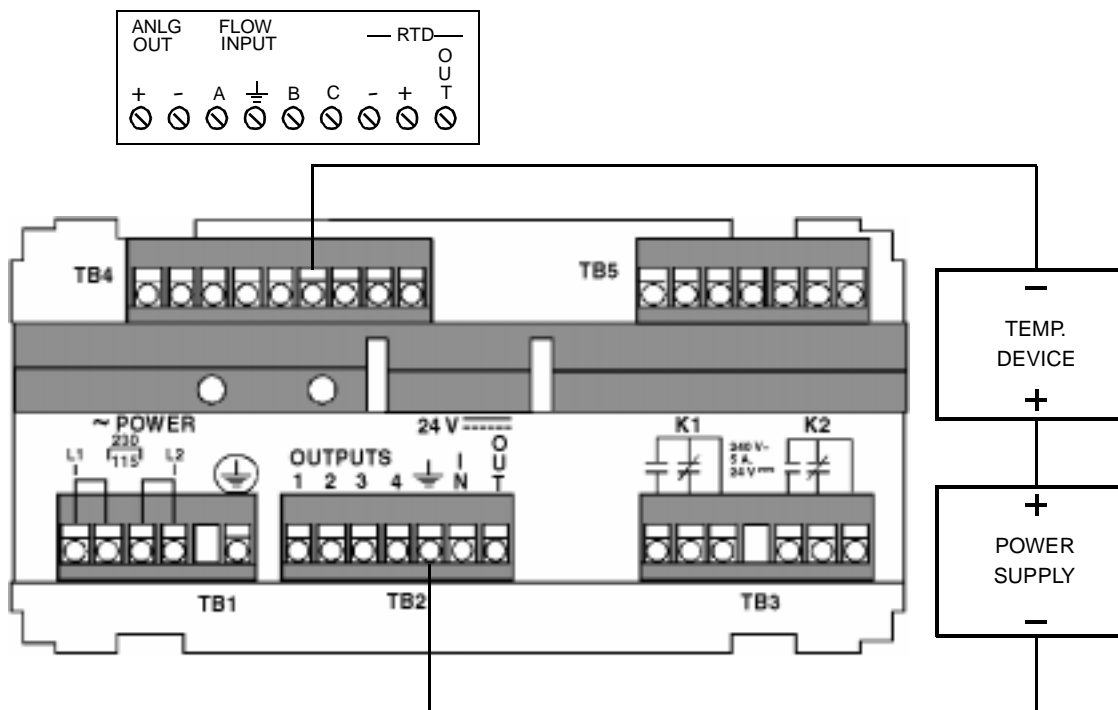

Figure 21. 4 to 20 mA Temperature Input (External Power)

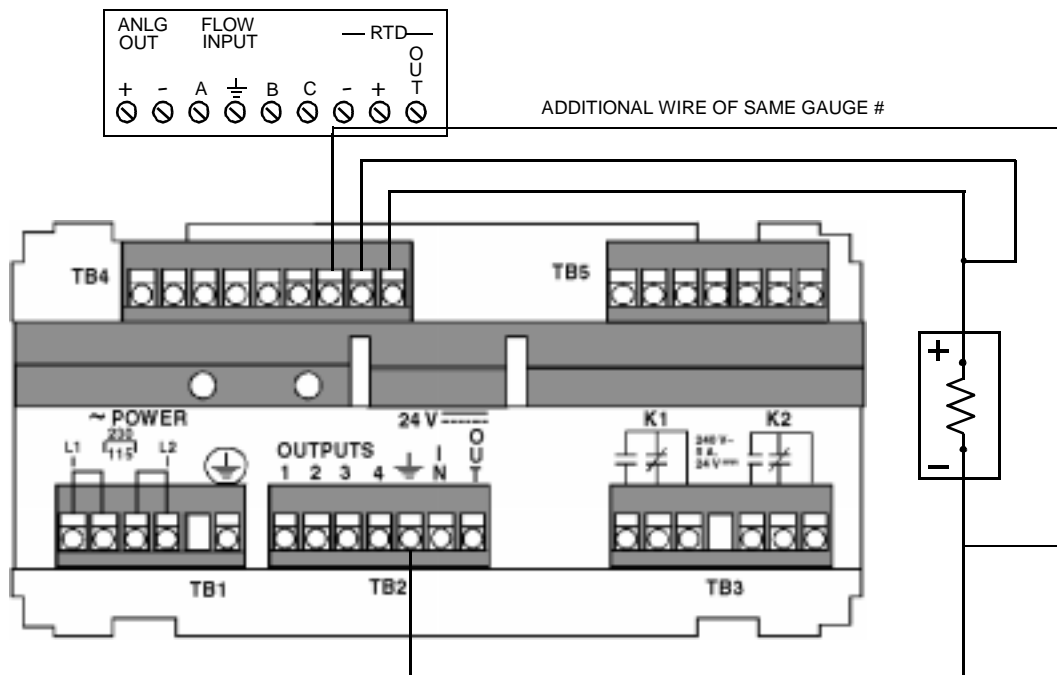

Figure 22. 3-Wire RTD Temperature Input

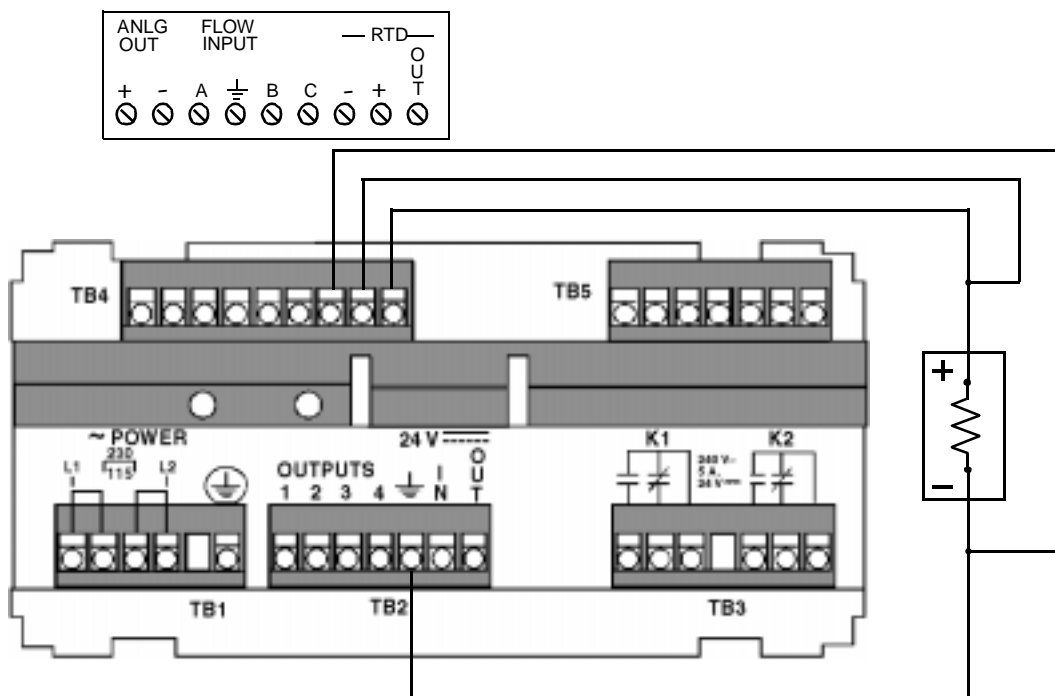

Figure 23. 4-Wire RTD Temperature Input



CAUTION: Care should be taken to avoid loss of RTD input as errors in measurement could result.

3. Configuration/Program Mode



CAUTION: Put control loop in manual before entering Program mode. All count and rate functions are inhibited when the unit is in Program mode.

NOTE: When the 75LBA-....B is first powered up, the message **CONFIGURE UNIT** appears on the display. Press the reset key to proceed with configuration and clear this message from the display.

Accessing Program Mode

To be configured, the unit must be placed in Program mode. Pressing the < and > keys at the same time causes the display to prompt the user for a **PASSWORD**. When the correct password is entered, the unit enters Program mode and displays the message **PROGRAM?**. The password is never displayed but an underscore is shown for each digit entered.

NOTE: The 75LBA-....B comes from the factory with a password of 000000. When the password is configured to all zeros, the unit enters the Program mode directly after pressing the < and > keys.

PROGRAM?

Configuration of the 75LBA-....B is done by stepping through a series of submenus. There are two ways to access menu and submenu items from the Program mode entry/exit display:

1. Scrolling with the arrow keys:
Press the ^ key to scroll through the main menu items (row X).
Press the < or > keys to scroll through the submenu items (column Y).
2. Entering an XY number in the Program display, where X and Y are the row (X) and column (Y) of the submenu desired as shown on the program menu chart on page 69.
This method provides direct access without scrolling with the arrow keys.

In some cases, submenus are layered (Z axis). Press the appropriate front panel number key to get to the desired layer from the top layer of the submenu. All submenus are described in detail following the program menu chart.

An important feature of the 75LBA-....B is the help key function. While in Program mode, the help key can provide detailed programming information. When the key is pressed, a message scrolls across the screen. You can pause or restart the message scroll for easy reading by

using the ^ key. You can abort the help message and return to programming by pressing any other key. A list of the help messages for the various programming blocks is included at the end of this section, beginning on page 66.

In any submenu of the Program mode, pressing the < and > keys at the same time returns the unit to the Program mode entry/exit display:

PROGRAM?

Pressing the Reset key at this time causes the unit to go to Run mode.

NOTE: When the 75LBA -....B is first powered up, the display blinks CONFIGURE UNIT. The unit is not preconfigured at the factory, and must be configured prior to startup. Once the unit is configured, this prompt will not appear again.

Key Functions

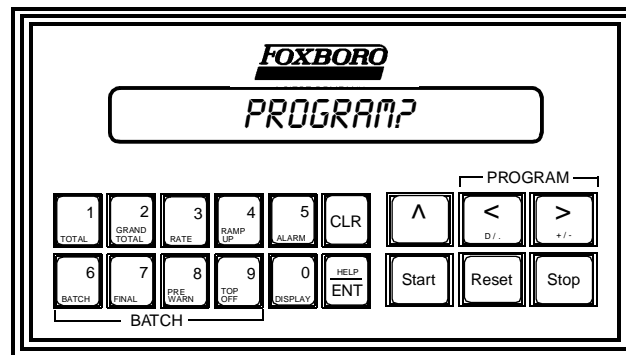

0
DISPLAY

to

9

Use to key in numerical values for parameters, or to select submenu block location when *PROGRAM?* prompt appears, or to select layered (Z axis) blocks within a submenu.

CLR

Use to clear the old parameter value from memory prior to keying in a new value.

ENT

Use to enter a new parameter value into memory.

HELP

Use to get help messages for any submenu. Press the ^ key to pause or restart message scroll for easy reading. Press any other key to abort message scroll and return to submenu block.

<
D/.

or

>

Use to scroll between submenus or to select a parameter or character shown in a submenu block. In most cases the selected parameter or character blinks. Also use to adjust current trim.

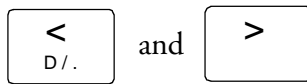

Press simultaneously to enter Program mode from Run mode or to return to the *PROGRAM?* prompt from any submenu.

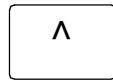

Use to:

- ◆ Scroll between menu rows when *PROGRAM?* or row indicator prompts appear.
- ◆ Select parameter options within a submenu.
- ◆ Pause or restart help message scroll.
- ◆ Change data pair numbers when entering temperature vs. density or frequency vs. K-factor curves.
- ◆ Press repeatedly to run diagnostics.

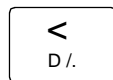

Use to enter decimal point when keying in some of the parameter values that use number keys.



Use to exit Program mode and enter Run mode when *PROGRAM?* prompt appears.

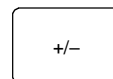

Use to indicate a negative value for temperature.

Row 1 Equations

Submenu 11 – Default Engineering Units (EGUs)

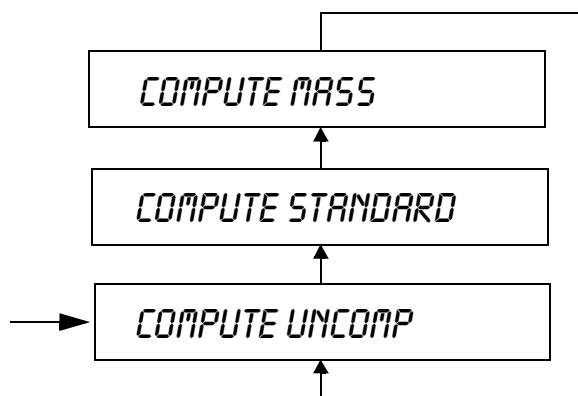

For Compensation of Rate/Total

Totals and rate can be displayed in compensated engineering units, standard or mass. Standard refers to volumetric measurement referenced to a standard temperature. Mass refers to volumetric measurements converted to mass units using the fluid density.

- ◆ Use the ^ key to select standard or mass.

Uncompensated Rate/Total

Running Total, Grand Total and Rate display/output will be in the EGU's and time base corresponding to the input rate. Running Total, Grand Total, and Rate display/output can be in other EGU's and time base by configuring the proper values in submenus 31, 32, 33, and 34.

- ◆ Use the ^ key to select uncomp (uncompensated).

Submenu 12 – Engineering Units

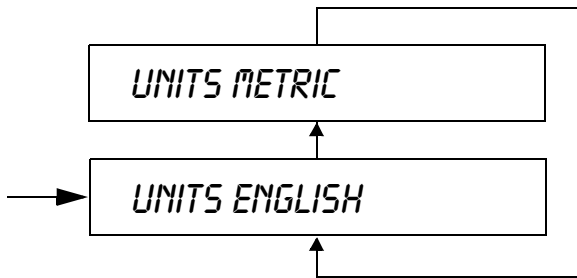

This submenu defines the default engineering units for total, rate, temperature, and density when total and rate are being compensated (that is, standard or mass selection in submenu 11). Go to the next submenu if uncomp was selected in submenu 11.

Unit	Metric	English
Volume	liter	gallon
Mass	kilograms	pounds
Density	kilograms per liter	pounds per gallon
Temperature	degrees Celsius	degrees Fahrenheit

English and Metric default EGU's cannot be mixed, either all English or all Metric EGU's must be used.

- ◆ Use the ^ key to select English or Metric.

Row 2 Cal. Inputs

Submenu 21 – Flow Input 4 to 20 mA Range

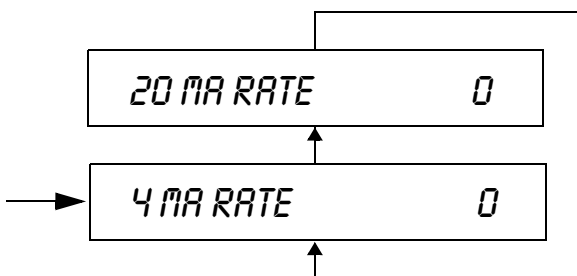

Configure the flow input current range at the 4 mA and 20 mA points.

1. Use the ^ key to select the 4 or 20 mA point.
2. Use the CLR key to erase an old value from memory.
3. Use keys 0 to 9 to enter the new value for the lower range (4 mA) or upper range value (20 mA).
4. Press ENT to write the new value into memory.

Uncompensated Rate/Totals

Uncomp was selected in submenu 11. The flow input can correspond to any desired EGUs. The time base must be in seconds, minutes, hours, or days. The totals and rate display/output can be in the same EGUs. The time base for the rate display/output is selected in submenu 34 and can be the same as or different from the time base for the rate input. Totals and rate can be displayed in other EGUs by configuring the proper values in submenus 31, 32, and 33.

Compensated Rate/Totals

Standard or mass was selected in submenu 11. The flow input must correspond to EGUs of gallons (English) or liters (Metric). The time base must be in seconds, minutes, hours, or days. The totals and rate display/output will be in the default EGUs selected in submenu 12. The time base for the rate display is selected in submenu 34 and can be the same as or different from the time base for the input rate. Totals and rate can be displayed in EGUs other than the default EGUs selected in submenu 12 by configuring the proper values in submenus 31, 32, and 33.

Submenu 22 – Input Rate Time Base

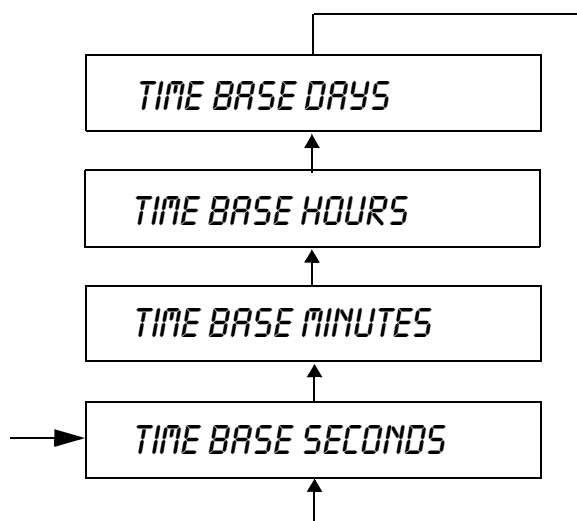

Select the time base corresponding to the flow input current.

- ◆ Use the ^ key to select seconds, minutes, hours or days.

Submenu 23 – Flow Input Calibration

NOTE: The 75LBA will not allow a 4mA input calibration current that is greater than 7mA, or a 20mA input calibration current that is less than 16mA. If the user tries to calibrate the input with current values outside of this range, the 75LBA display will read “Invalid Entry” for one second and not accept the value.

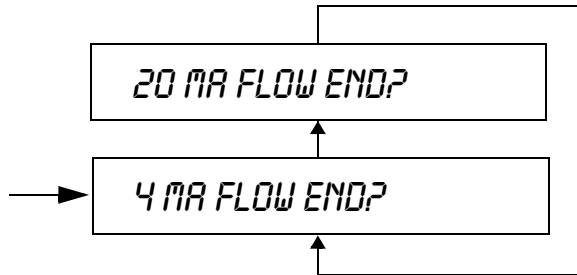

1. Input a 4 mA signal into the 75LBA-....B accurate to three decimal places and push RESET.
2. Use the ^ key to select 20 mA.
3. Input a 20 mA signal accurate to three decimal places and push RESET.

Skip this submenu if using the trim feature (submenu 37) to calibrate the analog flow input.

Submenu 24 – Flow Input Current Cut-Off Point

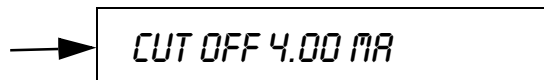

The flow input current cut-off point can be configured for any value between 4.00 and 10.00 mA. The analog output of the 75LBA-....B will be fixed at 4 mA while the input current has a value between 4 mA and the cut-off value.

1. Use the CLR key to enable entry of a new value.
2. Use keys 0 to 9 to enter a new value for the cut-off point.
3. Press ENT to write the new value into memory.

Submenu 25 – Temperature/Density Linearization Points

- ◆ Use < or > to cause T or D to blink.

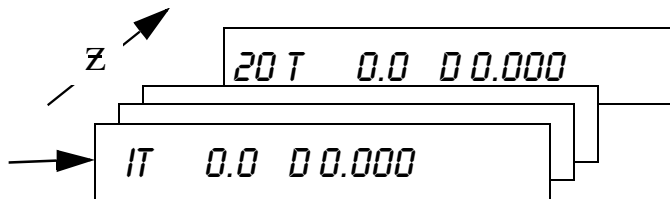

This submenu must be configured if total and rate are to be compensated (standard or mass selection in submenu 11). Go to the next submenu if uncomp was selected in submenu 11.

Density can be entered as a single, constant value, or can be linearized over a range of temperatures. The number at the far left of the display is the data pair number. Up to 20 data pairs can be entered. The data pairs do not need to be entered in any particular order.

1. Press the < or > keys to select temperature (T) or density (D). The T or D characters blink when that parameter is selected.
2. Push the CLR key to erase the old value from the memory.
3. Key in a new value using the number keys. The +/- key selects a negative value for temperature.

If English EGUs were selected in submenu 12, density must be entered as pounds per gallon, and temperature must be entered as degrees Fahrenheit. If Metric EGUs were selected, density must be entered in kilograms per liter, and temperature in degrees Celsius.

4. Push the ENT key to store the new value in memory.
5. Push the ^ key to select the next data pair number and repeat the process.

If temperature and density are assumed to be constant, enter a single value for density and temperature in the first data pair and go on to the next submenu.

Submenu 26 – Density at STP (Standard Temperature and Pressure)

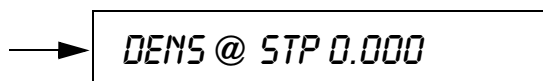

This block must be configured if standard was selected in submenu 11. Go to the next submenu if uncomp or mass were selected.

Enter the value for fluid density in pounds per gallon (English) or kilograms per liter (Metric) at reference temperature.

1. Push CLR to erase the old value from memory.
2. Key in a new value.
3. Press ENT to enter the new value into memory.

Submenu 27 – Temperature Input Selection

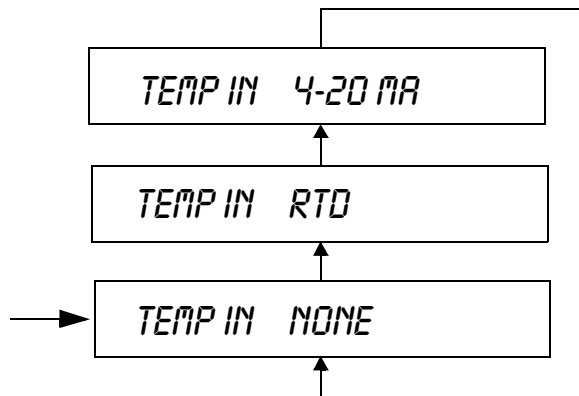

The user must supply an input for temperature to use the compensation feature (submenu 11), or must input a single value for density and temperature in submenu 25 if temperature is assumed to be constant. Temperature input can be configured as a 4-wire 100 ohm platinum RTD (to ASTM curve) or as a 4 to 20 mA current loop.

Select the None option if uncompensated rate/total is selected in submenu 11, or if temperature is considered to be constant when compensated rate/total is selected.

- ◆ Use the ^ key to select 4 to 20 mA, RTD, or None.

Submenu 28 – Temperature Input 4 to 20 mA Range

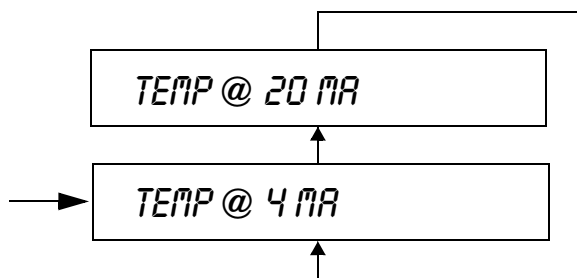

This submenu prompt appears only if the 4 to 20 mA current loop option was selected in submenu 27. The input current range for temperature is configured at the 4 mA and 20 mA points.

Temperature must be entered as degrees Fahrenheit if English was selected in submenu 12, or as degrees Celsius for Metric. Values for temperature can be entered in a range from -9999.9 to 9999.9.

1. Use the ^ key to select the 4 mA or the 20 mA point.
2. Press the CLR key to clear any old value for the 4 mA or 20 mA point from memory.
3. Key in a new value for temperature using the number keys, pressing the +/- key to indicate a negative value.
4. Press ENT to enter the new value into memory.

Submenu 29 – Analog Temperature Input Calibration

NOTE: The 75LBA-....B will not allow a 4mA input calibration current that is greater than 7mA, or a 20mA input calibration current that is less than 16mA. If the user tries to calibrate the input with current values outside of this range, the 75LBA-....B display will read "Invalid Entry" for one second and not accept the value.

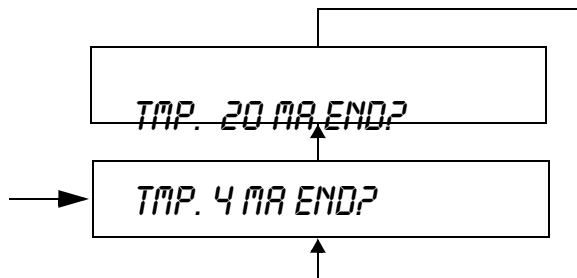

This submenu prompt appears only if the 4 to 20 mA current loop option was selected in submenu 27. Skip this submenu if you are using the trim feature (submenu 37) to calibrate analog temperature input.

1. Use the ^ key to select 4 mA.
2. Input a 4 mA signal, accurate to three decimal places, into the 75LBA-....B and push RESET.
3. Use the ^ key to select 20 mA.
4. Input a 20 mA signal, accurate to three decimal places, and push RESET.

Submenu 29 – RTD Temperature Input Calibration

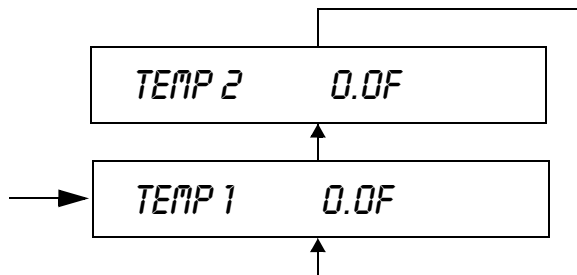

This submenu prompt appears only if the RTD option was selected in submenu 27.

1. Connect a known precision resistor to the RTD input.
2. Press the CLR key.
3. Enter the value of the temperature at that resistance, and press ENT. Temperature must be entered in degrees Fahrenheit if English was selected in submenu 12, or in degrees Celsius if Metric was selected.
4. The prompt display automatically goes to *TEMP 2* after the ENT key is pressed.

5. Connect a second known precision resistor to the RTD input. Press the CLR key.
6. Enter the value of the temperature at that resistance, and press ENT. The second temperature value must differ from the first by at least one degree.
7. The display returns to the *TEMP 1* prompt to indicate that calibration is complete.

Row 3 Cal. Output

Submenu 31 – Running Total C_2 Multiplier

→ C2 MULT 000000

The running total multiplier C_2 is configured in this submenu.

For Compensation (*STANDARD* or *MASS* selected in submenu 11)

If English was selected in submenu 12, the options for EGUs are standard gallons or pounds. The options are standard liters or kilograms if Metric was selected. By configuring the proper value for the multiplier, the user can totalize in engineering units other than the default EGUs. C_2 is the conversion factor between the desired EGUs and the default EGUs.

Example: It is desired that the running total display standard gallons x 100 (hundreds of gallons). Select standard in submenu 11, making standard gallons the default EGUs. C_2 is the conversion factor between the desired EGUs (standard gallons x 100) and the default EGUs (standard gallons). The value of C_2 is 0.01 (=1/100).

If C_2 is configured with a value of 1.0, the running total will be in the default EGUs selected in submenu 12.

Uncompensated Total (*UNCOMP* selected in submenu 11)

If C_2 is configured for a value of 1.00, the running total will be in the same engineering units as the input flow rate.

The running total can be displayed in other engineering units by configuring the proper value for C_2 .

Values for C_2 can range from 0.00001 to 999999. Common conversion factors are tabulated in Appendix A.

1. Push CLR to erase the existing value from memory.
2. Key in a new value with a decimal point.
3. Push ENT to enter the new value into memory.

Submenu 32 – Grand Total C_3 Multiplier

→ *C3 MULT 000000*

The grand total multiplier C_3 is configured in this submenu. See instructions for submenu 31.

Submenu 33 – Rate C_4 Multiplier

→ *C4 MULT 000000*

The rate multiplier C_4 is configured in this submenu.

For Compensation (STANDARD and MASS selected in submenu 11)

If English was selected in submenu 12, the options for default rate EGUs are standard gallons or pounds. If Metric was selected, the options are standard liters and kilograms. The time base for rate display/output is selected in submenu 35, and can be seconds, minutes, hours, or days.

By configuring the proper value for C_4 , rate can be displayed in other than the default EGUs. C_4 is the conversion factor between the desired EGUs and the default EGUs selected in submenu 12. See submenu 31 instructions for an example on how to determine the value of C_4 . If C_4 is configured with a value of 1.0, the rate will be in the default EGUs selected in submenu 11.

Uncompensated Rate (UNCOMP selected in submenu 11)

If C_4 is configured for a value of 1.00, the rate will be in the same engineering units as the input flowrate. The time base for the rate display/output is selected in submenu 34, and can be the same as or different from the input rate time base (submenu 22). For example, if Q_{input} is in gallons per minute, and a time base of hours was selected in submenu 34, rate would be displayed in gallons per hour if C_4 is configured as 1.00. The rate can be displayed in other engineering units by configuring the proper value for C_4 .

Values for C_4 can range from 0.00001 to 999999. Common conversion factors are tabulated in Appendix A.

1. Push CLR to erase the existing value from memory.
2. Key in a new value with decimal point.
3. Push ENT to enter the new value into memory.

Submenu 34 – Rate Time Base

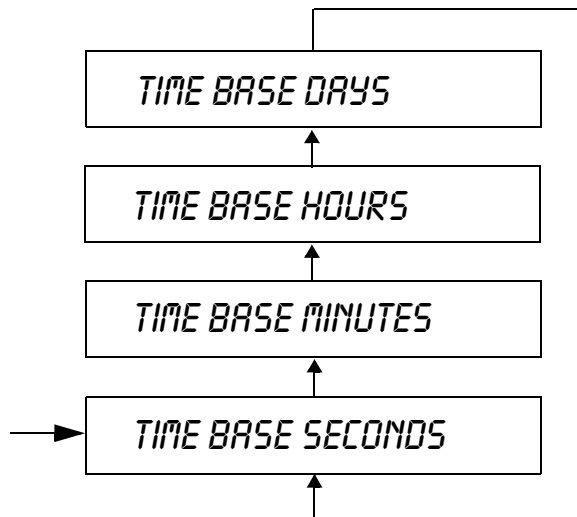

Select the desired time base for the rate display/output.

- ◆ Use the ^ key to select seconds, minutes, hours, or days.

Submenu 35 – Analog Output Parameter

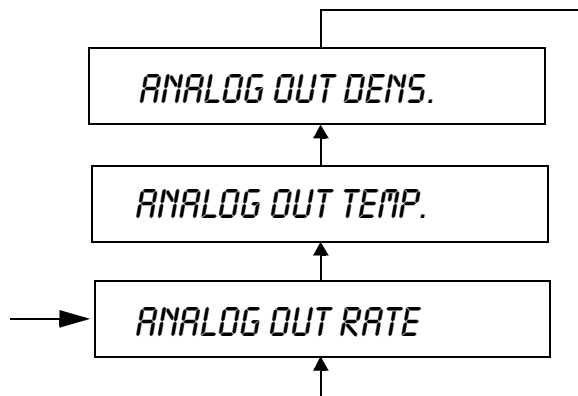

The 75LBA-....B provides an analog output that can be configured to represent rate, temperature, or density. The latter two may be configured only if temperature input or density linearization are being used.

1. Push the ^ key to select the desired parameter for the analog output.

NOTE: The analog output can be configured only for rate when uncomp is selected in submenu 11.

Submenu 36 – Analog Output Calibration

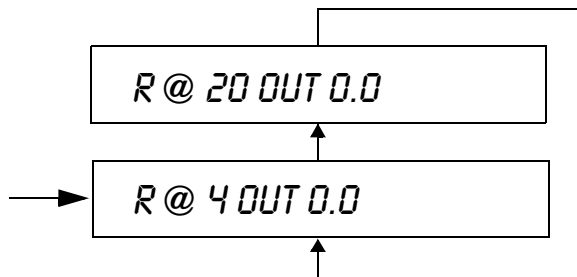

The character to the far left of the display confirms the parameter choice for the analog output made in submenu 35 (R for rate, T for temperature, and D for density). The current output is configured at the 4 mA and 20 mA points.

For compensation, rate lower and upper range values should be in the default EGUs selected in submenu 12 and the time base selected in submenu 34, or in EGUs based on the value entered for the rate multiplier in submenu 33.

When uncomp is selected in submenu 11, rate lower and upper range values should be in the same EGUs as the input rate in submenu 21 and the time base selected in submenu 34, or in EGUs based on the value entered for the rate multiplier in submenu 33.

Temperature lower range and upper range values should be in degrees Fahrenheit (English) or Celsius (Metric). Density lower range and upper range values should be in pounds per gallon (English) or kilograms per liter (Metric).

1. Use the ^ key to select the 4 mA point.
2. Press CLR to erase the existing value for 4 mA point from memory.
3. Key in a new value.
4. Press ENT to enter this new value into memory.
5. Use the ^ key to select the 20 mA point and repeat the process.

Submenu 37 – Analog Output Trim

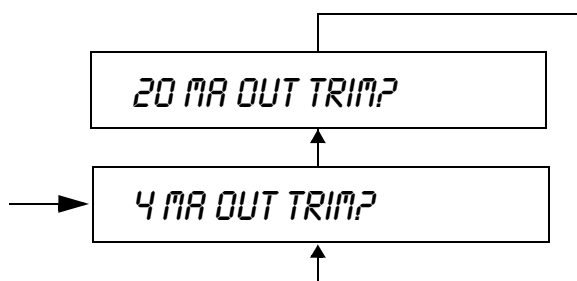

1. With the power turned off, connect the (+) and (-) terminals of the analog output as indicated in the diagrams below.
2. Turn the power back on.
3. Press CLR to start the trim process for the 4 mA output.

4. Use the < or > keys to adjust current to 4 mA if necessary.
5. Press the ENT key to set the 4 mA trim.
6. Use the ^ key to select the 20 mA point.
7. Press CLR to start the trim process.
8. Use the < or > keys to adjust the 20 mA if necessary.
9. Press the ENT key to set the 20 mA trim.

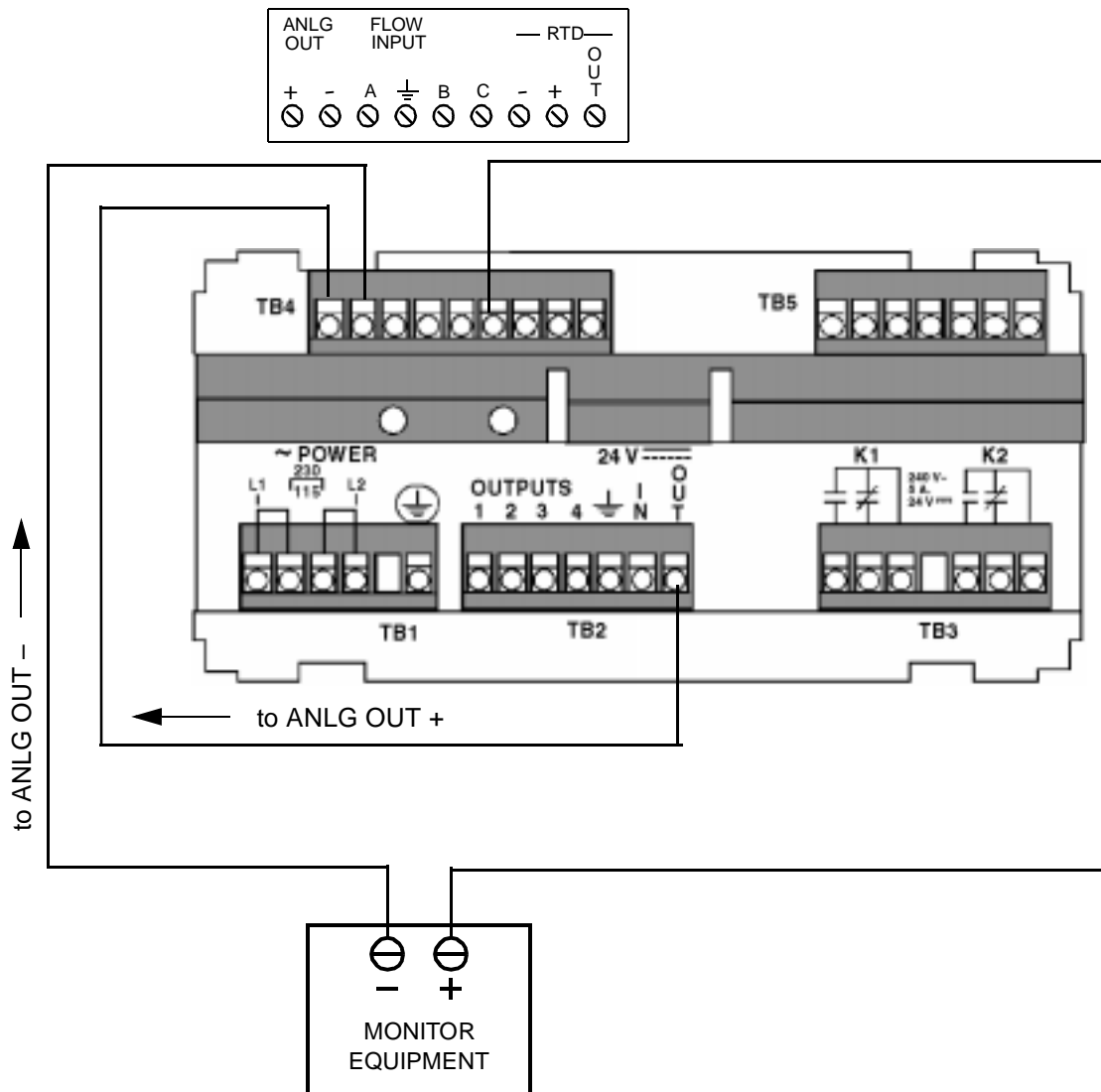
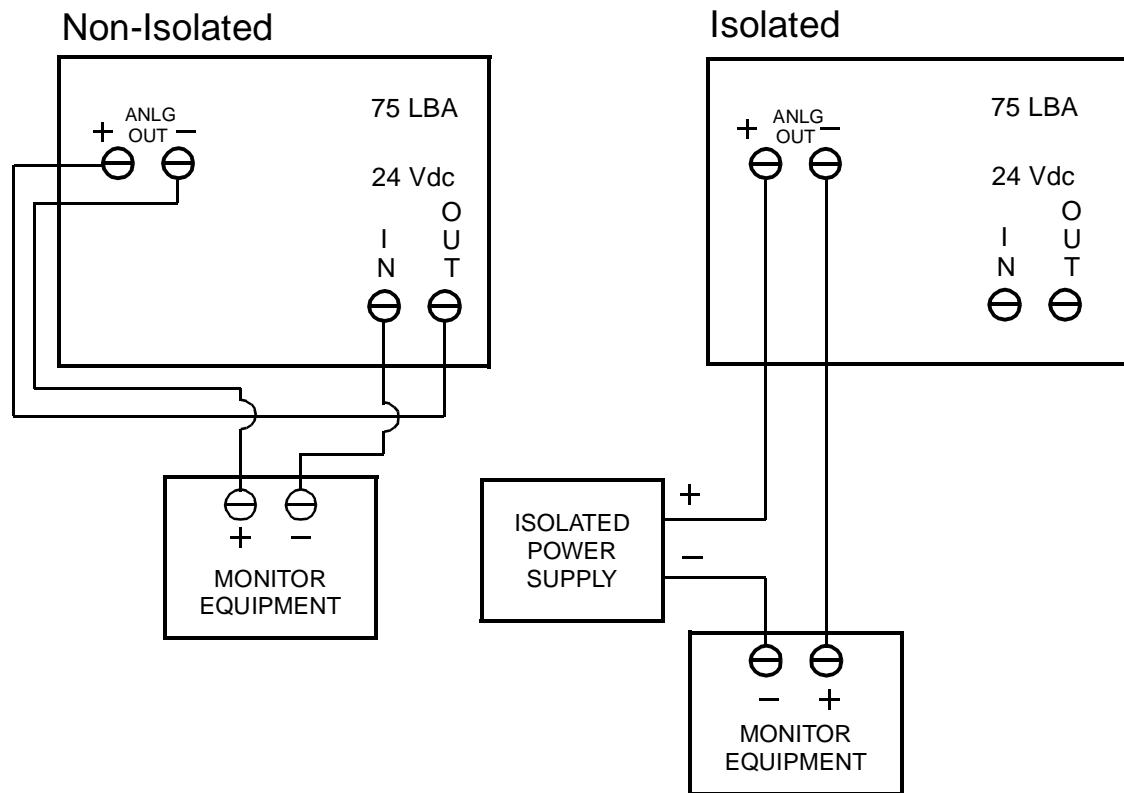

Figure 24. Temperature Input Trim (Internal Power)



The Analog Output Trim feature can be used to perform the calibration of the analog inputs described in submenus 23 and 29.

With the power off, connect the analog output to the flow temperature analog input terminals with a DVM wired in series in the loop. See Figure 24.

1. Turn the power on and press CLR to start the trim process for the 4 mA output.
2. Use the < or > keys to adjust the current until the DVM reads 4.000 mA.
3. Press the RESET key to calibrate the input.
4. Select the flow or temperature input loop (1 for flow or 2 for temperature).
5. Press the ENT key to set the 4 mA trim.
6. Use the ^ key to select the 20 mA point.
7. Press CLR to start the trim process.
8. Use the < or > keys to adjust the current until the DVM reads 20.000 mA.
9. Press the RESET key to calibrate the input.
10. Select the flow or temperature input loop (1 for flow or 2 for temperature).
11. Press the ENT key to set the 20 mA trim.

Row 4 Totalizer

Submenu 41 – Running Totalizer Scaled Pulse Output

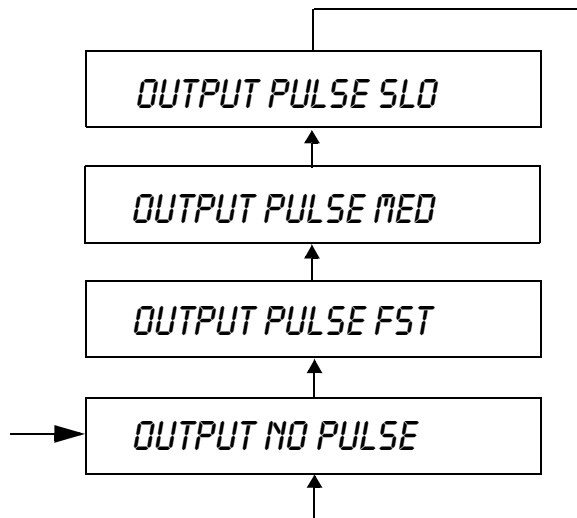

Transistor output T_4 provides a totalizer pulse output for remote totalization that is coincident with the least significant whole digit of the running total display. The pulse output can be configured for fast, medium, or slow pulse widths. It can also be configured to not output pulses.

- ◆ Fast – 125 μ sec on, 1500 Hz maximum frequency
- ◆ Medium – 2 msec on, 200 Hz maximum frequency
- ◆ Slow – 50 msec on, 10 Hz maximum frequency
- ◆ No Pulse – Off continuously

This output has a 255-count buffer. The buffer is saved at power down, or if the totalizer is reset.

- ◆ Use the ^ key to select the mode of operation: no pulse, fast, medium, or slow.

Submenu 42 – Running Total Decimal Point

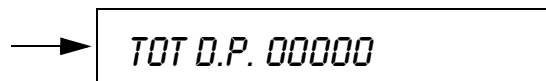

The running totalizer display can have a decimal point configured in any of five positions to give the desired degree of resolution.

- ◆ Use keys 0 to 4 to select the desired position of the decimal point: press 0 for no decimal point, press 1 for display of tenths, and so on.

Submenu 43 – Grand Total Decimal Point

→ G. TOT. D.P. 00000

The grand totalizer display can have a decimal point configured in any of five positions to give the desired degree of resolution.

- ◆ Use keys 0 to 4 to select the desired position of the decimal point: press 0 for no decimal, press 1 for display of tenths, and so on.

Submenu 44 – Running Total Label

→ TOT. LABEL ***

An alphanumeric label can be configured to indicate the EGUs for the running total. The label can consist of up to 3 characters. Enter *** or 3 spaces if no label is desired. This label is displayed along with the running total when the proper key is pressed while in Run mode.

1. Use the < or > keys to cause a character to blink on the display.
2. Then press the ^ key to scroll through the alphanumeric characters. Available characters are A–Z, 0–9, “/”, “*” and space.
3. Repeat steps 1 and 2 for all three positions.

Submenu 45 – Grand Total Label

→ G. TOT. LABEL ***

An alphanumeric label can be configured to indicate the EGUs for the grand total. The label can consist of up to 3 characters. Enter *** or 3 spaces if no label is desired. This label is displayed along with the grand total when the proper key is pressed while in Run mode.

1. Use the < or > keys to cause a character to blink on the display.
2. Then press the ^ key to scroll through the alphanumeric characters. Available characters are A–Z, 0–9, “/”, “*” and space.
3. Repeat steps 1 and 2 for all three positions.

Submenu 46 – Batch Parameter Key Locks

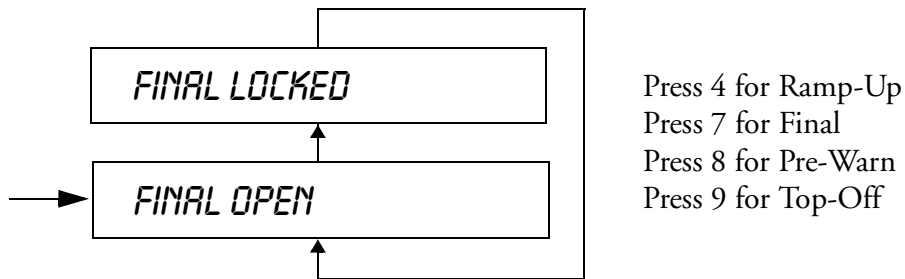

The following batching parameter values can normally be changed while the unit is in Run mode:

Ramp-Up	Key 4
Final	Key 7
Pre-Warn	Key 8
Top-Off	Key 9

If desired, the user can configure these keys to be locked while in Run mode. When a key is locked, changes in that parameter's value cannot be made in Run mode.

To change a parameter value on a locked key you must first enter Program mode, giving a password if one is set, and unlock the key. You then exit to Run mode to change the parameter value.

1. Push key 4, 7, 8, or 9 to select a key parameter. The parameter represented by that key appears in the display prompt.
2. Push the ^ key to select open or locked.

NOTE: A value must be entered for a parameter in Run mode, prior to locking the key in Program mode.

pressed while in Run mode. The label can consist of up to 3 characters. Enter *** or three spaces if no label is desired.

1. Use the < or > keys to cause a character to blink on the display.
2. Then press the ^ key to scroll through the alphanumeric characters. Available characters are A–Z, 0–9, “/”, “*” and space.
3. Repeat steps 1 and 2 for all three character positions.

Row 6 I/O

Submenu 61 – Alarm Output Configuration

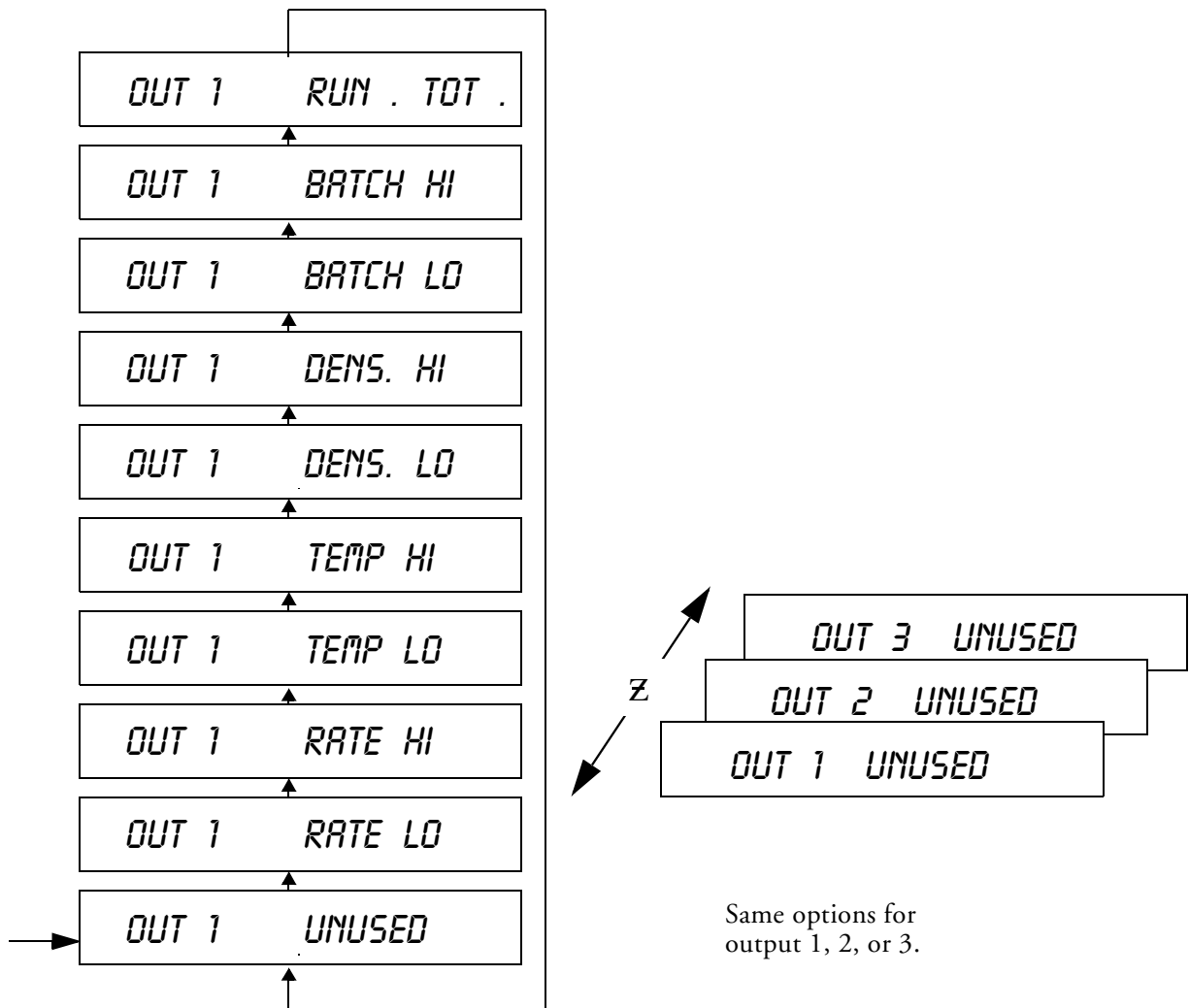

The 75LBA-....B is equipped with three alarm outputs. Each alarm output can be configured to perform one function from this list:

- ◆ Unused
- ◆ Rate Low
- ◆ Rate High
- ◆ Temperature Low
- ◆ Temperature High
- ◆ Density Low
- ◆ Density High
- ◆ Batch Total Low
- ◆ Batch Total High
- ◆ Running Total

Alarm output configuration can be recorded in the chart on page 64.

1. Press 1, 2 or 3 to select outputs 1, 2 or 3. The output number is shown in the display when the number key is pressed.
2. Use the ^ key to scroll through the function options listed above.

Submenu 62 – Alarm Output Labels

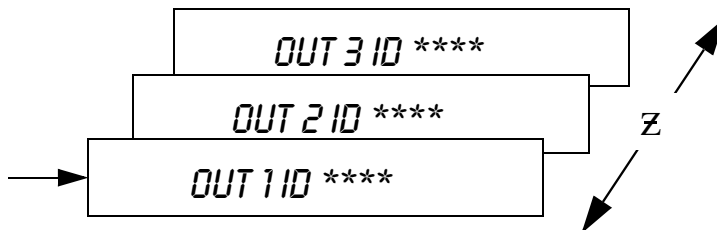

An alphanumeric label can be configured for each alarm output to indicate the function being performed more clearly. These labels are shown on the display in Run mode when key 5 is pressed. The alarm outputs remain labeled output 1, output 2, and output 3 in the configuration blocks.

Enter **** or four spaces if no label is desired.

1. Press 1, 2, or 3 to select outputs 1, 2, or 3. The output number is shown on the display when the number is pressed.
2. Use the < or > keys to cause a character to blink on the display.
3. Then press the ^ key to scroll through the alphanumeric characters. Available characters are A–Z, 0–9, “/”, “*” and space.
4. Repeat steps 2 and 3 for all four character positions.

Submenu 63 – Alarm Output Timeout

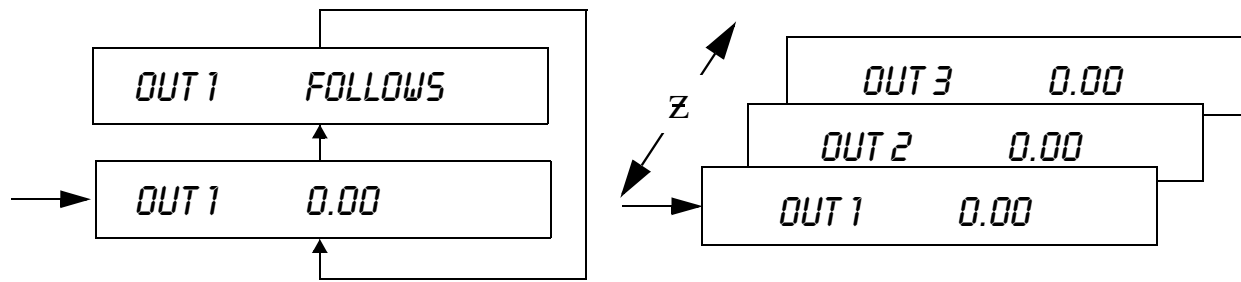

Every alarm function can be configured to time out, latch or follow.

Timeout

In this mode, the alarm output is energized when the corresponding parameter value reaches the alarm point value. The alarm stays energized for a configured time from between 0.01 and 99.99 seconds. After the alarm time expires, the alarm de-energizes, or re-energizes for another time period, depending on the comparison of the parameter value with the alarm point value.

1. Press 1, 2, or 3 to select outputs 1, 2 or 3. The output number is shown on the display after the number key is pressed.
2. Press CLR to erase the old alarm time from memory.
3. Key in a new time value between 0.01 and 99.99.
4. Press ENT to enter this new value into memory.

Latch

The output is configured to latch by entering a time value of 0.00 in step 3 above. Once energized, the alarm output remains energized until unlatched by pressing the Reset key and/or by activating a control input configured for this function.

Follows

Alarms for rate, temperature, and density can also be configured for follows. In this mode, the alarm output is energized when the parameter value reaches the alarm point value. The output automatically de-energizes when the latest parameter update value no longer triggers the alarm. The duration of time the output remains energized depends on the comparison of the updated parameter value with the alarm point value.

- ◆ Select *FOLLOWS* by pressing the ^ key.

Submenu 64 – Run Mode Alarm Point Key Lock

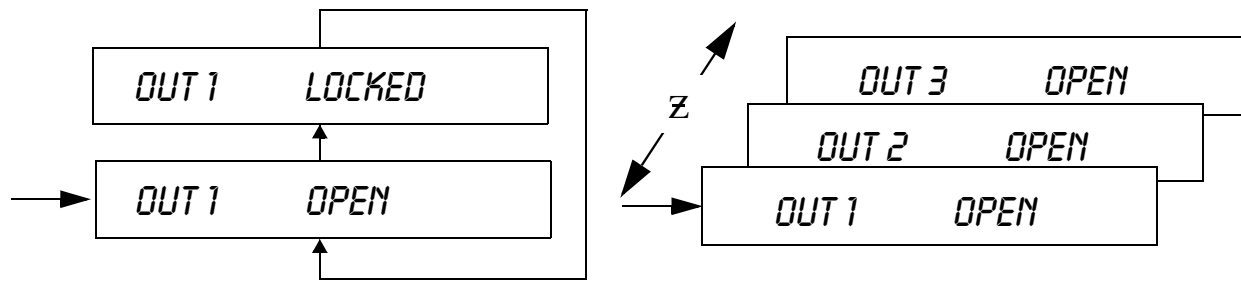

Alarm point values can be changed while in Run mode by pressing key 5 (Alarm) and the ^ key. You can configure these changes to be locked, selectively for each output.

When an alarm point is locked, changes to its value can be made in Run mode. The user must first enter Program mode, giving a password if one is set, and unlock the key. Then the user exits Program mode and changes the alarm point value in Run mode.

1. Push key 1, 2, or 3 to select output 1, 2, or 3. The output number is shown on the display after the number key is pressed.
2. Push the ^ key to select open or locked for each output number.

Submenus 65, 66, 67, 68 – Control Inputs 1, 2, 3, B Functions

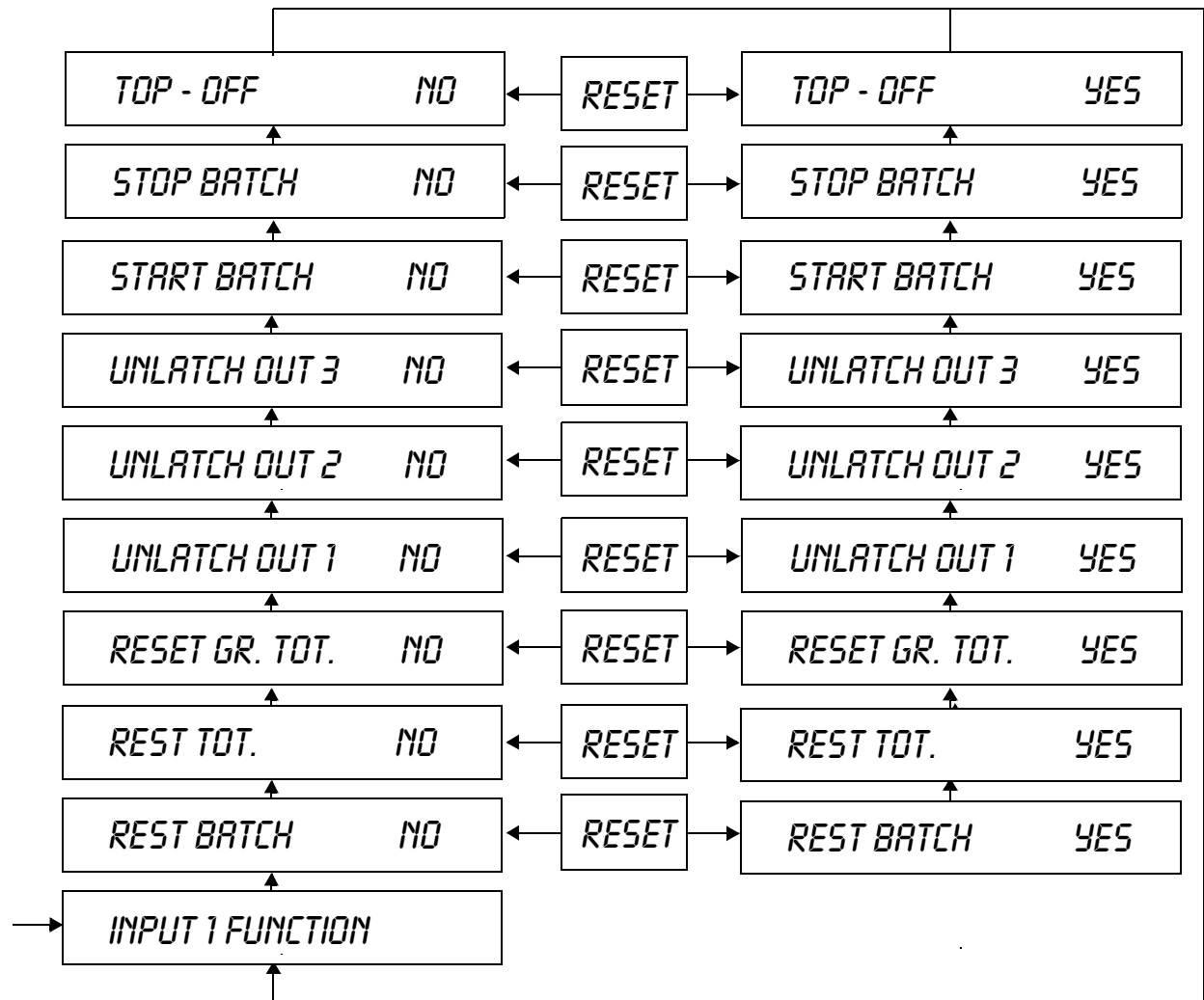

Control Inputs can be configured to perform one or more of the following functions:

- ◆ Reset Batch Total
- ◆ Reset Running Total
- ◆ Reset Grand Total
- ◆ Unlatch Output 1 Alarm
- ◆ Unlatch Output 2 Alarm
- ◆ Unlatch Output 3 Alarm
- ◆ Start Batch
- ◆ Stop Batch
- ◆ Initiate Top-Off

Control Input configuration can be recorded in the chart on page 63.

1. Select the appropriate submenu. There is a separate submenu for each Control Input:
 - Submenu 65 – Control Input 1
 - Submenu 66 – Control Input 2
 - Submenu 67 – Control Input 3
 - Submenu 68 – Control Input B
2. Press the ^ key to scroll through the function options on the display.
3. Press the Reset key to select or deselect the function whose prompt is on the display. The indicator at the far right of the display changes to reflect the new status.

Submenu 69 – Reset Key Functions

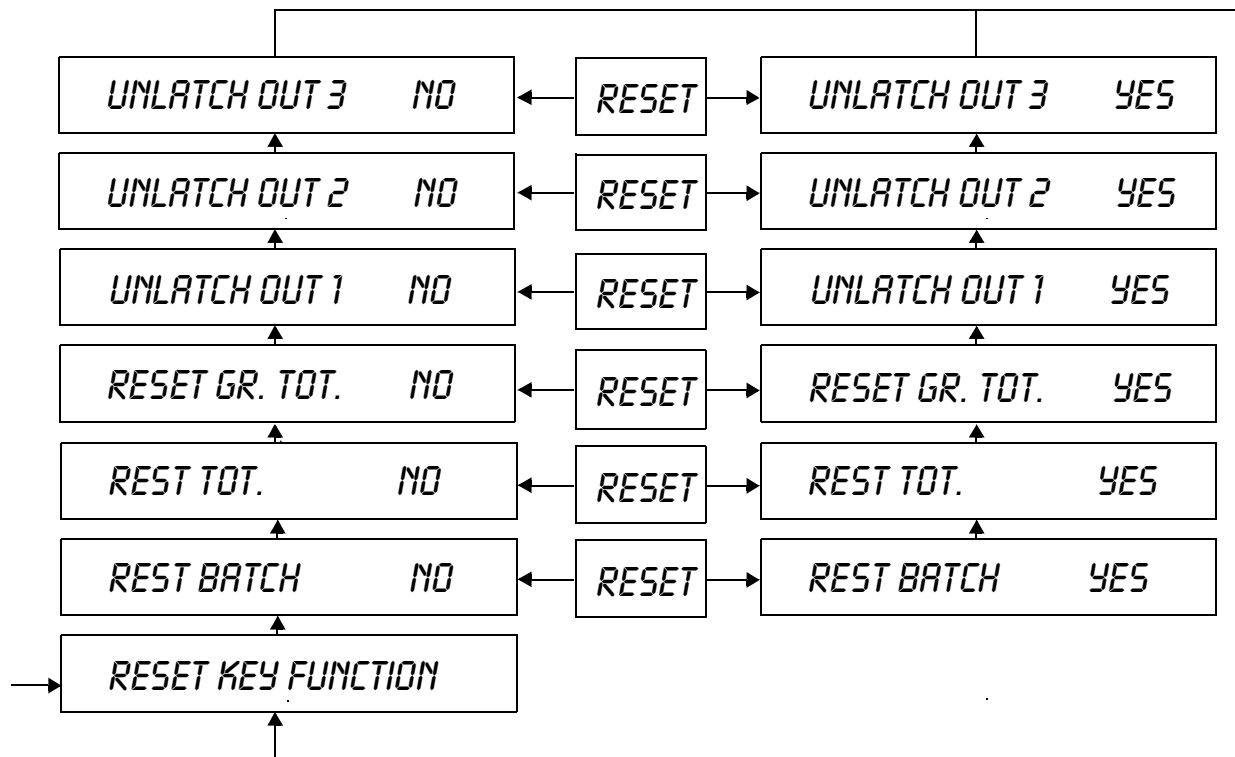

The Reset key can be configured to perform the same functions as the Control Inputs with the exception of Start Batch, Stop Batch, and Initiate Top-Off. Reset Key configuration can be recorded in the chart on page 63.

- ◆ See submenu 65 for instructions.

Row 7 Batch

Submenu 71 – Batching Operation

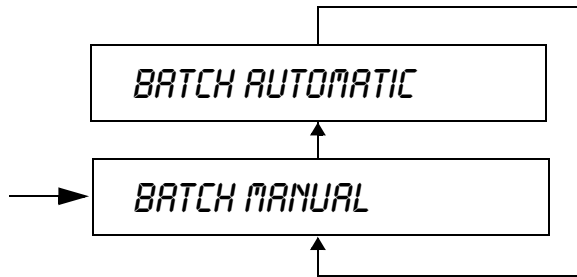

The 75LBA-....B provides automatic or manual batching operations. Press the ^ key to select automatic or manual. See Batching in the Introduction for a detailed description of each mode.

Submenu 72 – Top-Off Operation

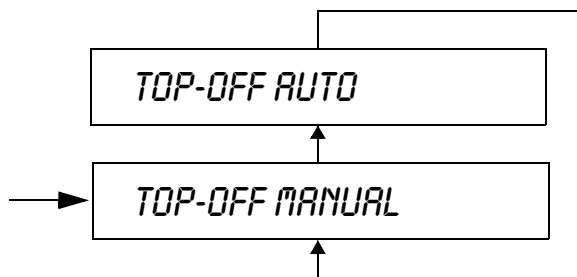

The Top-Off function has two modes of operation. See the Top-Off section under Batching in the Introduction for a detailed description of each mode.

- ◆ Use the ^ key to select manual or automatic.

Submenu 73 – Top-Off Set Point Value

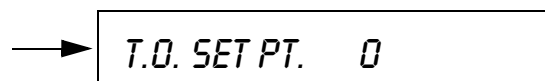

This block needs to be configured if the Top-Off was configured for automatic mode in submenu 72. Go to the next submenu if the manual mode was selected.

The value entered for the Top-Off set point represents the amount that is automatically added to the batch when the Top-Off key is pressed, or when a control input configured for this function is activated. The set point value must be in the same EGUs selected for the running totalizer. The minimum value that should be configured depends on the response characteristics of the loop and valve.

1. Press CLR to erase the old value from memory.
2. Key in a new value.
3. Press ENT to enter the new value into memory.

Submenu 74 – Reset Function for Batch Totalizer

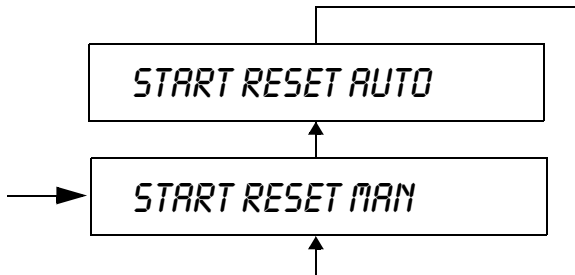

The batch totalizer can be configured for manual reset prior to pushing the start key to begin a new batch. Manually resetting the batch totalizer allows the user to interrupt and restart a batch operation. If desired, the batch totalizer can be configured to automatically reset whenever the start button is pushed in the Run mode.

- ◆ Use the ^ key to select manual reset or automatic reset for the batch totalizer.

Row 8 Other

Submenu 81 – Password



A password can be configured into the 75LBA-....B to provide security for access to the Program mode.

Enter a number from 1 to 6 digits in length into the password data field to make that number the password. That number must be entered from then on to access Program mode.



CAUTION: Take care not to lose the password; if you do, call Foxboro.

If you enter all zeros (000000) into the password data field, no password will be required to enter Program mode. The 75LBA -....B does not require the entry of a password to enter the Program mode as it comes from the factory.

To enter a new password:

1. Press CLR.
2. Enter the new password using the number keys.
3. Press enter to write new password and verify.

Submenu 82 – Baud Rate and Parity for Serial Communications



CAUTION: The serial communication available from the 75LBA-....B is not compatible with the serial communication available from the 760 series controllers.

The baud rate and parity for serial communications are set in this submenu.

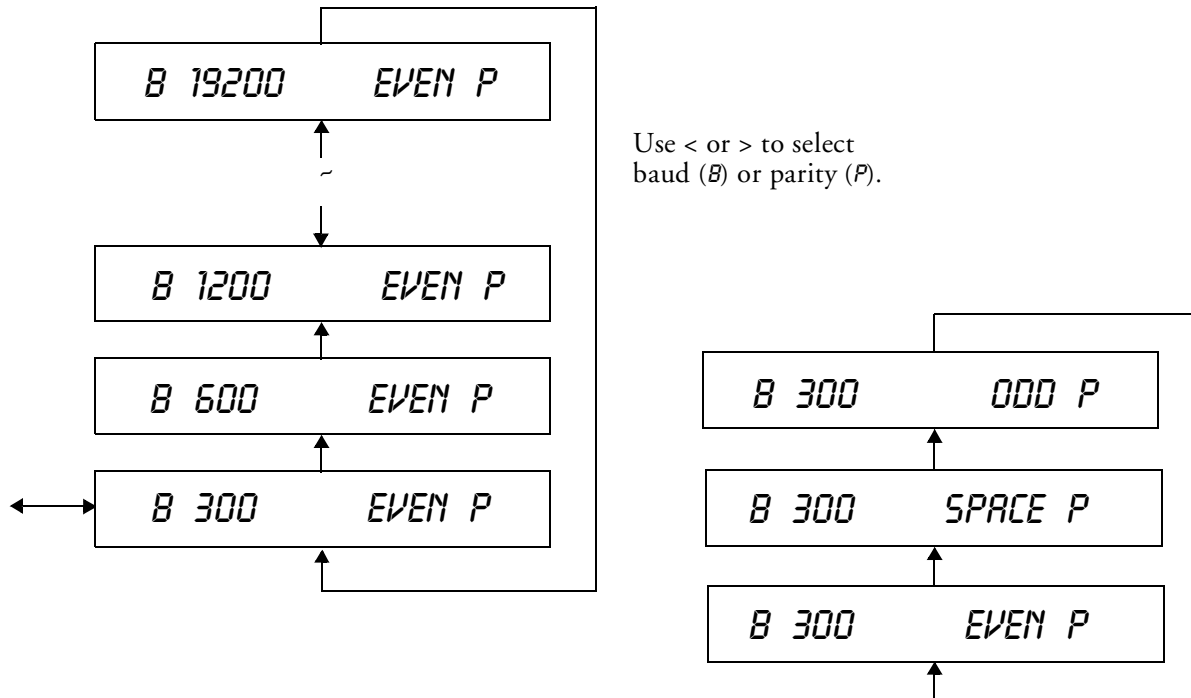

1. Use the < or > keys to select baud rate (B) or parity (P). The B or P characters blink when selected.
2. Use the ^ key to select a baud rate of 300, 600, 1200, 2400, 4800, 9600, or 19200 when the B is blinking.
3. Use the ^ key to select even, space, or odd parity when the P is blinking.

Submenu 83 – Unit ID Number and Response Delay Time for Serial Communications

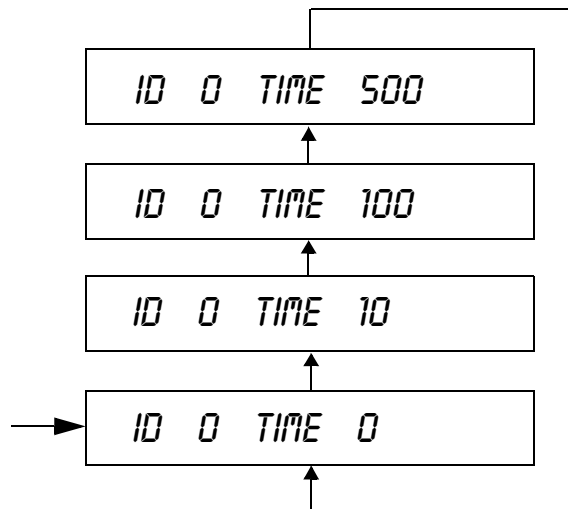

The unit identification number used for serial communications is set in this submenu. Each 75LBA-....B on the communication bus must have a unique identifying number, 1 through 255.

- ◆ Enter the unit ID by pushing CLR, keying in the ID number, and pressing ENT.

The length of time before the control response to a communications request can be set to accommodate various types of computer equipment. Delay times of 0, 10, 100 and 500 milliseconds can be selected.

- ◆ Press the ^ key to select one of the available delay times.

Submenu 84 – Instrument Tag Number

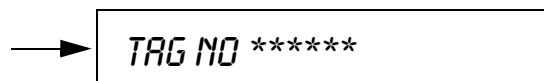

The instrument tag number can be configured for display in Run mode. The tag number can consist of up to six alphanumeric characters. Enter ******* or six spaces if no tag is required.

1. Use the < or > keys to cause a character to blink on the display.
2. Then press the ^ key to scroll through the alphanumeric characters. Available characters are A–Z, 0–9, “/”, “*” and space.
3. Repeat steps 1 and 2 for each of the six character positions.

Submenu 85 – Diagnostics

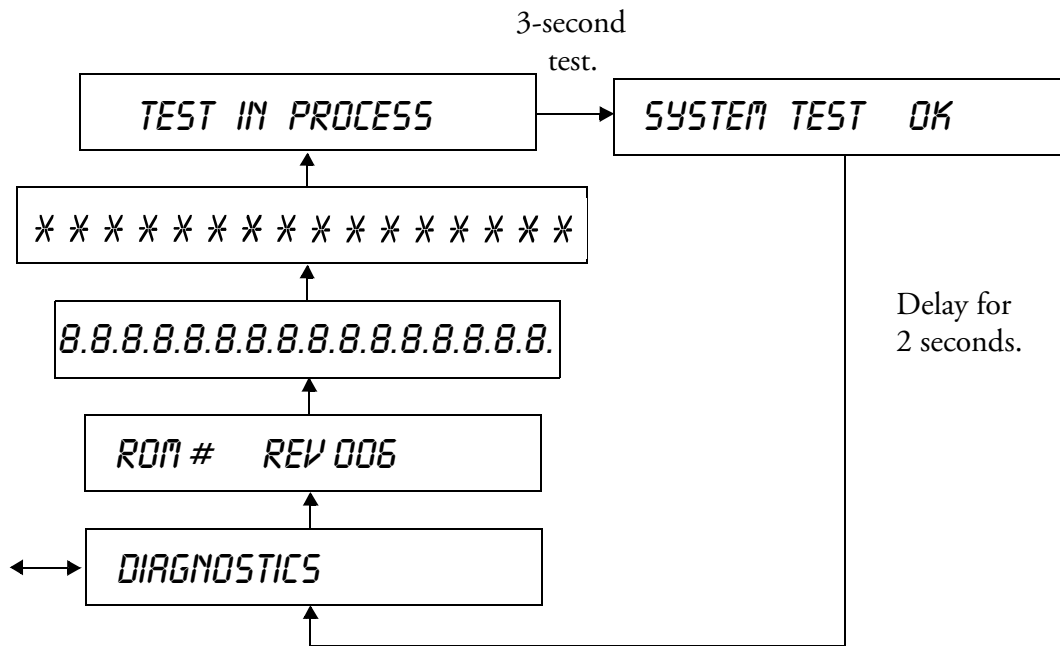

The diagnostics allow the user to test the 75LBA -...B 's display and internal memory.

1. Press the ^ key to obtain the ROM firmware version number.
2. Press the ^ key a second time for display test 1. Each of the display's 16 characters goes to *B* with the decimal points lit (*8.8.8.8.8.8.8.8.8.8.8.8.8.8.8.8.*).
3. Press the ^ key a third time for display test 2. Each of the display's characters changes to * (*******).
4. Press the ^ key a fourth time for the internal memory test.
 - ◆ The display reads *TEST IN PROCESS* for three seconds while the tests are being run.
 - ◆ The display reads *SYSTEM TEST OK* for two seconds, then goes back to *DIAGNOSTICS* if no memory errors were detected.

Whenever a power-up occurs, the unit performs memory tests of the microprocessor ROM and battery backed RAM. If any of these tests fail, it is considered to be a fatal error and the unit is nonfunctional.

A checksum test is then performed on stored program data in the memory. *REPROGRAM UNIT* appears if this test fails. A checksum test is then performed on the stored Run mode data. *RUN DATA ERROR* appears if this test fails. Pressing the Reset key will recover the unit from *REPROGRAM UNIT* and *RUN DATA ERROR* failures. The Program or Run mode data will need to be re-entered.

It is possible for electrical noise to cause a diagnostic failure. If a failure message occurs, recycle power to the unit. Diagnostics are automatically performed on any power-up. If a different error message appears, or no error message appears, it is highly probable that the failure was caused by electrical noise.

Configuration Reference Charts

Reset Key Function

- RESET BATCH
- RESET RUNNING TOTAL
- RESET GRAND TOTAL
- UNLATCH ALARM 1
- UNLATCH ALARM 2
- UNLATCH ALARM 3

Control Input Function

	INPUT 1	INPUT 2	INPUT 3	INPUT B
RESET BATCH	<input type="checkbox"/>	<input type="checkbox"/>	<input type="checkbox"/>	<input type="checkbox"/>
RESET RUNN TOT.	<input type="checkbox"/>	<input type="checkbox"/>	<input type="checkbox"/>	<input type="checkbox"/>
RESET GRAND TOT.	<input type="checkbox"/>	<input type="checkbox"/>	<input type="checkbox"/>	<input type="checkbox"/>
UNLATCH ALARM 1	<input type="checkbox"/>	<input type="checkbox"/>	<input type="checkbox"/>	<input type="checkbox"/>
UNLATCH ALARM 2	<input type="checkbox"/>	<input type="checkbox"/>	<input type="checkbox"/>	<input type="checkbox"/>
UNLATCH ALARM 3	<input type="checkbox"/>	<input type="checkbox"/>	<input type="checkbox"/>	<input type="checkbox"/>
START BATCH	<input type="checkbox"/>	<input type="checkbox"/>	<input type="checkbox"/>	<input type="checkbox"/>
STOP BATCH	<input type="checkbox"/>	<input type="checkbox"/>	<input type="checkbox"/>	<input type="checkbox"/>
TOP-OFF	<input type="checkbox"/>	<input type="checkbox"/>	<input type="checkbox"/>	<input type="checkbox"/>

Alarm Output Function

	ALARM 1	ALARM 2	ALARM 3
LABEL	-----	-----	-----
RUNNING TOTAL	<input type="checkbox"/>	<input type="checkbox"/>	<input type="checkbox"/>
BATH HI	<input type="checkbox"/>	<input type="checkbox"/>	<input type="checkbox"/>
BATCH LO	<input type="checkbox"/>	<input type="checkbox"/>	<input type="checkbox"/>
DENSITY HI	<input type="checkbox"/>	<input type="checkbox"/>	<input type="checkbox"/>
DENSITY LO	<input type="checkbox"/>	<input type="checkbox"/>	<input type="checkbox"/>
TEMP. HI	<input type="checkbox"/>	<input type="checkbox"/>	<input type="checkbox"/>
TEMP. LO	<input type="checkbox"/>	<input type="checkbox"/>	<input type="checkbox"/>
RATE HI	<input type="checkbox"/>	<input type="checkbox"/>	<input type="checkbox"/>
RATE LO	<input type="checkbox"/>	<input type="checkbox"/>	<input type="checkbox"/>
UNUSED	<input type="checkbox"/>	<input type="checkbox"/>	<input type="checkbox"/>

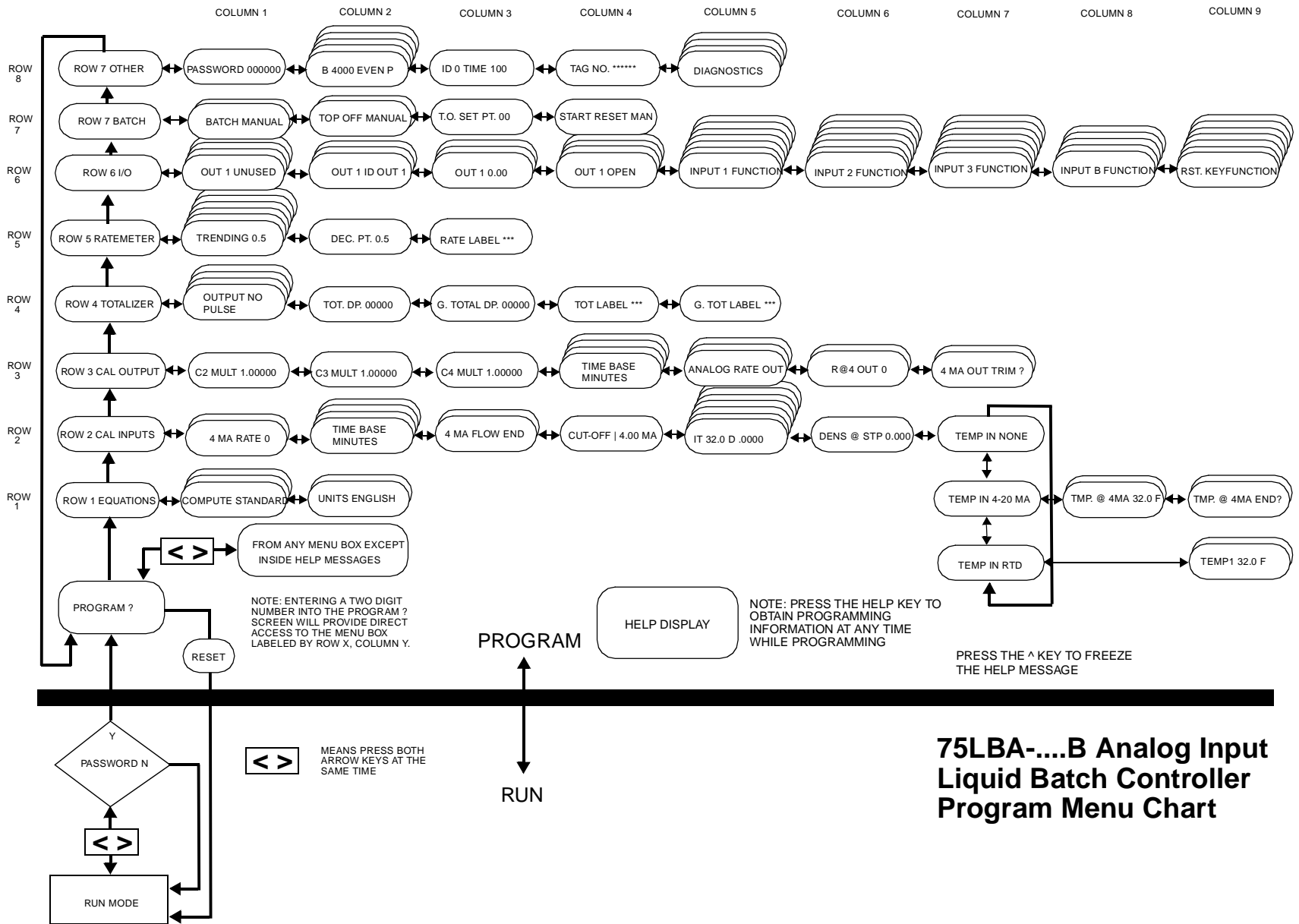

Help Message List

Main Help Message

PROGRAM BLOCKS ARRANGED IN 8 ROWS. FIRST BLOCK IN EACH ROW IS A TITLE BLOCK WITH ROW NUMBER. PRESS ^ KEY TO SELECT A ROW WHEN TITLE BLOCK IS DISPLAYED. PUSH < OR > TO SELECT A BLOCK WITHIN A ROW. PUSH HELP TO SEE HOW A BLOCK IS PROGRAMMED. PUSH ^ TO PAUSE AND RESUME MESSAGE SCROLL. RETURN TO PROGRAMMING BEFORE MESSAGE ENDS BY PUSHING ANY OTHER KEY. RETURN TO RUN MODE BY PUSHING < AND > KEYS AND THEN THE RESET KEY.

Submenu 11: Default Engineering Units (EGUs)

PUSH ^ TO SELECT DEFAULT ENG'G. UNITS FOR RATE/TOTAL. CHOOSE UNCOMP OR CHOOSE STANDARD OR MASS FOR COMPENSATION.

Submenu 12: Engineering Units

FOR COMPENSATION PUSH ^ TO SELECT ENGLISH OR METRIC DEFAULT ENGINEERING UNITS. ENGLISH UNITS ARE GALLONS - POUNDS- AND DEGREES FAHRENHEIT. METRIC DEFAULT UNITS ARE LITERS - KILOGRAMS - AND DEGREES CELSIUS. ENGLISH AND METRIC UNITS CANNOT BE MIXED. GO ON TO NEXT BLOCK FOR UNCOMP.

Submenu 21: Flow Input 4 to 20 mA Range

PUSH ^ TO SELECT 4 MA OR 20 MA. PUSH CLR - KEY FLOW INPUT LRV OR URV - PUSH ENTER. ENGR. UNITS MUST BE IN GALLONS OR LITERS PER UNIT TIME FOR COMPENSATION FEATURE.

Submenu 22: Input Rate Time Base

SELECT TIME BASE FOR RATE INPUT. PUSH ^ TO SELECT SECONDS -MINUTES - HOURS - OR DAYS.

Submenu 23: Flow Input Calibration

INPUT 4 MA SIGNAL AND PUSH ENTER. PUSH ^ TO SELECT 20 MA AND REPEAT PROCESS.

Submenu 24: Flow Input Current Cut-Off Point

ENTER VALUE IN MA FOR CUT OFF POINT. OUTPUT RATE WILL EQUAL ZERO WHEN INPUT SIGNAL FALLS BELOW CUT OFF VALUE. PUSH CLR - PUSH NUMBER KEYS - PUSH ENTER. RANGE FROM 4.00 TO 10.00.

Submenu 25: Temperature/Density Linearization Points

DENSITY CAN BE A SINGLE VALUE OR LINEARIZED OVER A RANGE OF TEMPERATURE. PUSH < OR > TO SELECT TEMPERATURE OR DENSITY. PUSH CLR - KEY NUMBER - PUSH ENTER. TEMPERATURE IS ENTERED AS DEGREES F OR DEGREES C. DENSITY IS ENTERED IN LB/GAL OR KG/LITER. PUSH ^ TO ENTER THE NEXT SET OF VALUES. UP TO 20 DATA PAIRS CAN BE ENTERED. IF NOT USING THE LINEARIZATION FEATURE - ENTER A SINGLE VALUE FOR DENSITY AND TEMP AND GO ON TO THE NEXT BLOCK. GO ON TO NEXT BLOCK FOR UNCOMP.

Submenu 26: Density at STP (Standard Temperature and Pressure)

FOR APPLICATIONS WHEN OUTPUT IS IN STANDARD GALLONS OR LITERS -ENTER DENSITY IN LB/GAL OR KG/LITER AT STANDARD CONDITIONS. PUSH CLR - ENTER NUMBER - PUSH ENTER.

Submenu 27: Temperature Input Selection

PUSH ^ TO SELECT TEMP. INPUT AS NONE, 4 to 20 MA, OR 4 WIRE PT RTD.

Submenu 28: Temperature Input 4 to 20 mA Range

PUSH ^ TO SELECT 4 OR 20 MA. PUSH CLR - KEY LRV OR URV FOR TEMP. IN DEGREES F OR DEGREES C - PUSH ENTER. USE +/- KEY TO ENTER NEGATIVE VALUE. RANGE FROM -9999.9 TO 9999.9.

Submenu 29: Analog Temperature Input Calibration

INPUT 4 MA SIGNAL FROM TRANSMITTER AND PUSH RESET. PUSH ^ TO SELECT 20 MA AND REPEAT PROCESS.

Submenu 29: Analog Temperature Input Calibration

CONNECT A KNOWN PRECISION RESISTANCE VALUE TO RTD INPUT. PUSH CLR - KEY IN VALUE OF TEMP. AT THAT RESISTANCE IN DEGREES F OR DEGREES C - PUSH ENTER. CONNECT SECOND KNOWN PRECISION RESISTANCE TO RTD INPUT. PUSH CLR - KEY IN VALUE OF TEMP. AT THAT RESISTANCE - PUSH ENTER. TWO TEMP. VALUES MUST DIFFER BY AT LEAST ONE DEGREE. DISPLAY WILL RETURN TO FIRST TEMP. TO INDICATE CALIBRATION IS COMPLETE.

Submenu 31: Running Total C2 Multiplier

C2 IS A CONVERSION FACTOR BETWEEN DESIRED ENG'G UNITS AND DEFAULT ENG'G UNITS FOR THE RUNNING TOTALIZER AND BATCH COUNTER. IF C2 EQUALS ONE THE DEFAULT UNITS WILL BE USED. SEE MI FOR COMMON VALUES FOR C2. PUSH CLR - KEY NUMBER WITH DEC. PT. - PUSH ENTER. RANGE FROM 0.00001 TO 999999.

Submenu 32: Grand Total C3 Multiplier

C3 IS A CONVERSION FACTOR BETWEEN DESIRED ENG'G UNITS AND DEFAULT ENG'G UNITS FOR THE GRAND TOTALIZER. IF C3 EQUALS ONE THE DEFAULT UNITS WILL BE USED. SEE MI FOR COMMON VALUES FOR C3. PUSH CLR -KEY NUMBER WITH DEC. PT. - PUSH ENTER. RANGE FROM 0.00001 TO 999999.

Submenu 33: Rate C4 Multiplier

C4 IS A CONVERSION FACTOR BETWEEN DESIRED ENG'G UNITS AND DEFAULT ENG'G UNITS FOR RATE DISPLAY/OUTPUT. IF C4 EQUALS ONE THE DEFAULT UNITS WILL BE USED. SEE MI FOR COMMON VALUES FOR C4. PUSH CLR -KEY NUMBER WITH DEC. PT. - PUSH ENTER. RANGE FROM 0.00001 TO 999999.

Submenu 34: Rate Time Base

SELECT TIME BASE FOR RATE DISPLAY/OUTPUT. PUSH ^ TO SELECT SECONDS - MINUTES - HOURS OR DAYS.

Submenu 35: Analog Output Parameter

PUSH ^ TO SELECT VARIABLE TO BE USED FOR ANALOG OUTPUT. CHOOSE RATE - TEMPERATURE OR DENSITY WHEN COMPENSATION IS USED. CHOOSE RATE FOR UNCOMP.

Submenu 36: Analog Output Calibration

PUSH ^ TO SELECT 4 OR 20 MA. PUSH CLR - KEY IN LRV OR URV - PUSH ENTER. TEMP. IN DEGREES F OR DEGREES C - DENSITY IN LB/GAL OR KG/LITER - RATE IN DESIRED ENGINEERING UNITS.

Submenu 37: Analog Output Trim

CONNECT ANALOG OUTPUT TO DVM PER MI. PUSH CLR AND THEN < OR > TO TRIM CURRENT TO 4 MA AND PUSH ENTER. PUSH ^ TO SELECT 20 MA AND REPEAT THE PROCESS.

Submenu 41: Running Totalizer Scaled Pulse Output

PUSH ^ TO ACTIVATE PULSE OUTPUT AND SELECT MAX FREQUENCY AND PULSE WIDTH. CHOOSE FAST - FST FOR 1500 HZ AND 0.125 MS - MEDIUM - MED FOR 200 HZ MAX AND 2 MS - SLOW - SLO FOR 10 HZ AND 50 MS.

Submenu 42: Running Total Decimal Point

PUSH 0 - 4 TO SELECT DEC. PT. FOR RUNNING TOTAL.

Submenu 43: Grand Total Decimal Point

PUSH 0 - 4 TO SELECT DEC. PT. FOR GRAND TOTAL.

Submenu 44: Running Total Label

PROGRAM UP TO 3 CHARACTERS FOR RUNNING TOTAL DISPLAY LABEL. PUSH < OR > TO SELECT POSITION - PUSH ^ TO SELECT CHARACTER.

Submenu 45: Grand Total Label

PROGRAM UP TO 3 CHARACTERS FOR GRAND TOTAL DISPLAY LABEL. PUSH < OR > TO SELECT POSITION - PUSH ^ TO SELECT CHARACTER.

Submenu 46: Batch Parameter Key Locks

PUSH 4 - 7 - 8 OR 9 TO SELECT PARAMETER KEY. PUSH ^ TO SELECT OPEN OR LOCKED. LOCKED DISABLES OPERATOR CHANGES FOR PARAMETER IN RUN MODE. VALUES FOR THESE PARAMETERS MUST BE ENTERED IN RUN MODE PRIOR TO LOCKING KEYS.

Submenu 51: Trending

PUSH ^ TO SELECT NEW TRENDING TIME FROM 0.5 TO 7.5 SECONDS. TREND TIME IS INTERVAL USED TO AVG. INPUT READINGS FOR RATE DISPLAY/OUTPUT.

Submenu 52: Ratemeter Decimal Point

PUSH 0 - 4 TO SELECT DEC. PT. FOR RATE.

Submenu 53: Rate Display Label

PROGRAM UP TO 3 CHARACTERS FOR RATE DISPLAY LABEL. PUSH < OR > TO SELECT POSITION - PUSH ^ TO SELECT CHARACTER.

Submenu 61: Alarm Output Configuration

PUSH 1 - 3 TO SELECT ALARM OUTPUT. PUSH ^ TO SELECT THE DESIRED CONDITION.

Submenu 62: Alarm Output Labels

PUSH 1 - 3 TO SELECT ALARM OUTPUT. PROGRAM UP TO 4 CHARACTERS FOR ALARM DISPLAY LABEL. PUSH < OR > TO SELECT POSITION - PUSH ^ TO SELECT CHARACTER.

Submenu 63: Alarm Output Timeout

PUSH 1 - 3 TO SELECT ALARM OUTPUT. ENTER TIME IN SECONDS ALARM OUTPUT STAYS LATCHED. OUTPUT REMAINS LATCHED UNTIL UNLATCHED BY OPERATOR IF 0 IS ENTERED. PUSH CLR - ENTER NUMBER - PUSH ENTER. RANGE FROM 0 TO 99.99 SECONDS. PUSH ^ TO SELECT FOLLOWS. OUTPUT AUTOMATICALLY UNLATCHES WHEN CONDITIONS RETURN TO NORMAL IF FOLLOWS IS CHOSEN.

Submenu 64: Run Mode Alarm Point Key Lock

PUSH 1 - 3 TO SELECT ALARM OUTPUT. PUSH ^ TO SELECT OPEN OR LOCKED. LOCKED DISABLES OPERATOR CHANGES FOR ALARM VALUES IN RUN MODE. VALUES FOR ALARMS MUST BE ENTERED IN RUN MODE PRIOR TO LOCKING KEYS.

Submenu 65: Control Inputs 1

PUSH ^ TO SELECT FUNCTION OPTIONS FOR EXTERNAL SWITCH INPUT 1. PUSH RESET TO ANSWER YES OR NO FOR EACH FUNCTION OPTION DISPLAYED.

Submenu 66: Control Inputs 2

PUSH ^ TO SELECT FUNCTION OPTIONS FOR EXTERNAL SWITCH INPUT 2. PUSH RESET TO ANSWER YES OR NO FOR EACH FUNCTION OPTION DISPLAYED.

Submenu 67: Control Inputs 3

PUSH ^ TO SELECT FUNCTION OPTIONS FOR EXTERNAL SWITCH INPUT 3. PUSH RESET TO ANSWER YES OR NO FOR EACH FUNCTION OPTION DISPLAYED.

Submenu 68: Control Inputs B

PUSH ^ TO SELECT FUNCTION OPTIONS FOR EXTERNAL SWITCH INPUT B. PUSH RESET TO ANSWER YES OR NO FOR EACH FUNCTION OPTION DISPLAYED.

Submenu 69: Reset Key Functions

PUSH ^ TO SELECT FUNCTION OPTIONS FOR RESET KEY. PUSH RESET TO ANSWER YES OR NO FOR EACH FUNCTION OPTION DISPLAYED.

Submenu 71: Batching Operation

PUSH ^ TO SELECT AUTOMATIC OR MANUAL BATCH OPERATION.

Submenu 72: Top-Off Operation

PUSH ^ TO SELECT AUTOMATIC OR MANUAL TOP OFF OPERATION.

Submenu 73: Top-Off Set Point Value

FOR APPLICATIONS WHEN TOP OFF IS IN THE AUTOMATIC MODE. THIS IS THE AMOUNT THAT WILL AUTOMATICALLY BE ADDED WHEN THE TOP OFF FUNCTION IS INITIATED. PUSH CLR - ENTER NUMBER - PUSH ENTER.

Submenu 74: Reset Function for Batch Totalizer

PUSH ^ TO SELECT AUTOMATIC OR MANUAL RESET FOR BATCH TOTALIZER.

Submenu 81: Password

PUSH CLR - ENTER NUMBER - PUSH ENTER. RANGE FROM 0 TO 999999. ENTER 0 FOR NO PASSWORD.

Submenu 82: Baud Rate and Parity for Serial Communications

PUSH < OR > TO SELECT BAUD RATE OR PARITY. PUSH ^ TO SELECT OPTIONS.

Submenu 83: Unit ID Number and Response Delay Time for Serial Communications

PUSH CLR - ENTER NUMBER - PUSH ENTER TO INPUT VALUE FOR UNIT IDENTITY. RANGE FROM 0 TO 255. EACH UNIT ON THE COMMUNICATION LINK MUST HAVE A UNIQUE NUMBER. PUSH ^ TO SELECT THE MINIMUM COMMUNICATION RESPONSE TIME.

Submenu 84: Instrument Tag Number

PROGRAM UP TO 6 CHARACTERS FOR THE TAG NUMBER. PUSH < OR > TO SELECT POSITIONS - PUSH ^ TO SELECT CHARACTERS.

Submenu 85: Diagnostics

PUSH ^ 4 TIMES TO TEST DISPLAY AND START THE DIAGNOSTIC ROUTINE.

4. Normal Operation

Key Functions

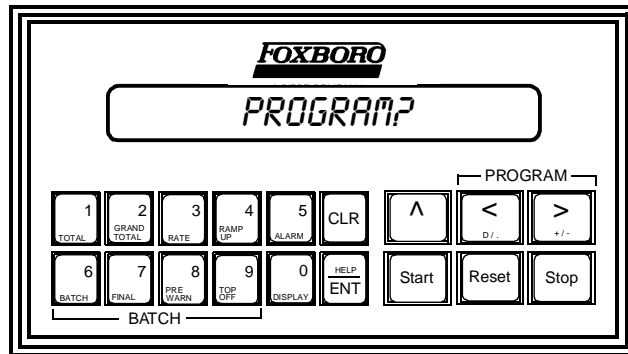

The various keys on the front panel of the 75LBA and their associated functions in Run mode are:

<div style="border: 1px solid black; padding: 2px; width: 40px; height: 40px; display: flex; flex-direction: column; justify-content: center; align-items: center;"> 0 DISPLAY </div>	to	<div style="border: 1px solid black; padding: 2px; width: 40px; height: 40px; display: flex; flex-direction: column; justify-content: center; align-items: center;"> 9 TOP OFF </div>	Use to enter new values for Lo/Hi alarm points, final batch set point, pre-warn value and ramp-up value.
<div style="border: 1px solid black; padding: 2px; width: 40px; height: 40px; display: flex; flex-direction: column; justify-content: center; align-items: center;"> 1 TOTAL </div>			Press to display running total with EGU label. <div style="border: 1px solid black; padding: 5px; margin-top: 5px; display: flex; justify-content: space-between;"> TOT 0 GAL </div>
<div style="border: 1px solid black; padding: 2px; width: 40px; height: 40px; display: flex; flex-direction: column; justify-content: center; align-items: center;"> 2 GRAND TOTAL </div>			Press to display grand total with EGU label. <div style="border: 1px solid black; padding: 5px; margin-top: 5px; display: flex; justify-content: space-between;"> GT 0 GPM </div>
<div style="border: 1px solid black; padding: 2px; width: 40px; height: 40px; display: flex; flex-direction: column; justify-content: center; align-items: center;"> 3 RATE </div>			Press to display rate with EGU label. <div style="border: 1px solid black; padding: 5px; margin-top: 5px; display: flex; justify-content: space-between;"> RATE 0 GAL </div>
<div style="border: 1px solid black; padding: 2px; width: 40px; height: 40px; display: flex; flex-direction: column; justify-content: center; align-items: center;"> 6 BATCH </div>			Press to display batch total. <div style="border: 1px solid black; padding: 5px; margin-top: 5px; display: flex; justify-content: space-between;"> BATCH 0 GAL </div>
<div style="border: 1px solid black; padding: 2px; width: 40px; height: 40px; display: flex; flex-direction: column; justify-content: center; align-items: center;"> 7 FINAL </div>			Press to display or change final batch set point. <div style="border: 1px solid black; padding: 5px; margin-top: 5px; display: flex; justify-content: space-between;"> FINAL 0 GAL </div>
<div style="border: 1px solid black; padding: 2px; width: 40px; height: 40px; display: flex; flex-direction: column; justify-content: center; align-items: center;"> 4 RAMP UP </div>			Press to display or change ramp-up value (enter as percentage of final batch set point). <div style="border: 1px solid black; padding: 5px; margin-top: 5px; display: flex; justify-content: space-between;"> RAMP UP 0% </div>



Press to display or change pre-warn value (enter as percentage of final batch set point).



Press to display or change alarm point values. Press the ^ key to select alarm output 1, 2, or 3 after the alarm key is pressed.

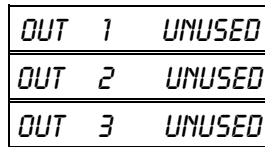

Press to initiate the Top-Off function. In manual mode K2 relay remains on as long as the key remains pressed. In automatic mode, a preset amount is added to the batch each time the key is pressed. Top-Off amount is entered in the Program mode.



Press to clear old parameter values from memory prior to entering new values.



Press to display programmable default parameters. Default display will be shown after any power-up or after exiting the Program mode.

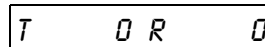

Press to enter parameter values into memory after new values have been keyed in.

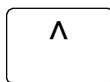

Press to scroll values for secondary parameters currently in memory, or scroll options for default display after the < key has been pressed for 2 seconds, or press after the alarm key has been pressed to select alarm output 1, 2 or 3.

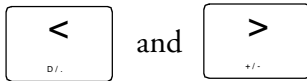

Press simultaneously to enter Program mode.

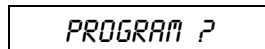

Press to initiate/restart batching operation.



Press to stop batch processing.

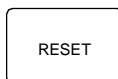

Perform configured functions on total, rate, and/or batch operations.

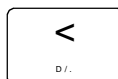

Press to Display labels for default displays or press and hold for 2 seconds to configure default display.

Accessing Run Mode from Program Mode

During normal operations, the unit is in Run mode. To access Run mode from Program mode, press the < and > keys at the same time. This returns the unit to the Program mode entry/exit display.

PROGRAM?

Pressing the Reset key at this time causes the unit to go to Run mode.

NOTE: If the unit has not been fully configured yet, the display blinks CONFIGURE UNIT. The unit is not preconfigured at the factory and must be configured prior to startup. Once the unit is configured, the CONFIGURE UNIT prompt no longer appears.

Default Display

The default display is shown on power-up, on exiting the Program mode, or on demand by pressing the display key in Run mode. The default display can be configured to be any one of twelve different parameters. These are summarized below. Some default display options contain two parameters shown simultaneously.

Default Parameter	Display
Batch and Rate	B 0 R 0
Batch and Final	B 0 F 0.00
Rate and Density	R 0 0 0
Temp. and Dens.	T 0 0 0.00
Total	TOT 0 GAL
Grand Total	GT 0 GAL
Batch	BATCH 0 GAL
Rate	RATE 0 GPM
Temperature	TEMP 0

Default Parameter	Display
Density	DENSITY 0.00
Analog Out	ANALOG OUT .00
Total and Rate	T 0 R 0

To configure the default display:

1. Press and hold the < key for approximately 2 seconds until the display blinks momentarily.
2. Then press the ^ key to select the desired parameter.
3. Pressing any number key causes the selected parameter to be shown in the default display.

NOTE: The 75LBA -...B is in Run mode while the default display is being configured. All functions are still enabled.

Secondary Parameters

Pressing the ^ key while in Run mode allows the user to scroll through the values of the following parameters whose values are stored in Program mode: temperature, density, C₂ multiplier, C₃ multiplier, C₄ multiplier, input rate timebase, output rate timebase, standard density, analog output percent, top-off setpoint, instrument tag number, and software ROM number. The user exits display of secondary parameters by pressing any other display keys. Normal Run mode operations continue while secondary parameters are being displayed.

Alarm Point Values

To change alarm point values in Run mode, follow these steps:

1. Press key 5 to view alarm point values.
2. Select alarm output 1, 2, or 3 by using the ^ key. These outputs will be identified on the display using the labels configured in submenu 62. Besides the output identification label, the current value for the alarm point will be displayed.
3. Press CLR to erase an old value from memory.
4. Key in a new value and press ENT to enter this value into memory.

Key 5 can be independently locked for output 1, 2, or 3 in submenu 64. If key 5 is configured to be locked for a specific alarm output, the alarm point value cannot be changed in Run mode. The user must first enter Program mode, giving the password if one is set, unlock the key for that output, and then return to Run mode to change the value.

Alarm points for rate, running total, and batch total must be entered in the same EGUs specified in submenus 12, 31, 32, 33, and 34. Alarm points for temperature must be entered in degrees Fahrenheit (English) or Celsius (Metric). Alarm points for density must be entered in pounds per gallon (English) or kilograms per liter (Metric). Only one set point can be entered for running total.

Alarm points for rate, temperature, and density can be configured to latch, time out, or follow (see submenu 63). Alarm outputs for batch and running totals can be configured to latch or time out.

Three NPN transistors are provided for alarm outputs. These transistors are de-energized when the 75LBA-....B is in Program mode. When output alarms are actuated, the display will blink alternately between the selected parameter data and the ****** ACTIVE** message.

Batching

In the manual mode of operation (see submenu 71), a batch is initiated by pressing the Start key, or activating a control input configured for that function. This energizes the K2 relay. The relay remains energized until the Stop key is pressed, or a control input configured for that function is activated. The batch totalizer must be reset by pressing the Reset key, or by activating a control input configured for that function.

You can configure the batch totalizer to automatically reset every time the start command is given (see submenu 74). The automatic reset feature should not be configured if the user wants the capability to interrupt and restart a batch before completion. There are no final batch set point, ramp-up, or pre-warn values associated with manual batching operation. Values entered for these parameters will not affect manual batching operations.

In the automatic batching mode, both the K1 and K2 relays are used. The user must enter values for the final batch set point, ramp-up and pre-warn values prior to starting a batch. Final set point is entered in the same EGUs as displayed for the batch and running total. Ramp-up and pre-warn are entered as percentages of the final batch set point.

The K2 relay is energized when a batch start command is given by pressing the Start key or activating a control input. The K1 relay is energized when the batch total reaches a value equivalent to the ramp-up value. The K1 relay remains energized until the batch total reaches a value equivalent to the pre-warn value.

The K2 relay is de-energized when the batch total reaches the final set point value. The batch total can be configured to automatically reset whenever a start command is given, or it can be configured for manual reset. Do not configure the automatic reset feature if the user desires the capability to interrupt and restart a batch before completion.

The K1 and K2 relays can be de-energized at any time by giving a stop command. The batch operation will be re-initiated at the point of interruption when a start command is given.

The user may desire to increment, or top off, a batch after a batch cycle has been completed. This can be accomplished by using the top-off feature. The top-off feature can be configured for manual or automatic mode (see submenu 72).

In the manual mode, the K2 relay is energized when the Top-off key is pressed, or a control input configured for that function is activated. The relay remains energized as long as the key remains pressed, or the input activated.

In the automatic mode, the K2 relay is energized just long enough to add a configured amount (submenu 73) to the batch each time the top-off command is given.

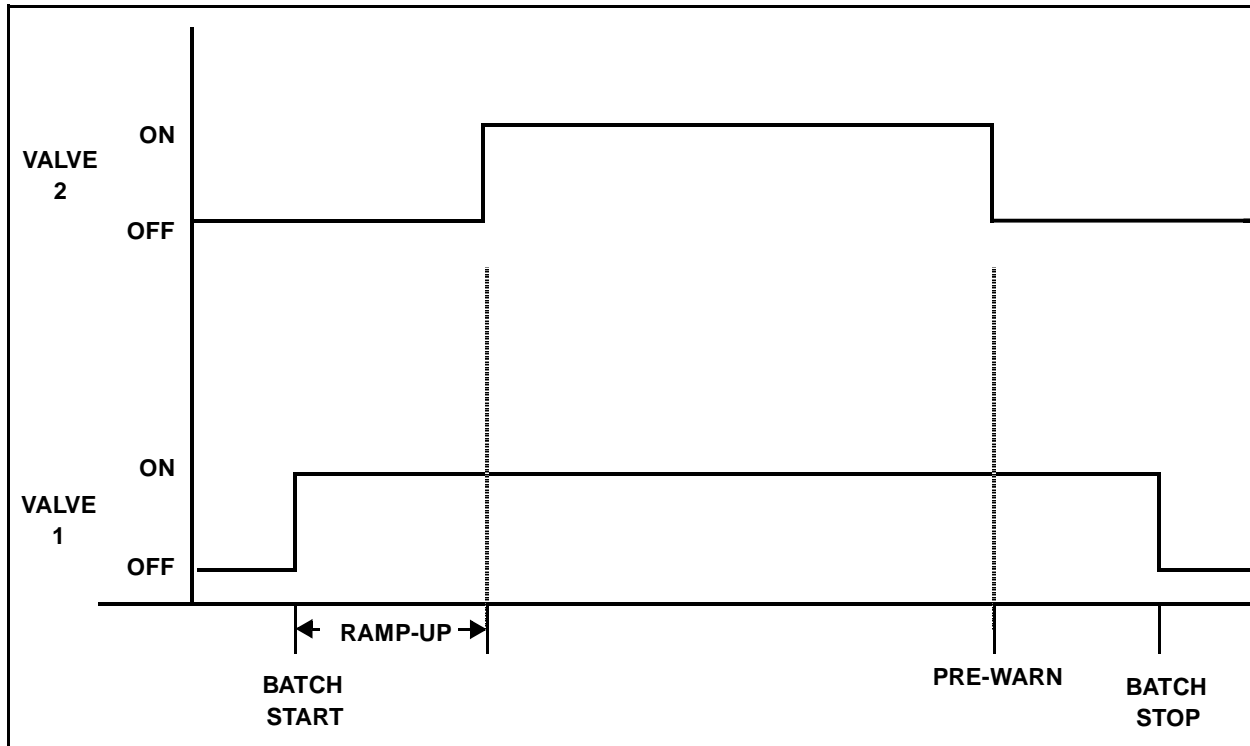

Figure 25. Batching Operation Schematic Diagram

Reset Key

The Reset key can be configured to reset the batch totalizer, reset the running totalizer, reset the grand totalizer, and unlatch alarm outputs 1, 2 and 3 (see submenu 68). The reset key can perform none, all, or any combination of these functions.

Analog Flow Input

The 75LBA-...B can accept a 4 to 20 mA input linearly proportional to flow rate. The 75LBA-....B has a programmable input current cut-off point between 4 mA and 10 mA.

The input current can correspond to any desired flow rate EGUs, with a time base of seconds, minutes, hours, or days, when the compensation feature is not being used.

The input current must correspond to flow rate EGUs of gallons or liters, with a time base of seconds, minutes, hours, or days, when the compensation feature is being used.

Control Inputs

There are four external control inputs that can be configured to reset the batch total, reset the running total, reset the grand total, unlatch alarm outputs 1, 2, or 3, start batching, stop batching, and initiate top-off. Each control input can be configured to do none, all, or any combination of the above functions (see submenus 65, 66, 67, 68). Control inputs are disabled in Program mode. Activated control inputs will override keypad functions. For example, if a control input configured to stop batching is activated, the 75LBA-....B will not initiate a new batch if the Start key is pressed until the control input is first de-activated.

Temperature Input

The channel for temperature input can be used in two different ways: 4 to 20 mA current loop or RTD. The RTD must be a 4-wire platinum RTD (European Alpha 3850 curve). The input temperature range is -196 to +454 degrees Celsius (-320 to +850 degrees Fahrenheit).

A 20 point density vs. temperature curve can be configured into the memory of the 75LBA-....B. Density will be constantly calculated from this curve, based on the current value for the temperature input, and used to display total/rate in standard or mass EGUs.

Ratemeter Operation

The rate input current is defined in submenus 21 and 22. The rate input current cut-off point is defined in submenu 24. Input rate is calculated from the formula:

$$\text{Input Rate} = (\text{Input current} - 4 \text{ mA})(\text{Slope}) + 4 \text{ mA Rate}$$

where:

$$\text{Slope} = \frac{20 \text{ mA Rate} - 4 \text{ mA Rate}}{16 \text{ mA}}$$

Rate will be displayed in the EGUs and time base defined by submenus 21, 33, and 34 when the compensation feature is not being used. Rate will be displayed in the EGUs and time base defined by submenus 11, 12, 33 and 34 when the compensation feature is being used.

Displayed rate will be zero whenever the flow input current has a value between 4 mA and the configured cut-off current value.

The following example illustrates 75LBA-....B ratemeter operation given the following configured values:

- Submenu 11 - Uncomp
- Submenu 21 - 4 mA = 0 gpm
20 mA = 500 gpm
- Submenu 22 - Minutes
- Submenu 24 - 6.00 mA
- Submenu 33 - $C_4 = 1.00$
- Submenu 34 - Minutes

Input Current	Displayed Rate	Output Current
3.94 mA	0 gpm	3.8 mA
3.95	0	4
3.99	0	4
4.00	0	4
5.99	0	4
6.00	62.50	6.00
9.00	156.25	9.00
19.50	484.37	19.50
20.00	500.00	20.00
20.30	500.00	20.00
20.31	500.00	21.00

Analog Output

The 75LBA-....B provides a 4 to 20 mA analog output that can be configured to represent displayed flow rate, input temperature, or calculated density. The 4 mA and 20 mA points are programmable.

The 4 mA point must correspond to a variable value which is less than the variable value corresponding to the 20 mA point. Configuring the 4 mA point greater than or equal to the 20 mA point disables the analog output by driving it to 3.8 mA.

The analog output goes to 4 mA on power-up and while the unit is in Program mode.

When configured to be proportional to displayed rate, the analog output functions as described below:

- 3.8 mA if input current < 3.95 mA
- 4.0 mA if input current is between 3.95 and 4.00 mA
- 4.0 mA if input current is between 4.00 mA and cut-off point
- 4.0-20.0 mA if input current is between cut-off and 20.00 mA
- 20.0 mA if input current is between 20.0 and 20.3 mA
- 21.0 mA if input current is > 20.3 mA

When configured to be proportional to input temperature or calculated density, the analog output functions as described below:

- 4.0-20.0 mA if lower range value \leq variable \leq upper range value

Totalizer Pulse Output

An NPN transistor output is provided to drive an external totalizer. Totalizer pulse output is coincident with the least significant whole digit of the running total display. The totalizer pulse off time increases when no counting is being done. The totalizer counts are buffered via a 255-count buffer which allows for momentary over ranges. The output pulse width can be configured for fast (125 usec), medium (2 msec), or slow (50 msec). The totalizer pulse output is inactive whenever the 75LBA-....B is in Program mode.

Run Mode Display Messages

Message	Meaning
<i>RUN DATA ERROR</i>	Run mode data corrupted
<i>INV</i>	Invalid key
<i>TEMP. INPUT ERROR</i>	Temperature input configured but inactive
<i>INVALID PASSWORD</i>	Password entry incorrect
<i>FLOW OVERRUN</i>	Calculated flow for period too large
<i>PULSE OVERFLOW</i>	Scaled pulse output lagging
<i>RATE OVERFLOW</i>	Calculated flow larger than configured display resolution
<i>D POINT CONFLICT</i>	Same temperature configured with more than one value of density
<i>NO DENSITY PROG.</i>	Density is required for standard or mass flow compensation but is not configured
<i>**** ACTIVE</i>	Alarm output active
<i>ANA OUTPUT ERROR</i>	4 mA output > 20 mA output
<i>CONFIGURE UNIT</i>	This message appears on first power-up as a warning to configure unit before start-up
<i>REPROGRAM UNIT</i>	Program mode data corrupted
<i>ROM FAILURE</i>	Fatal diagnostic test error messages
<i>INT RAM FAILURE</i>	
<i>EXT RAM FAILURE</i>	

5. Fault Isolation

The table below lists possible failure indications and recommended actions.

Table 1. Possible Failure Indications and Recommended Actions

Failure Indication	Recommended Action
LED display does not light up.	Check power connector and power wiring.
Unit fails power-up diagnostics.	Verify that power input voltage is within acceptable range. Cycle power. If the unit fails again, replace it.
Unit displays zero rate or no total change.	Make sure the unit is in Run mode. Check signal wiring and flowmeter.
Unit displays wrong values or operates incorrectly.	Enter Program mode and verify that all settings are correct. Run diagnostics.
Unit fails diagnostics.	Replace the unit.
Unit passes diagnostics but runs improperly.	Check for sources of electrical noise on signal and power wiring. Inspect the unit for physical damage. Make sure connector pins are not corroded. If the unit is installed in a harsh environment, check the enclosure for leaks. Make sure the enclosure operating temperature is within acceptable range.

NOTE: If a unit fails diagnostics, it may refuse to operate from then on, even if power is cycled. The unit must be replaced when this happens.

Replacing the Unit



WARNING: Turn off power to the unit before replacing it. The power connector has exposed metal parts that can present a shock hazard.

To replace the unit, follow these steps:

1. Unpack the replacement unit. Do not discard the shipping material.
2. Open the enclosure.
3. Turn off power to the defective unit.
4. Examine the data plate on the defective unit and the replacement unit. Verify that they are the same models.
5. Disconnect the power and signal connectors from the rear of the defective unit.
6. Unscrew the four screws that clamp the defective unit to the front panel.
7. Unsnap the two mounting brackets from the defective unit's case.

8. Slide out the defective unit.
9. Place the O-ring gasket on the replacement unit and carefully seat it in the groove around the front bezel.
10. Examine the two plastic mounting clips. A screw symbol molded into each clip indicates the proper orientation of the clip. The screw head should point toward the rear of the instrument. Also note the threaded holes on each side of the clip.
11. Insert the replacement unit into the panel opening.
12. Snap the two plastic mounting clips onto the replacement unit.
13. Thread the four mounting screws through the threaded holes on the mounting clips and finger tighten against the panel.
14. Carefully tighten the screws until the front bezel just touches the front panel.



CAUTION: Do not overtighten the mounting screws. Damage to the instrument can result.

15. Pack the defective unit in the replacement unit's shipping package.

This unit contains no serviceable parts. A defective unit must be returned to the local Foxboro office for replacement. Contact your local Foxboro office for shipping instructions.

6. Serial Communication

Purpose

The 75LBA-....B is equipped with an RS-485 serial communications port for the purpose of allowing a computer to:

1. Issue control commands such as reset.
2. Query Run mode data such as count, rate, alarm points, etc.
3. Load alarm points.
4. Query and configure all configure mode submenus except: 23, 29, 37, 81, 82, 83, and 85.



CAUTION: Use of the serial communication feature requires expertise in computer programming and data communications. Development of systems using this feature should be carried out by properly trained personnel and should follow sound industrial practices for programming, documentation and testing.

NOTE: The serial communication available with the 75LBA-....B is not compatible with serial communication available from the 760 series controllers.

Serial Communication Description

The serial format follows the Opto 22 Optomux protocol. This consists of a start character (>), a two-character unit ID number, a three-character command, data for the command (if applicable), a two-character checksum and a termination character.

Each character is ten bits. The first bit is the start bit, followed by seven data bits (ASCII code), followed by the parity bit and the tenth bit is the stop bit. If the unit is configured to space parity, the unit ignores the received parity and transmits space parity. The unit ID number and checksum are in ASCII hexadecimal and have a range of 00 to FF. The checksum is the two least significant hexadecimal digits of the sum of the ASCII values of the unit ID number, the command and the data. All hexadecimal characters A through F must be in upper case. All leading zeroes in data fields must be sent. Decimal points within the data field are indicated by an ASCII comma. Commas within data fields sent to the unit are ignored. The termination character may be an ASCII carriage return or an ASCII decimal point.

Responses by the control consist of three possibilities:

1. A (acknowledge)
2. Ad..cc (acknowledge with data, d..., and checksum of the data, cc)
3. Nee (not acknowledge with a two-digit error code, ee)

Example: Command sent >01RST10BB.

where

> is the start character

01 is the unit ID number

RST is the three character command (reset)

10 is reset flow totalizer

BB is the two least significant digits of the hexadecimal checksum

. is the termination character

Error Codes

- 01 Invalid Command
- 02 Communication Checksum Error
- 03 Buffer Overrun Error
- 05 Data Format Error
- 08 Parity or Framing Error
- 10 In Run Mode, Command not Allowed
- 12 In Program Mode, Command not Allowed
- 13 Mode Already Active, Command not Allowed
- 21 Data Out of Range

Classifications

All serial commands fall into the following classifications:

1. Control Commands
2. Query Run Data
3. Load Run Data
4. Query Program Data
5. Load Program Data

The 75LBA-....B has two modes of operation: Run mode and Program mode. The unit will respond to specific commands only if the command is valid for the mode of operation the unit is in when the command is received. Command validity and all specific commands are described in detail in the following sections.

Control Commands

There are three control commands: Enter Program Mode, Exit Program Mode and Reset. Enter Program Mode and Exit Program Mode are used to change the units mode of operation. The 75LBA-....B goes into Run mode when it powers up. Reset does not change the unit's mode of operation, but performs a reset and/or unlatch function while leaving the unit in Run mode. The Reset command is suffixed by two digits (ab) which allow for secondary functions to occur along with the Reset function.

All following commands are preceded by the start character (>) and unit ID number and succeeded by the two-character checksum and carriage return.

Table 2. Control Commands

Command	Response	Description
RSTab	A	Reset command where "ab" determines functions to perform:
Digit a	= 1 = 2 = 3 = 4 = 5 = 6 = 7	Reset flow totalizer Reset flow grand totalizer Reset both flow totalizers Reset batch counter Reset batch counter and flow totalizer Reset batch counter and flow grand totalizer Reset batch counter and both flow totalizers
Digit b	= 1 = 2 = 3 = 4 = 5 = 6 = 7	Unlatch output 1 Unlatch output 2 Unlatch outputs 1 and 2 Unlatch output 3 Unlatch outputs 1 and 3 Unlatch outputs 2 and 3 Unlatch outputs 1, 2, and 3
EPM	A	Enter Program mode
PEX	A	Exit Program mode

Query Data Commands

The following data query commands are supported in the 75LBA-....B.

Table 3. Query Data Commands

Command	Response	Description
QOS	AOSabc	Query Output Status where: a = Current mode = R – Run mode = P – Program mode b = Output 1 status = A – Output On = N – Output Off c = Output 2 status = A – Output On = N – Output Off d = Output 3 status = A – Output On = N – Output Off
QRT	ARTaaaaaa	Query Flow Rate where: aaaaaa = Rate
QBC	ABCaaaaaa	Query Batch Counter where: aaaaaa = Batch Count
QAT	AATaaaaaaaa	Query Total where: aaaaaaaa= Totalizer Count
QAG	AAGaaaaaaaaaa	Query Grand Total where: aaaaaaaaaa= Totalizer Count
QSA	ASAsaaaaaa	Query Output 1 Alarm Point where: aaaaa = Output 1 Alarm point s = Sign (space or -)
QSB	ASBsaaaaaa	Query Output 2 Alarm Point where: aaaaa = Output 2 Alarm Point s = Sign (space or -)
QSC	ASCsaaaaaa	Query Output 3 Alarm Point where: aaaaaa= Output 2 Alarm Point s = Sign (space or -)
NOTE: The totalizer alarm point includes eight digits. The rate or density alarm points include six digits. The temperature alarm points include five digits plus a sign.		
QFS	AFSaaaaaa	Query Final Setpoint where: aaaaaa = Final Setpoint

Table 3. Query Data Commands (Continued)

Command	Response	Description
QRU	ARUaa	Query Ramp-Up Percent where: aa = Ramp-Up Percent of Final
QPW	APWaa	Query Pre-Warn Percent where: aa = Pre-Warn Percent of Final
QTP	ATPsaaaaa	Query Current Temperature where: aaaaa = Current Temperature s = sign (space or -)
QDN	ADNaaaaaa	Query Current Density where: aaaaaa = Current Density
QMD	Aa...	Query Menu Data where: a... = Data specified in current menu
QAP	Aab c... ab c	Query All Program Data where: a = Program Menu Row b = Program Menu Column c = Applicable Data

Load Data Commands

The following data load commands are supported in the 75LBA-....B.

Table 4. Load Data Commands

Command	Response	Description
LSAsaaaaaa	A	Load Alarm Point 1 where: aaaaaa = Alarm Point 1 s = Sign (space or -)
LSBsaaaaaa	A	Load Alarm Point 2 where: aaaaaa = Alarm Point 2 s = Sign (space or -)
LSCsaaaaaa	A	Load Alarm Point 3 where: aaaaaa = Alarm Point 3 s = Sign (space or -)
NOTE: When loading totalizer alarm point, eight digits are required. Six digits are required for rate and density alarm points. Five digits plus a sign are required for temperature alarm points.		
LFSaaaaaa	A	Load Final Setpoint where: aaaaaa = Final Setpoint
LRUaa	A	Load Ramp-Up Percent where: aa = Pre-Warn Percent of Total
LPWaa	A	Load Pre-Warn Percent where: aa = Pre-Warn Percent of Total
LCMabc	A	Load Communication Menu where abc determine the information that will be sent by the control when it is issued a QMD command. The following table illustrates the bit assignments for the available data. Setting the appropriate bits will cause that data to be sent.
Digit a (0-F)	Bit 0 Bit 1 Bit 2 Bit 3	Status Flow Rate Total Grand Total
Digit b (0-F)	Bit 0 Bit 1 Bit 2 Bit 3	Batch Count Alarm Point for Output 1 Alarm Point for Output 2 Alarm Point for Output 3
Digit c (0-7)	Bit 0 Bit 1 Bit 2 Bit 3	Final Setpoint Ramp-Up Percent Pre-Warn Percent Current Temperature
Digit d (0-1)	Bit 0	Current Density

Load Program Data Commands

The following Program mode commands are supported by the 75LBA-....B. Decimal points are not required by the command except for those configuration blocks that allow for a floating decimal point. All other program blocks will insert the decimal point in the correct location.

Table 5. Load Program Data Commands

Command	Response	Description
L11 a	A	Load Display Parameter where: a = 0 – Actual Flow a = 1 – Standardized Flow a = 2 – Mass Flow
L12 a	A	Load Units of Measure where: a = 0 – English a = 1 – Metric
L21 aaaaaa bbbbbb	A	Load Flow Analog Input where: aaaaaa = 4 mA Rate bbbbbb = 20 mA Rate
L22 a	A	Load Flow Input Time base where: a = 0 – seconds a = 1 – minutes a = 2 – hours a = 3 – days
L24 aaaa	A	Load Flow Input Cut-Off Current where: aaaa = Current (xx.xx)
L25 aa sbbbbbb cccccc	A	Load Density Curve Point where: aa = Point (1-20) s = Sign bbbbbb = Temperature ccccc = Density
L26 aaaaaa	A	Load Standard Density where: aaaaaa = Standard Density
L27 a	A	Load Temperature Input Select where: a = 0 – None a = 1 – 4-20 mA a = 2 – RTD
L28 aaaaa bbbbbb	A	Load Temperature Analog Input where: aaaaa = 4 mA point bbbbbb = 20 mA point
NOTE: Include sign to indicate positive or negative temperature value.		

Table 5. Load Program Data Commands (Continued)

Command	Response	Description
L31 aaaaaa	A	Load C ₂ Multiplier where: aaaaaa = C ₂ Multiplier (0.000001 - 999999) (D.P. valid)
L32 aaaaaa	A	Load C ₃ Multiplier where: aaaaaa = C ₃ Multiplier (0.000001 - 999999) (D.P. valid)
L33 aaaaaa	A	Load C ₄ Multiplier where: aaaaaa = C ₄ Multiplier (0.000001 - 999999) (D.P. valid)
L a	A	Load Time base where: a = 0 – Seconds = 1 – Minutes = 3 – Hours = 4 – Days
L35 a	A	Load Analog Output Selec where: a = 1 – Flow Rate = 2 – Temperature = 3 – Density
L36 aaaaaa bbbbbb	A	Load Analog Output Values where: aaaaaa = 4 mA point bbbbbb = 20 mA point Note: Rate and Density values are six digits, temperature values are five digits plus a sign indicator.
L41 a	A	Load Pulse Output Select where: a = 0 – No pulse output = 1 – Fast = 2 – Medium = 3 – Slow
L42 a	A	Load Totalizer D.P. Location where: a = 0 – No D.P. = 1 – XXXXXXXX.X = 2 – XXXXXXXX.XX = 3 – XXXXXX.XXX = 4 – XXXX.XXXX

Table 5. Load Program Data Commands (Continued)

Command	Response	Description
L43 a	A	Load Grand Total D.P. Location where: a = 0 – No D.P. = 1 – XXXXXXXX.X = 2 – XXXXXXXX.XX = 3 – XXXXX.XXX = 4 – XXXX.XXXX
L44 aaa	A	Load Totalizer Display Header where: aaa = Tot. Display Header
L45 aaa	A	Load Grand Total Display Header where aaaa = G. Tot. Display Header
L46 a	A	Load Key Locks where: a = 0 – No keys locked Bit 0 – Lock Final Bit 1 – Lock Pre-Warn Bit 2 – Lock Top-Off Bit 3 – Lock Ramp-Up
L51 aa	A	Load Ratemeter Trending where aa = Trending time 0.5 – 7.5 in 0.5 resolution
L52 a	A	Load Ratemeter D.P. Location where: a = 0 – No D.P. = 1 – XXXXX.X = 2 – XXXX.XX = 3 – XXX.XXX = 4 – XX.XXXX
L53 aaa	A	Load Rate Display Header where: aaa = Rate Disp. Header

Table 5. Load Program Data Commands (Continued)

Command	Response	Description
L61 abc	A	Load Output Alarm Functions where: a = Output 1 Alarm Function b = Output 2 Alarm Function c = Output 3 Alarm Function where: 0 = Unused 1 = Rate Lo Alarm 2 = Rate Hi Alarm 3 = Temp. Lo Alarm 4 = Temp. Hi Alarm 5 = Dens. Lo Alarm 6 = Dens. Hi Alarm 7 = Batch Lo Alarm 8 = Batch Hi Alarm 9 = Totalizer Alarm
L62 aaaa bbbb cccc	A	Load Output Alarm Identifier where aaaa = Output 1 ID bbbb = Output 2 ID cccc = Output 3 ID
L63 a b c	A	Load Output Characteristics where: a = Char. of Output 1 b = Char. of Output 2 c = Char. of Output 3 where: 0 = Output Follows xxxx = Output Time
NOTE: A space must follow each piece of data.		
L64 a	A	Load Output Alarm Locks where: a determines which alarms are locked. Setting the appropriate bit will lock the alarm.
Digit a (0-7)	Bit 0 Bit 1 Bit 3	Lock Output 1 Alarm Lock Output 2 Alarm Lock Output 3 Alarm

Table 5. Load Program Data Commands (Continued)

Command	Response	Description
L65 abc L66 abc L67 abc L68 abc	A A A A	Load Control Input 1 Functions Load Control Input 2 Functions Load Control Input 3 Functions Load Control Input B Functions where: ab determine the functions of Control input. Setting the appropriate bit will enable that function.
Digit a (0-F)	Bit 0 Bit 1 bit 2 Bit 3	Reset Batch Counter Reset Totalizer Reset Grand Totalizer Unlatch Output 1
Digit b (0-F)	Bit 0 bit 1 Bit 2 Bit 3	Unlatch Output 2 Unlatch Output 3 Start Batch Stop Batch
Digit c (0-1)	Bit 0	Top-Off
L69 ab	A	Load Reset Key Functions where: ab determine the functions of the Reset key. Setting the appropriate bit will enable that function.
Digit a (0-F)	Bit 0 Bit 1 Bit 2 Bit 3	Reset Batch Counter Reset Total Reset Grand Total Unlatch Output 1
Digit b (0-3)	Bit 0 Bit 1	Unlatch Output 2 Unlatch Output 3
L71 a	A	Load Batch Operation where: a = 0 – Manual = 1 – Automatic
L72 a	A	Load Top-Off Operation where: a = 0 – Manual = 1 – Automatic
L73 aaaaaa	A	Load Top-Off Setpoint where: aaaaaa = Top-Off Setpoint

Table 5. Load Program Data Commands (Continued)

Command	Response	Description
L74 a	A	Load Batch Counter Reset Function where: a = 0 – Manual = 1 – Automatic
L84 aaaaaa	A	Load Tag Identifier where: aaaaaa = Tag ID

Appendix A. Conversion Factors

Conversion factors for some common units of volume and mass are given below.



CAUTION: Conversion factors are shown to the maximum accuracy that can be entered into the unit. Use of factors marked * results in some loss of accuracy (~0.1%). Use of factors marked ** results in significant loss of accuracy (~1%).

Table 6. Conversion Factors (Volume)

To Obtain → Multiply Below by	Common Values of C ₂ (Volume)					
	U.S. Gallon (liquid)	Cubic Foot	Barrel (oil)	Cubic Meter	Liter	Imperial Gallon
U.S. Gallon	1.00000	0.13368	0.02381	0.00379*	3.78541	0.83267
Cubic Foot	7.48052	1.00000	0.17811	0.02832	28.3168	6.22884
Barrel (Oil)	42.0000	5.61458	1.00000	0.15899	158.987	34.9723
Cubic Meter	264.172	35.3147	6.28981	1.00000	1000.00	219.969
Liter	0.26417	.035310	0.00629	0.00100	1.00000	0.21997
Imperial Gallon	1.20095	0.16054	0.02859	0.00455*	4.54609	1.00000

Table 7. Conversion Factors (Mass)

To Obtain → Multiply Below by	Common Values of C ₂ (Mass)					
	Pounds	Kilogram	Gallon H ₂ O (32°F, in vacuum)	Ton (Short)	Tonne (Metric)	Ton (Long)
Pounds	1.00000	0.45359	0.11985	0.00050	0.00045**	0.00045**
Kilogram	2.20462	1.00000	0.26422	0.00110*	0.00100	0.00098**
Gallon H ₂ O (32°F)	8.34360	3.78460	1.00000	0.00417*	0.00378*	0.00372*
Ton (Short)	2000.00	907.185	239.704	1.00000	0.90718	0.89286
Tonne (Metric)	2204.62	1000.00	264.228	1.10231	1.00000	0.98421
Ton (Long)	2240.00	1016.05	268.469	1.12000	1.01605	1.00000

Index

115 V wiring 19
230 V wiring 20

A

ac power wiring 19
Accessing program mode 33
Accessing run mode from program mode 73
Alarm output function 64
Alarm point values 74
Analog flow input 76
Analog output 78
Automatic batching operation 5

B

Batching 75
Batching operation 4

C

Calculated rate 3
Configuration reference charts 63
Configuration/Program mode 33
Configuring the reset key 75
Control commands 85
Control input function 63
Control inputs 77
Conversion factors 95

D

dc power wiring 21
Default display 73
Default display shown on power-up 73
Density calculations 5
Density-versus-temperature curve 6

E

Equations used to calculate total 1
Error codes 84

F

Fault isolation 81

G

Grand total engineering units 3

H

Hi/Lo alarm outputs 2, 4

I

Installation 11

Installing field-mounted instrument 14

Installing instrument in enclosure 14

Installing panel-mounted instrument 12

Instrument identification 11

K

Key functions 34, 71

L

LBA

definition 1

Load data commands 88

Load program data commands 89

M

Manual batching operation 4

Messages 79

Mounting enclosure on a pipe 15

Mounting enclosure to a surface 14

N

Normal operation 71

P

Preparing enclosure for field wiring 14

Q

Query data commands 86

R

- Rate analog output 4
- Rate label 4
- Ratemeter operation 3, 77
- Replacing the unit 81
- Reset key 75
- Row 1 equations 35
- Row 2 Cal. Inputs 36
- Row 3 Cal. Output 42
- Row 4 Totalizer 48
- Row 5 Ratemeter 51
- Row 6 I/O 52
- Row 7 Batch 58
- Row 8 Other 59
- Run mode
 - accessing from Program mode 73
- Run mode display messages 79
- Running total engineering units 3

S

- Secondary parameters 74
- Serial communication 83
- Signal wiring 22
- Specifications 6
 - Agency approval 9
 - Ambient temperature limits 7
 - Approximate mass 9
 - Field-mounted enclosure 8
 - Inputs 7
 - Outputs 7
 - Panel-mounted enclosure 8
 - Power 6
 - Ratemeter 6
 - Relative humidity limits 7
 - Totalizers 6
 - Wiring connections 8
- Submenu 11 – Default Engineering Units (EGUs) 35
- Submenu 12 – Engineering Units 36
- Submenu 22 – Input Rate Time Base 37
- Submenu 23 – Flow Input Calibration 38
- Submenu 24 – Flow Input Current Cut-Off Point 38
- Submenu 25 – Temperature/Density Linearization Points 39
- Submenu 26 – Density at STP 39
- Submenu 27 – Temperature Input Selection 40
- Submenu 28 – Temperature Input 4 - 20 mA Range 40
- Submenu 29 – Analog Temperature Input Calibration 41

Submenu 29 – RTD Temperature Input Calibration	41
Submenu 31 – Running Total C2 Multiplier	42
Submenu 32 – Grand Total C3 Multiplier	43
Submenu 34 – Rate Time Base	44
Submenu 35 – Analog Output Parameter	44
Submenu 37 – Analog Output Calibration	45
Submenu 37 – Analog Output Trim	45
Submenu 41 – Running Totalizer Scaled Pulse Output	48
Submenu 42 – Running Total Decimal Point	48
Submenu 43 – Grand Total Decimal Point	49
Submenu 44 – Running Total Label	49
Submenu 45 – Grand Total Label	49
Submenu 46 – Batch Parameter Key Locks	50
Submenu 51 – Trending	51
Submenu 52 – Ratemeter Decimal Point	51
Submenu 53 – Rate Display Label	51
Submenu 61 – Alarm Output Configuration	52
Submenu 62 – Alarm Output Labels	53
Submenu 63 – Alarm Output Timeout	54
Submenu 64 – Run Mode Alarm Point Key Lock	55
Submenu 69 – Reset Key Functions	57
Submenu 71 – Batching Operation	58
Submenu 72 – Top-Off Operation	58
Submenu 73 – Top-Off Set Point Value	58
Submenu 74 – Reset Function for Batch Totalizer	59
Submenu 81 – Password	59
Submenu 82 – Baud Rate and Parity for Serial Communications	60
Submenu 83 – Unit ID Number and Response Delay Time for Serial Communications	61
Submenu 84 – Instrument Tag Number	61
Submenu 85 – Diagnostics	62
Submenus 65, 66, 67, 68 – Control Inputs 1, 2, 3, B Functions	56

T

TB1 – ac Power Input	16
TB2 – Digital Outputs, 24 V dc Power Input and Output	16
TB3 – Valve Relays	16
TB4 – Analog Output, Flowmeter and RTD Inputs	17
TB5 – Control Inputs and RS485 Communications	18
Temperature input	77
Top-off function	5
Total labels	3
Totalizer pulse output	79
Totalizers	
operation	1
Transistor output T4	2
Trending	3

U

Unpacking and inspection 11

W

Wiring

115 V 19

230 V 20

dc power 21

I/O and power terminal descriptions 15

Wiring ac power 19

ISSUE DATES

NOV 1993
AUG 1995
MAR 1998

Vertical lines to right of text or illustrations indicate areas changed at last issue date.

The Foxboro Company

33 Commercial Street
Foxboro
Massachusetts 02035-2099

Telephone: 1-888-FOXBORO
(1-888-369-2676)

Facsimile: (508) 549-4999

A Siebe Group Company

Foxboro and I/A Series are registered trademarks of The Foxboro Company.
Siebe is a registered trademark of Siebe, plc.
Noryl is a trademark of The General Electric Company.
Optomux is a trademark of Opto 22 Corp.

Copyright 1993-1998 by The Foxboro Company
All rights reserved